



Symbol	Botanical Name	Common Name	WUCOLS REGION 4	Size	Qty
	<i>Chilopsis linearis</i> 'Bubba'	Desert Willow	Low	36" Box Std.	81
	<i>Cercis s. Forest Pansy</i>	Forest Pansy Redbud	Low	24" Box Std.	17
	<i>Geijera parviflora</i>	Australian Willow	Mod	15 Gallon Std.	135
	<i>Logosteaemia hybrid</i> 'Tucacora'	Hybrid Cape Myrtle	Low	24" Box Std.	16
	<i>Logosteaemia l. 'Natchez'</i>	Natchez Cape Myrtle	Mod	24" Box Std.	25
	<i>Olea europaea</i> 'Wilson'	Fruitless Olive	Low	48" Box Multi.	14
	<i>Pinus edulis</i>	Mandell Pine	Low	24" Box Std.	96
	<i>Platanus x acerifolia</i>	London Plane Tree	Mod	24" Box Std.	36
	<i>Platanus racemosa</i>	California Sycamore	Low	48" Box Multi.	3
	<i>Pyrus californiana</i> 'Chanticleer'	Calvery Pear	Mod	24" Box Std.	79
	<i>Quercus l. Fastigiata</i>	English Oak	Mod	36" Box Std.	59
	<i>Tistaria canterla</i>	Brisbane Box	Mod	24" Box Std.	76
	<i>Ulmus parvifolia</i> 'Duke'	Duke Evergreen Chinese Elm	Low	15 Gallon Std.	55
	<i>Zelkova serata</i> 'City Sprite'	City Sprite Zelkova	Mod	36" Box Std.	113

Symbol	Botanical Name	Common Name	WUCOLS REGION 4
	<i>Agave d. 'Variegata'</i>	Variegated Smooth Agave	Low
	<i>Aloe Blue Elf</i>	Blue Elf Aloe	Low
	<i>Arizocarpus foetidus</i>	Kangaroo Paw	Low
	<i>Baccharis p. 'Twin Peaks'</i>	Coyote Bush	Low
	<i>Conocarpus glaucescens</i>	Mexican Bird of Paradise	Low
	<i>Callisander v. 'Little John'</i>	Dwarf Bottlebrush	Low
	<i>Citrus aurantium</i>	Orchid Root Rose	Low
	<i>Dryopteris</i>	Desert Spoon	Low
	<i>Eremophila g. 'Mingener Gold'</i>	Gold Emu Bush	Low
	<i>Furcraea l. 'Medicinal'</i>	Mauritius Hemp	Low
	<i>Grevillea lanigera</i> 'Coastal Gem'	Coastal Gem Grevillea	Low
	<i>Muhlenbergia capillaris</i>	Pink Muhly Grass	Low
	<i>Lantana New Gold</i>	New Gold Lantana	Low
	<i>Leucophyllum f. 'Compacta'</i>	Texas Ranger	Low
	<i>Lomandra 'Breezy'</i>	Dwarf Mat Rush	Low
	<i>Lomandra 'Platinum Beauty'</i>	Platinum Beauty Lomandra	Low
	<i>Leucophyllum f. 'Texas Ranger'</i>	Texas Ranger	Low
	<i>Penstemon h. 'Margatta BOP'</i>	Margatta BOP Blue Bedder	Low
	<i>Rosa Flower Carpet</i>	Groundcover Rose	Mod
	<i>Romarinus o. 'Huntington Carpet'</i>	Creeper Rosemary	Low
	<i>Ruscus equisetiformis</i>	Coral Fountain	Mod
	<i>Salvia greggii</i> 'Flame'	Furnans Red Autumn Sage	Low
	<i>Salvia leucantha</i>	Mexican Bush Sage	Low
	<i>Westringia f. 'Mund'</i>	Mund Coast Rosemary	Low
	<i>Zauschneria californica</i>	California Fuchsia	Low

Symbol	Botanical Name	Common Name	WUCOLS REGION 4
	<i>Agave 'Blue Glow'</i>	Blue Glow Agave	Low
	<i>Aloe Blue Elf</i>	Blue Elf Aloe	Low
	<i>Bougainvillea 'Raspberry Ice'</i>	Bougainvillea	Low
	<i>Bubbia frutescens</i> 'Holtmatt'	Staked Bubbia	Low
	<i>Lavandula 'Meeita'</i>	Meeita English Lavender	Low

Symbol	Botanical Name	Common Name	WUCOLS REGION 4
	<i>Rhamnus californica</i> 'Eve Case'	Dwarf Coffeeberry	Low
	<i>Westringia 'Blue Gem'</i>	Blue Gem Coast Rosemary	Low

- NOTES:
- PLANT MATERIAL NOT LISTED MAY BE USED, SUBJECT TO APPROVAL BY THE CITY.
  - ALL LANDSCAPE PLANS AND INSTALLATIONS SHALL ADHERE TO CITY DESIGN GUIDELINES, CODES AND REGULATIONS.
  - ALL LANDSCAPE AREAS SHALL RECEIVE AN AUTOMATIC IRRIGATION SYSTEM.
  - ALL LANDSCAPE INSTALLATIONS SHALL BE PERMANENTLY MAINTAINED.

OFFSITE PLANTING NOTE:  
REFER TO MASTER DEVELOPER LANDSCAPE PLANS FOR OFFSITE IMPROVEMENTS

Category	Value
SHIPPING CENTER	1,077
PARKING LOT STALLS	180 (1 TREE PER 6 STALLS)
PARKING LOT TREES REQUIRED	300
PARKING LOT TREES PROVIDED	117 (39% REQUIRED)
PARKING LOT TREES 36" BOX	
TOTAL SITE AREA	970,806 S.F.
TOTAL LANDSCAPE AREA REQUIRED	97,080 (10% OF TOTAL SITE AREA)
TOTAL LANDSCAPE AREA PROVIDED	106,895 S.F. (11% OF TOTAL SITE AREA)
COMMERCIAL RETAIL	822
PARKING LOT STALLS	137 (1 TREE PER 6 STALLS)
PARKING LOT TREES REQUIRED	227
PARKING LOT TREES PROVIDED	82 (36% REQUIRED)
PARKING LOT TREES 36" BOX	
TOTAL SITE AREA	893,404 S.F.
TOTAL LANDSCAPE AREA REQUIRED	89,340 (10% OF TOTAL SITE AREA)
TOTAL LANDSCAPE AREA PROVIDED	144,511 S.F. (16% OF TOTAL SITE AREA)



CONCEPTUAL LANDSCAPE PLAN  
HARVEST LANDING RETAIL CENTER & BUSINESS PARK  
S.W.C. OF PERRIS BLVD AND ORANGE AVE  
PERRIS, CA 92571



SCALE: 1"=80'  
CDPC PROJECT NO. 23073  
OCTOBER 30, 2025



conceptual design + planning company  
1475 Serrano Drive, Suite 200  
Costa Mesa, CA 92626  
T: 949.269.0270  
www.cdpc.com



L-1  
1 OF 5



- RAISED SEATWALL AT STOREFRONT, TYP.
- SMALL FLOWERING STOREFRONT ACCENT TREE CERCIS C. FOREST PANSY
- PARKING SHADE TREE ZELKOVA 'CITY SPRITE'
- PARKING SHADE TREE PYRUS CHANTICLEER
- CURVED SEATWALLS AT OPEN SPACE
- SHRUB/ GROUNDCOVER AREA AT MEDIAN, MAINTAIN VISIBILITY PEDESTRIAN SAFETY
- PEDESTRIAN PASEO WITH TRELLIS
- VERTICAL EVERGREEN HEDGE TO SCREEN TRANSFORMER
- TURF AREA
- 36" HT HEDGE AT INTERFACE BETWEEN TURF AREA AND VEHICULAR DROP OFF ZONE
- ENHANCED PAVING
- FLOWERING ACCENT TREES AT PLAZA ENTRY/ DROP OFF AREA
- CURVED BENCH SEATING AT PLAZA SPECIMEN TREES
- DINING PATIO

- ENHANCED VEHICULAR PAVING
- ENHANCED LANDSCAPING AT PROJECT ENTRIES
- PROJECT SIGNAGE, REFER TO SIGN PROGRAM
- TRANSFORMER
- PLANTED BUFFER BETWEEN PATIO AND WALKWAYS
- ORANGE AVENUE
- WATER FEATURE WITH THEMATIC SCULPTURAL ELEMENT AS A FOCAL POINT
- PLANTERS POTS TO PROVIDE BUFFER AT PATIO RAILING
- SHADE STRUCTURE PER ARCHITECT
- CONCRETE SIDEWALK
- ENHANCED PAVING PRECAST CONCRETE PAVERS
- CORNER PLAZA SPECIMEN TREE PLATANUS RACEMOSA
- THEMATIC PEDESTRIAN BRIDGE AT DRY CREEK
- CENTRAL PLANTER ISLAND WITH SEATING AND EVERGREEN PLAZA SHADE TREES
- CANTILEVERED SHADE STRUCTURE W/ SEATWALL
- PROJECT ID SIGNAGE
- LOW SPREADING GROUNDCOVER
- SMALL FLOWERING PATIO TREES TO PROVIDE SHADE AT BENCH SEATING AREA
- DRY CREEK FEATURE



CONCEPT MATERIAL AND FURNISHINGS NOTE:  
REFER TO ARCHITECTS PLANS FOR ADDITIONAL INFORMATION AND SPECIFICATIONS.

ENTRY DRIVE ENLARGEMENT



OFFSITE PLANTING NOTE:  
REFER TO MASTER DEVELOPER LANDSCAPE PLANS FOR OFFSITE IMPROVEMENTS

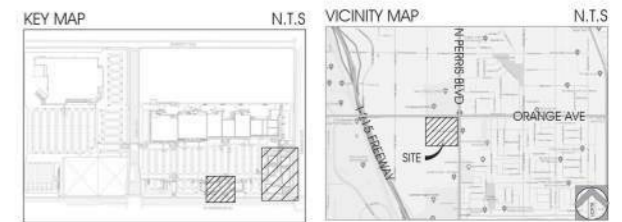

CONCEPTUAL LANDSCAPE PLAN  
HARVEST LANDING RETAIL CENTER & BUSINESS PARK  
S.W.C. OF PERRIS BLVD AND ORANGE AVE  
PERRIS, CA 92571



SCALE: 1"=20'  
CDPC PROJECT NO. 23072  
OCTOBER 30, 2025

conceptual design + planning company  
1475 Soerens Drive, Suite 200  
Costa Mesa, CA 92626  
T: 949.269.2870  
www.cdpc.com





OPEN SPACE ENLARGEMENT

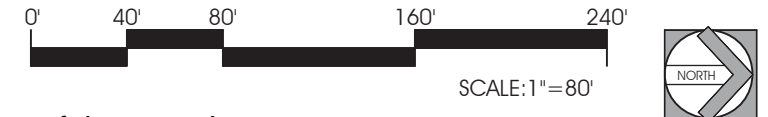

Walking Trail around perimeter of the amenity area:  
3300 LF = .625 miles

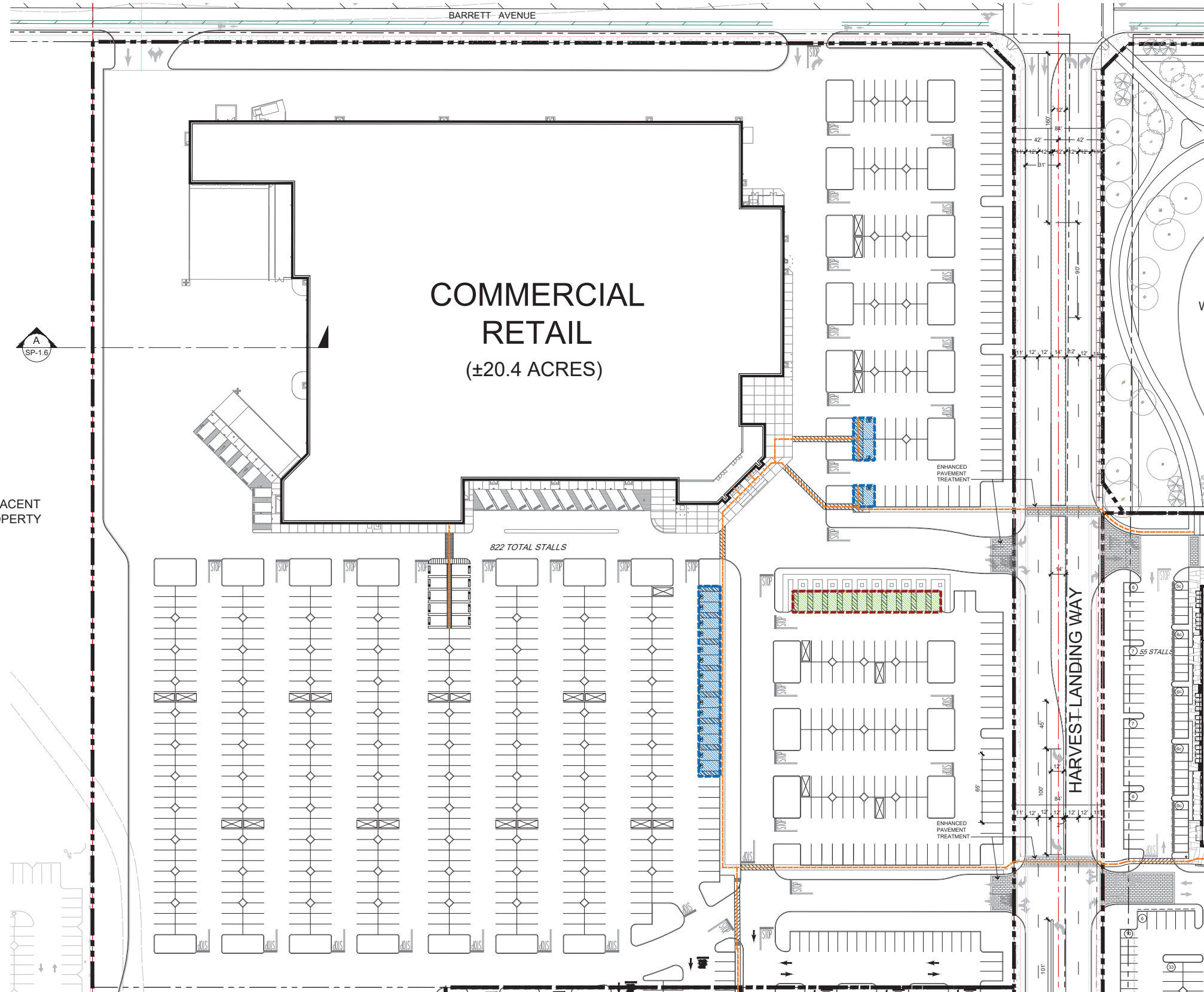

**COMMERCIAL  
RETAIL**  
(±20.4 ACRES)

822 TOTAL STALLS

HARVEST LANDING WAY

WATER QUALITY  
RETENTION  
BASIN

ADJACENT  
PROPERTY

COMMERCIAL/  
RETAIL

**LEGEND (ADDITIONAL)**

	EV PARKING FOR CURRENT PROJECT HAS BEEN BASED ON CBC 2022 AND WILL BE PROVIDING 10 TOTAL LEVEL 3 CHARGERS
	MAIN ADA PARKING PROVIDED TO BE AS CLOSE TO THE BUILDINGS. TOTAL OF 17 ACCESSIBLE SPACES REQUIRED. TOTAL OF 17 ACCESSIBLE SPACES TO BE PROVIDED PER CBC 2022, TABLE 11B-208.2 OF WHICH 3 ARE VAN ACCESSIBLE STALLS.

**PARKING PROVIDED**

STANDARD:	(9'-0" x 19'-0")	795 STALLS
STANDARD ACCESSIBLE PARKING:	(9'-0" x 19'-0")	15 STALLS
VAN ACCESSIBLE PARKING:	(9'-0" x 19'-0")	2 STALLS
EV (DCFC) STALL:	(9'-0" x 19'-0")	10 STALLS
<b>TOTAL PARKING PROVIDED:</b>		<b>822 STALLS</b>
PROPOSED CART CORRALS:	(9'-0" x 19'-0")	25 STALLS

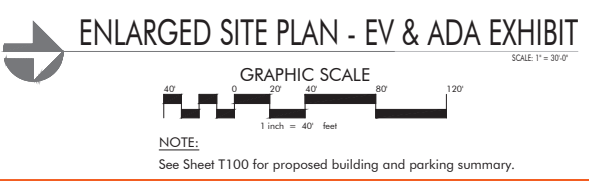

**LEGEND**

	PROPOSED SITE AREA (±20.4 AC)
	NEW BUILDING
	HANDICAP INDICATION PATH OF TRAVEL
	CART CORRAL NOTE: ALL CART CORRALS VISIBLE FROM ADJACENT ROADWAYS MUST BE ENCLOSED AND DECORATED IN MATERIALS AND COLORS COMPLIMENTARY TO COMMERCIAL/RETAIL BUILDINGS.

PRELIMINARY SITE PLAN SUBJECT TO CHANGE. PROPERTY LINES ARE BASED ON CAD DRAWINGS PROVIDED BY CLIENT, PREPARED BY FMCIVIL ENGINEERS INC. RECEIVED FROM CLIENT 06.06.2023.

HIP So-Cal Properties LLC  
2244 N. Pacific Street  
Orange, CA 92865  
TEL. (714) 637-3333



**AZURE DEVELOPMENT CO.**  
944 South Greenwood Avenue  
Montebello, CA 90640  
TEL. (310) 467-7408



**Harvest Landing Retail Center & Business Park**  
SWC Perris Blvd. & Orange Ave., Perris CA 92571

ENLARGED SITE PLAN  
22161MMA | 06.03.2025  
**SP-1.4**

mmaarchitecture.com

**mma  
Architecture**



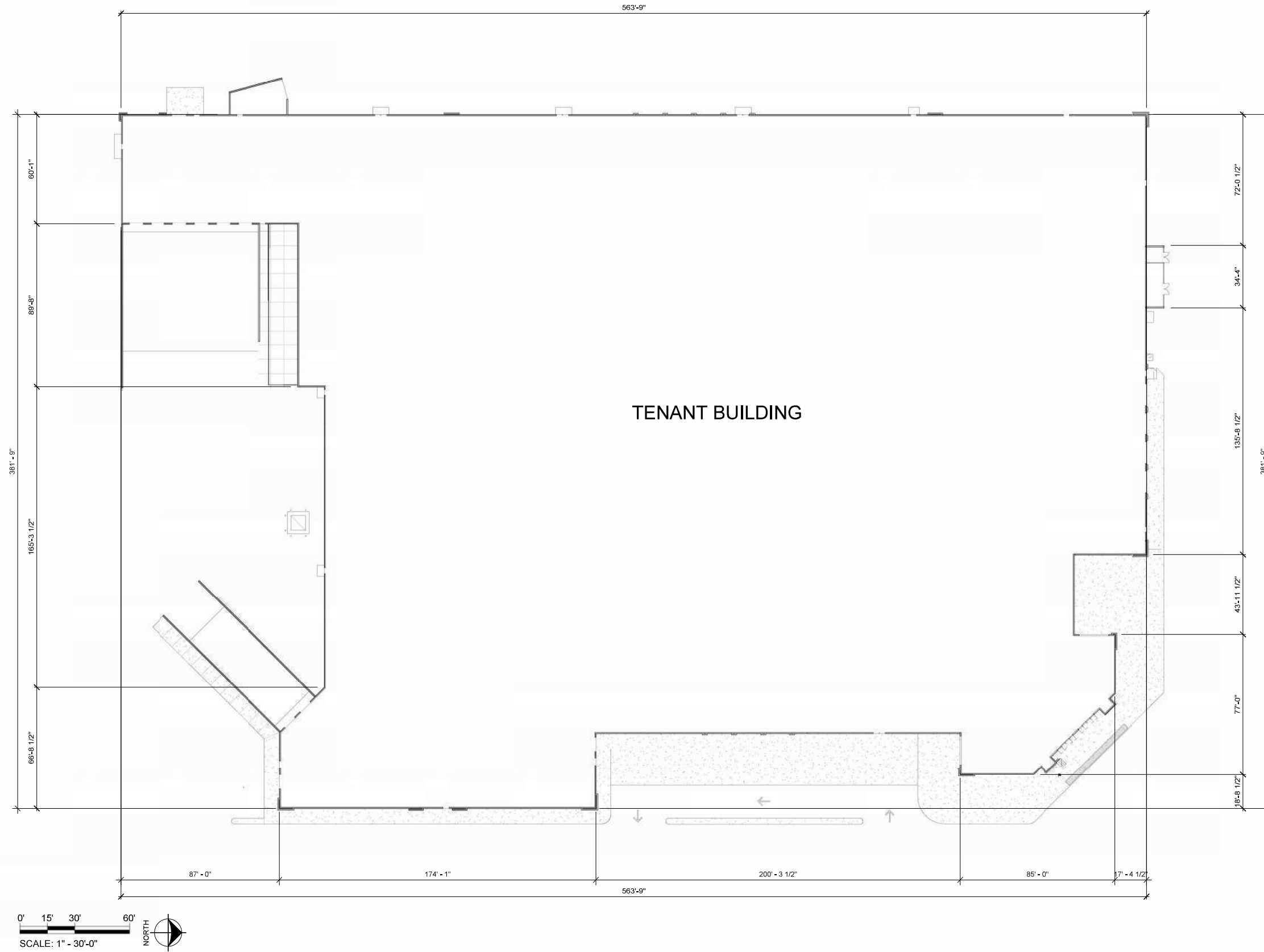

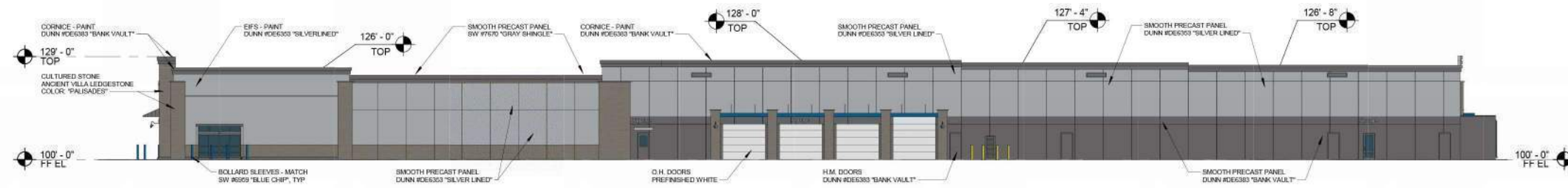

4 NORTH ELEVATION  
1" = 20'-0"

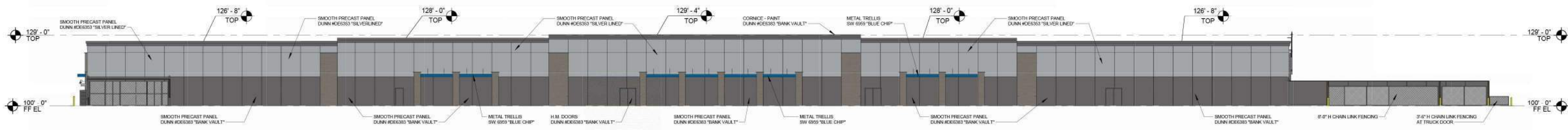

3 WEST ELEVATION  
1" = 20'-0" 12 TBC1

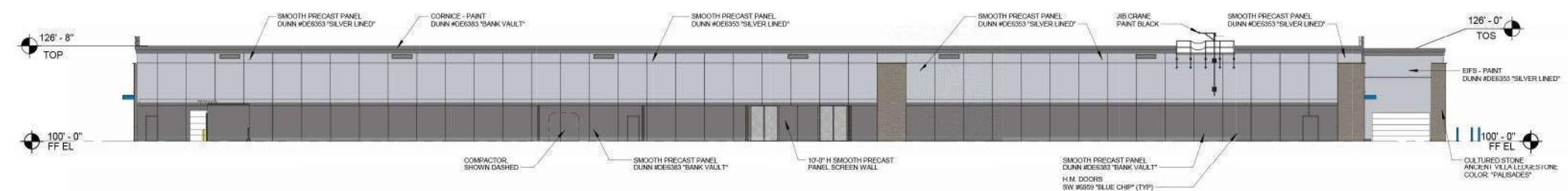

2 SOUTH ELEVATION  
1" = 20'-0"

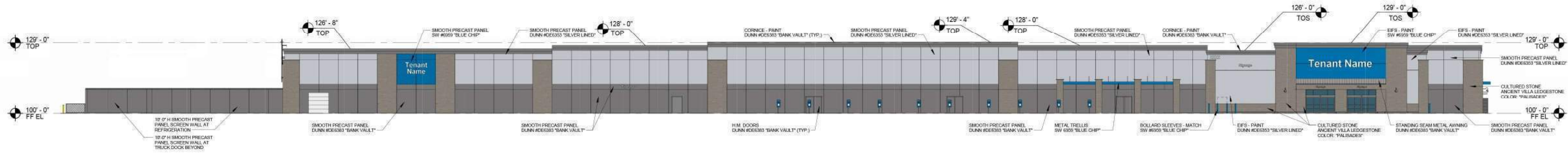

1 EAST ELEVATION  
1" = 20'-0"

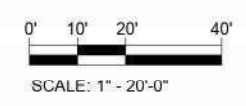

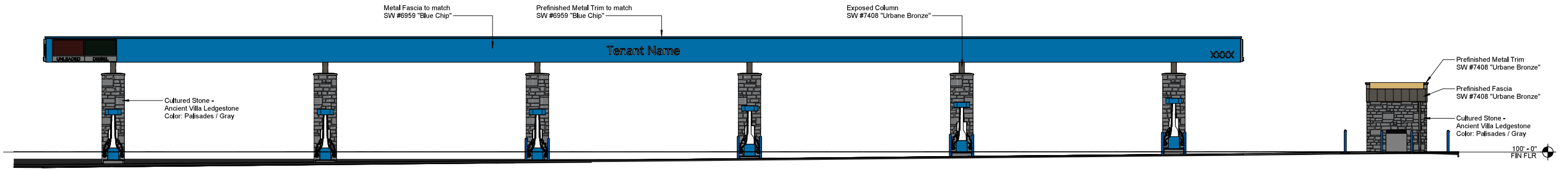

5 FRONT ELEVATION  
1/8" = 1'-0" 1 FSA1

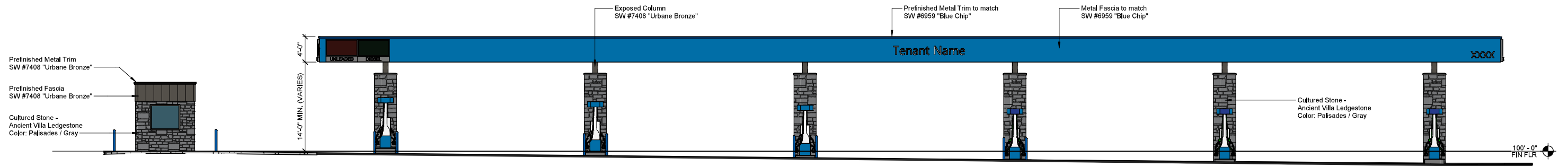

4 BACK ELEVATION  
1/8" = 1'-0" 1 FSA1

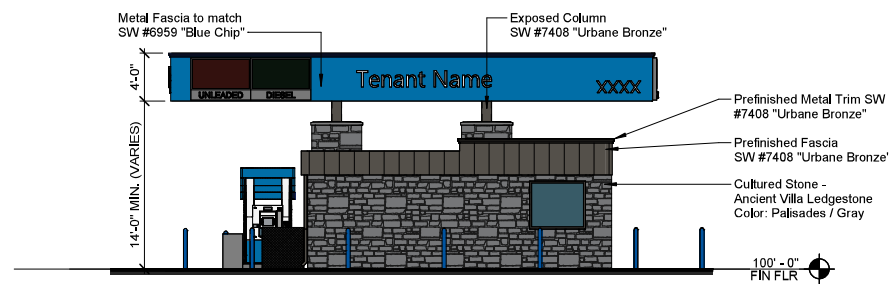

3 SIDE ELEVATION  
1/8" = 1'-0" 1 FSA1

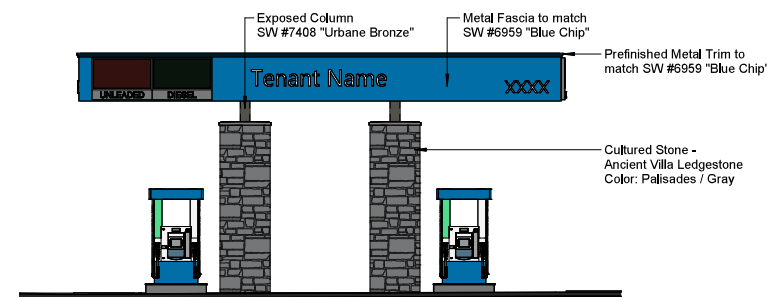

2 SIDE ELEVATION  
1/8" = 1'-0" 1 FSA1

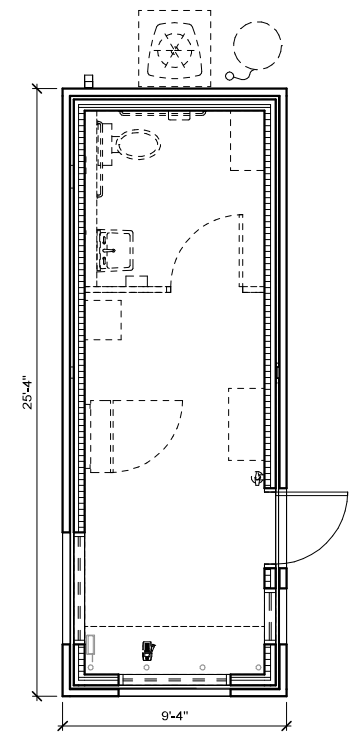

1 OVERALL PLAN  
1/4" = 1'-0" 3 5



**PLANT PALETTE**

Symbol	Botanical Name	Common Name	WUCOLS REGION 4	Stng	Qty
	<i>Chilopsis linearis</i> 'Bubba'	Desert Willow	Low	36" Box Std.	81
	<i>Cercis s.</i> 'Forest Pansy'	Forest Pansy Redbud	Low	24" Box Std.	17
	<i>Geleera parviflora</i>	Australian Willow	Mod	15 Gallon Std.	135
	<i>Lagerstroemia hybrid</i> 'Tucaroza'	Hybrid Crape Myrtle	Low	24" Box Std.	16
	<i>Lagerstroemia l.</i> 'Natchez'	Natchez Crape Myrtle	Mod	24" Box Std.	25
	<i>Olea europaea</i> 'Wilsoni'	Fruitless Olive	Low	48" Box Multi.	14
	<i>Pinus eldarica</i>	Mandel Pine	Low	24" Box Std.	96
	<i>Platanus x acerifolia</i>	London Plane Tree	Mod	24" Box Std.	36
	<i>Platanus racemosa</i>	California Sycamore	Low	48" Box Multi.	3
	<i>Pyrus catusyana</i> 'Chanticleer'	Chanticleer Pear	Mod	24" Box Std.	79
	<i>Quercus r.</i> 'Fastigiata'	English Oak	Mod	36" Box Std.	59
	<i>Tristania conferta</i>	Brisbane Box	Mod	24" Box Std.	76
	<i>Ulmus parvifolia</i> 'Dalei'	Dalei Evergreen Chinese Elm	Low	15 Gallon Std.	55
	<i>Zelkova serota</i> 'City Sprite'	City Sprite Zelkova	Mod	36" Box Std.	113

**SHRUBS/ GROUNDCOVERS**

Symbol	Botanical Name	Common Name	WUCOLS REGION 4
	<i>Agave s.</i> 'Variegata'	Variegated Smooth Agave	Low
	<i>Aloe Blue EF</i>	Blue EF Aloe	Low
	<i>Arigoanthus flavidus</i>	Kangaroo Paw	Low
	<i>Baccharis p.</i> 'Twin Peaks'	Coyote Bush	Low
	<i>Cassipouira gillessii</i>	Mexican Bird of Paradise	Low
	<i>Callistemon v.</i> 'Little John'	Dwarf Bottlebrush	Low
	<i>Cistus purpureus</i>	Cistus Rock Rose	Low
	<i>Daylily wheelset</i>	Desert Spoon	Low
	<i>Eremophila g.</i> 'Mingnew Gold'	Gold Emu Bush	Low
	<i>Furcraea f.</i> 'Mediopicta'	Mauflus Hemp	Low
	<i>Grewia lanigera</i> 'Coastal Gem'	Coastal Gem Grevillea	Low
	<i>Muhlenbergia capillaris</i>	Pink Muhly Grass	Low
	<i>Lantana New Gold</i>	New Gold Lantana	Low
	<i>Leucophyllum f.</i> 'Compacta'	Texas Ranger	Low
	<i>Lomandra 'Breeze'</i>	Dwarf Mat Rush	Low
	<i>Lomandra Platinum Beauty'</i>	Platinum Beauty Lomandra	Low
	<i>Leucosiphium f.</i> 'Texas Ranger'	Texas Ranger	Low
	<i>Peristemon s.</i> 'Margarita BOP'	Margarita BOP Blue Bedder	Low
	<i>Rosa Flower Carpet'</i>	Groundcover Rose	Mod
	<i>Rosemarinus s.</i> 'Huntington Carpet'	Creeping Rosemary	Low
	<i>Russelia equisetiformis</i>	Coral Fountain	Mod
	<i>Salvia greggii</i> 'Flame'	Furnaria Red Autumn Sage	Low
	<i>Salvia leucantha</i>	Mexican Bush Sage	Low
	<i>Westringia f.</i> 'Mund'	Mund Coast Rosemary	Low
	<i>Zauschneria californica</i>	California Fuchsia	Low

**ACCENT SHRUBS**

	<i>Agave 'Blue Glow'</i>	Blue Glow Agave	Low
	<i>Aloe Blue EF</i>	Blue EF Aloe	Low
	<i>Bougainvillea 'Raspberry Ice'</i>	Bougainvillea	Low
	<i>Bulbine 'Fufufuena'</i> 'Waldmark'	Silkies Bulbine	Low
	<i>Lavandula 'Meele'</i>	Meele English Lavender	Low

**SCREEN SHRUBS**

	<i>Rhamnus californica</i> 'Eve Case'	Dwarf Coffeeberry	Low
	<i>Westringia 'Blue Gem'</i>	Blue Gem Coast Rosemary	Low

- NOTES**
- PLANT MATERIAL NOT LISTED MAY BE USED, SUBJECT TO APPROVAL BY THE CITY.
  - ALL LANDSCAPE PLANS AND INSTALLATIONS SHALL ADHERE TO CITY DESIGN GUIDELINES, CODES AND REGULATIONS.
  - ALL LANDSCAPE AREAS SHALL RECEIVE AN AUTOMATIC IRRIGATION SYSTEM.
  - ALL LANDSCAPE INSTALLATIONS SHALL BE PERMANENTLY MAINTAINED.

**OFFSITE PLANTING NOTE:**  
REFER TO MASTER DEVELOPER LANDSCAPE PLANS FOR OFFSITE IMPROVEMENTS.

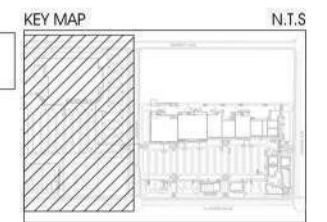

**CONCEPTUAL LANDSCAPE PLAN**  
HARVEST LANDING RETAIL CENTER & BUSINESS PARK  
S.W.C. OF PERRIS BLVD AND ORANGE AVE  
PERRIS, CA 92571



SCALE: 1" = 60'  
CDPC PROJECT NO. 22072  
OCTOBER 30, 2025



conceptual design + planning company  
1475 Serrano Drive, Suite 200  
Costa Mesa, CA 92626  
T: 949.269.0270  
www.cdpc.com



TREES



*Chilopsis linearis* Desert Willow  
*Cercis c.* Forest Pansy Forest Pansy Redbud  
*Geijera parviflora* Australian Willow  
*Lagerstroemia h.* 'Tuscarora' Hybrid Crape Myrtle  
*Lagerstroemia l.* 'Natchez' White Crape Myrtle  
*Olea europaea* 'Wilsoni' Frutless Olive  
*Pinus edulis* Mondell Pine

TREES



*Platanus acerifolia* London Plane Tree  
*Platanus racemosa* California Sycamore  
*Pyrus c.* 'Charitcleer' Callery Pear  
*Quercus f.* 'Fastigiata' Columnar English Oak  
*Tastonia conferta* Brisbane Box  
*Ulmus p.* 'Drake' Drake Evergreen Chinese Elm  
*Zelkova s.* 'City Spire' City Spire Zelkova

SHRUBS



*Agave 'Blue Glow'* Blue Glow Agave  
*Agave d.* 'Variegata' Variegated Smooth Agave  
*Aloe 'Blue Elf'* Blue Elf Aloe  
*Anigozanthos flavidus* Kangaroo Paw  
*Baccharis p.* 'Twin Peaks' Twin Peaks Coyote Bush  
*Bougainvillea 'Raspberry Ice'* Raspberry Ice Bougainvillea  
*Bulbine f.* 'Hallmark' Stalked Bulbine  
*Caesalpinia gilliesii* Mexican Bird Of Paradise  
*Callistemon v.* 'Little John' Dwarf Bottlebrush



*Cistus x purpureus* Orchid Rockrose  
*Dasyliion wheeleri* Desert Spoon  
*Eremophila g.* 'Mingenew Gold' Gold Emu Bush  
*Furcraea f.* 'Mediopicta' Mauritius Hemp  
*Grevillea l.* 'Coastal Gem' Coastal Gem Grevillea  
*Lantana 'New Gold'* New Gold Lantana  
*Lavandula 'Meerlo'* Meerlo Lavender  
*Muhlenbergia capillaris* Pink Muhly Grass  
*Lomandra 'Breeze'* Dwarf Mat Rush  
*Lomandra Platinum Beauty* Platinum Beauty Lomandra  
*Leucophyllum f.* 'Compactum' Compact Texas Ranger



*Penstemon h.* 'Margarita BOP' Margarita BOP Blue Bedder  
*Rhamnus c.* 'Eve Case' Dwarf Coffeeberry  
*Rosa 'Flower Carpet'* Flower Carpet Rose  
*Rosmarinus o.* 'Huntington Carpet' Creeping Rosemary  
*Russelia equisetiformis* Red Firecracker Plant  
*Salvia greggii 'Flame'* Furman's Red Sage  
*Salvia leucantha* Mexican Bush Sage  
*Westingia 'Mundi'* Mundi Coast Rosemary  
*Westingia 'Blue Gem'* Blue Gem Coast Rosemary  
*Zauschneria californica* California Fuchsia







BURGERS

BISTRO BAR

PIZZA & LE



























LEGAL DESCRIPTION

THE BASIS OF THIS LEGAL DESCRIPTION IS A PRELIMINARY TITLE REPORT PREPARED BY FIRST AMERICAN TITLE COMPANY, UNDER ORDER NUMBER NCS-1101318-0NT1 DATED NOVEMBER 23, 2021.

REAL PROPERTY IN THE CITY OF PERRIS, COUNTY OF RIVERSIDE, STATE OF CALIFORNIA, DESCRIBED AS FOLLOWS:

PARCEL 3: (305-100-028, 305-170-018)

THAT PORTION OF THE NORTHWEST QUARTER OF SECTION 19, TOWNSHIP 4 SOUTH, RANGE 3 WEST, SAN BERNARDINO BASE AND MERIDIAN, WHICH LIES EASTERLY OF STATE HIGHWAY 395 AS CONVEYED TO THE STATE OF CALIFORNIA BY DEED RECORDED APRIL 28, 1952 AS INSTRUMENT NO. 18608.

EXCEPTING THE NORTH 30 FEET IN ORANGE AVENUE, THE EAST 30 FEET IN INDIAN AVENUE AND THE SOUTH 30 FEET IN CITRUS AVENUE.

ALSO EXCEPTING THEREFROM THE PORTION DESCRIBED IN DEED RECORDED DECEMBER 21, 1965 AS INSTRUMENT NO. 142400 AND IN DEED RECORDED MARCH 13, 1969 AS INSTRUMENT NO. 24345, RECORDS OF RIVERSIDE COUNTY.

ALSO EXCEPTING THEREFROM THOSE PORTIONS CONVEYED TO THE STATE OF CALIFORNIA BY DEEDS RECORDED MARCH 22, 1992, AS INSTRUMENT NOS. 94602 AND 94603.

PARCEL 4: (305-220-011, 305-220-013, 305-220-018, 305-220-020, 305-220-021, 305-220-023, 305-220-028, 305-220-031, 305-220-038, 305-220-059, 305-220-060, 305-220-061, 305-220-062)

BLOCKS 9, 10, 11 AND 12 OF FIGADOTA FARMS, AS SHOWN BY MAP ON FILE IN THE OFFICE OF THE COUNTY RECORDER OF THE COUNTY OF RIVERSIDE, STATE OF CALIFORNIA, IN BOOK 16 OF MAPS, PAGE 53 THEREOF LYING EAST AND WEST OF FRONTAGE ROAD CONVEYED TO THE STATE OF CALIFORNIA IN A DEED RECORDED MARCH 22, 1991 AS INSTRUMENT NO. 94566.

EXCEPTING THEREFROM ANY PORTION LYING WEST OF THE EAST LINE OF THE PROPERTY CONVEYED TO THE STATE OF CALIFORNIA BY DEEDS RECORDED MARCH 22, 1991, AS INSTRUMENT NO. 94564 AND 94565.

PARCEL 5: (305-110-001, 305-110-002, 305-110-003, 305-110-004, 305-110-005, 305-110-006, 305-110-007, 305-110-015, 305-110-016, 305-110-021, 305-110-022, 305-110-023, 305-110-024, 305-110-025, 305-110-026, 305-110-027)

BLOCKS 1 THROUGH 8, INCLUSIVE OF FIGADOTA FARMS NO. 1A, AS SHOWN BY MAP ON FILE IN THE OFFICE OF THE COUNTY RECORDER OF THE COUNTY OF RIVERSIDE, STATE OF CALIFORNIA, IN BOOK 16 OF MAPS, PAGE 68 THEREOF.

PARCEL 6A: (305-110-032, 305-110-033, 305-110-034, 305-110-035, 305-140-012, 305-140-024, 305-140-025, 305-140-026, 305-140-027, 305-140-034, 305-140-040, 305-140-052)

BLOCKS 1, 2, LOT A BLOCK 3, BLOCKS 10, 11 AND 12, LOT A BLOCK 19 AND BLOCK 20 OF FIGADOTA FARMS NO. 6, AS SHOWN BY MAP ON FILE IN THE OFFICE OF THE COUNTY RECORDER OF THE COUNTY OF RIVERSIDE, STATE OF CALIFORNIA, IN BOOK 16 OF MAPS, PAGE 77 THEREOF.

PARCEL 6B: (305-140-041, 305-140-053)

THOSE PORTIONS OF FIGADOTA FARMS NO. 6, AS SHOWN BY MAP ON FILE IN THE OFFICE OF THE COUNTY RECORDER OF THE COUNTY OF RIVERSIDE, STATE OF CALIFORNIA, IN BOOK 16 OF MAPS, PAGE 77 THEREOF, DESCRIBED AS FOLLOWS:

PARCELS 1 AND 3, IN THE CITY OF PERRIS, COUNTY OF RIVERSIDE, STATE OF CALIFORNIA, AS SHOWN ON THAT CERTAIN "LOT LINE ADJUSTMENT NO. 06-0257", WHICH RECORDED OCTOBER 10, 2006 AS INSTRUMENT NO. 2006-772724 OF OFFICIAL RECORDS, DESCRIBED AS FOLLOWS:

PARCEL 1

ALL OF LOT "B", A PORTION OF LOT "C" IN BLOCK 3, TOGETHER WITH A PORTION OF THE EAST ONE-HALF OF BARRETT AVENUE (VACATED) OF FIGADOTA FARMS NO. 6, AS SHOWN BY MAP ON FILE IN BOOK 16, PAGE 77, RECORDS OF RIVERSIDE COUNTY, CALIFORNIA, LYING NORTHERLY OF THE FOLLOWING DESCRIBED LINE:

COMMENCING AT THE CENTERLINE INTERSECTION OF CITRUS AVENUE (VACATED) AND PERRIS BOULEVARD (50.00 FOOT IN HALF WIDTH) AS SHOWN ON SAID MAP; THENCE NORTH 00° 30' 55" EAST ALONG SAID CENTERLINE OF PERRIS BOULEVARD, A DISTANCE OF 373.59 FEET; THENCE NORTH 89° 28' 41" WEST, A DISTANCE OF 50.00 FEET TO A POINT ON THE WESTERLY RIGHT OF WAY LINE OF SAID PERRIS BOULEVARD, SAID POINT ALSO BEING THE POINT OF BEGINNING; THENCE CONTINUING NORTH 89° 28' 41" WEST, A DISTANCE OF 1271.20 FEET TO A POINT ON THE CENTERLINE OF BARRETT AVENUE (VACATED), AS SHOWN ON SAID MAP, SAID POINT BEING NORTH 00° 37' 11" EAST AND DISTANT 380.02 FEET FROM THE CENTERLINE INTERSECTION OF SAID CITRUS AVENUE (VACATED) AND SAID BARRETT AVENUE (VACATED), SAID POINT ALSO BEING THE POINT OF TERMINUS OF DESCRIBED LINE.

PARCEL 3

ALL OF LOT "A" IN BLOCK 9 AND A PORTION OF LOT "A" IN BLOCK 8, TOGETHER WITH A PORTION OF THE SOUTH ONE-HALF OF LEMON AVENUE (VACATED) OF FIGADOTA FARMS NO. 6, AS SHOWN BY MAP ON FILE IN BOOK 16, PAGE 77, RECORDS OF RIVERSIDE COUNTY, CALIFORNIA, LYING NORTHERLY OF THE FOLLOWING DESCRIBED LINE:

COMMENCING AT THE CENTERLINE INTERSECTION OF CITRUS AVENUE (VACATED) AND PERRIS BOULEVARD (50.00 FOOT IN HALF WIDTH) AS SHOWN ON SAID MAP; THENCE NORTH 00° 30' 55" EAST ALONG SAID CENTERLINE OF PERRIS BOULEVARD, A DISTANCE OF 373.59 FEET; THENCE NORTH 89° 28' 41" WEST, A DISTANCE OF 50.00 FEET TO A POINT ON THE WESTERLY RIGHT OF WAY LINE OF SAID PERRIS BOULEVARD, SAID POINT ALSO BEING THE POINT OF BEGINNING; THENCE CONTINUING NORTH 89° 28' 41" WEST, A DISTANCE OF 1271.20 FEET TO A POINT ON THE CENTERLINE OF BARRETT AVENUE (VACATED), AS SHOWN ON SAID MAP, SAID POINT BEING NORTH 00° 37' 11" EAST AND DISTANT 380.02 FEET FROM THE CENTERLINE INTERSECTION OF SAID CITRUS AVENUE (VACATED) AND SAID BARRETT AVENUE (VACATED), SAID POINT ALSO BEING THE POINT OF TERMINUS OF DESCRIBED LINE.

PARCEL 6C: (305-140-031, 305-140-032, 305-140-049, 305-140-050)

THOSE PORTIONS OF FIGADOTA FARMS NO. 6, AS SHOWN BY MAP ON FILE IN THE OFFICE OF THE COUNTY RECORDER OF THE COUNTY OF RIVERSIDE, STATE OF CALIFORNIA, IN BOOK 16 OF MAPS, PAGE 77 THEREOF, DESCRIBED AS FOLLOWS:

PARCELS 1 AND 2, IN THE CITY OF PERRIS, COUNTY OF RIVERSIDE, STATE OF CALIFORNIA, AS SHOWN ON THAT CERTAIN "LOT LINE ADJUSTMENT NO. 06-0258", WHICH RECORDED OCTOBER 10, 2006 AS INSTRUMENT NO. 2006-772725 OF OFFICIAL RECORDS, DESCRIBED AS FOLLOWS:

PARCEL 1

ALL OF LOT "C" IN BLOCK 13 AND A PORTION OF LOT "C" IN BLOCK 14, TOGETHER WITH A PORTION OF THE SOUTH ONE-HALF OF LEMON AVENUE (VACATED) OF FIGADOTA FARMS NO. 6, AS SHOWN BY MAP ON FILE IN BOOK 16, PAGE 77, RECORDS OF RIVERSIDE COUNTY, CALIFORNIA, LYING NORTHERLY OF THE FOLLOWING DESCRIBED LINE:

COMMENCING AT THE CENTERLINE INTERSECTION OF CITRUS AVENUE (VACATED) AND PERRIS BOULEVARD (50.00 FOOT IN HALF WIDTH) AS SHOWN ON SAID MAP; THENCE NORTH 00° 30' 55" EAST ALONG SAID CENTERLINE OF PERRIS BOULEVARD, A DISTANCE OF 373.59 FEET; THENCE NORTH 89° 28' 41" WEST, A DISTANCE OF 50.00 FEET TO A POINT ON THE WESTERLY RIGHT OF WAY LINE OF SAID PERRIS BOULEVARD, SAID POINT ALSO BEING THE POINT OF BEGINNING; THENCE CONTINUING NORTH 89° 28' 41" WEST, A DISTANCE OF 1271.20 FEET TO A POINT ON THE CENTERLINE OF BARRETT AVENUE (VACATED), AS SHOWN ON SAID MAP, SAID POINT BEING NORTH 00° 37' 11" EAST AND DISTANT 380.02 FEET FROM THE CENTERLINE INTERSECTION OF SAID CITRUS AVENUE (VACATED) AND SAID BARRETT AVENUE (VACATED), SAID POINT ALSO BEING THE POINT OF TERMINUS OF DESCRIBED LINE.

PARCEL 2

ALL OF LOT "D" IN BLOCK 13 AND A PORTION OF LOT "D" IN BLOCK 14, TOGETHER WITH A PORTION OF THE SOUTH ONE-HALF OF LEMON AVENUE (VACATED) OF FIGADOTA FARMS NO. 6, AS SHOWN BY MAP ON FILE IN BOOK 16, PAGE 77, RECORDS OF RIVERSIDE COUNTY, CALIFORNIA, LYING NORTHERLY OF THE FOLLOWING DESCRIBED LINE:

IN THE CITY OF PERRIS, COUNTY OF RIVERSIDE, STATE OF CALIFORNIA HARVEST LANDING RETAIL CENTER AND BUSINESS PARK TENTATIVE PARCEL MAP 38811 SURVEYORS' NOTES

LEGAL DESCRIPTION

PARCEL 6D: PARCEL 2 (CONTINUED)

COMMENCING AT THE CENTERLINE INTERSECTION OF CITRUS AVENUE (VACATED) AND PERRIS BOULEVARD (50.00 FOOT IN HALF WIDTH) AS SHOWN ON SAID MAP; THENCE NORTH 00° 30' 55" EAST ALONG SAID CENTERLINE OF PERRIS BOULEVARD, A DISTANCE OF 373.59 FEET; THENCE NORTH 89° 28' 41" WEST, A DISTANCE OF 50.00 FEET TO A POINT ON THE WESTERLY RIGHT OF WAY LINE OF SAID PERRIS BOULEVARD, SAID POINT ALSO BEING THE POINT OF BEGINNING; THENCE CONTINUING NORTH 89° 28' 41" WEST, A DISTANCE OF 1271.20 FEET TO A POINT ON THE CENTERLINE OF BARRETT AVENUE (VACATED), AS SHOWN ON SAID MAP, SAID POINT BEING NORTH 00° 37' 11" EAST AND DISTANT 380.02 FEET FROM THE CENTERLINE INTERSECTION OF SAID CITRUS AVENUE (VACATED) AND SAID BARRETT AVENUE (VACATED), SAID POINT ALSO BEING THE POINT OF TERMINUS OF DESCRIBED LINE.

PARCEL 6D: (305-140-054, 305-140-055)

THOSE PORTIONS OF FIGADOTA FARMS NO. 6, AS SHOWN BY MAP ON FILE IN THE OFFICE OF THE COUNTY RECORDER OF THE COUNTY OF RIVERSIDE, STATE OF CALIFORNIA, IN BOOK 16 OF MAPS, PAGE 77 THEREOF, DESCRIBED AS FOLLOWS:

PARCELS 1 AND 2, IN THE CITY OF PERRIS, COUNTY OF RIVERSIDE, STATE OF CALIFORNIA, AS SHOWN ON THAT CERTAIN "LOT LINE ADJUSTMENT NO. 06-0259", WHICH RECORDED OCTOBER 10, 2006 AS INSTRUMENT NO. 2006-772726 OF OFFICIAL RECORDS, DESCRIBED AS FOLLOWS:

PARCEL 1

ALL OF LOT "B" IN BLOCK 9 AND A PORTION OF LOT "B" IN BLOCK 8, TOGETHER WITH A PORTION OF THE SOUTH ONE-HALF OF LEMON AVENUE (VACATED) OF FIGADOTA FARMS NO. 6, AS SHOWN BY MAP ON FILE IN BOOK 16, PAGE 77, RECORDS OF RIVERSIDE COUNTY, CALIFORNIA, LYING NORTHERLY OF THE FOLLOWING DESCRIBED LINE:

COMMENCING AT THE CENTERLINE INTERSECTION OF CITRUS AVENUE (VACATED) AND PERRIS BOULEVARD (50.00 FOOT IN HALF WIDTH) AS SHOWN ON SAID MAP; THENCE NORTH 00° 30' 55" EAST ALONG SAID CENTERLINE OF PERRIS BOULEVARD, A DISTANCE OF 373.59 FEET; THENCE NORTH 89° 28' 41" WEST, A DISTANCE OF 50.00 FEET TO A POINT ON THE WESTERLY RIGHT OF WAY LINE OF SAID PERRIS BOULEVARD, SAID POINT ALSO BEING THE POINT OF BEGINNING; THENCE CONTINUING NORTH 89° 28' 41" WEST, A DISTANCE OF 1271.20 FEET TO A POINT ON THE CENTERLINE OF BARRETT AVENUE (VACATED), AS SHOWN ON SAID MAP, SAID POINT BEING NORTH 00° 37' 11" EAST AND DISTANT 380.02 FEET FROM THE CENTERLINE INTERSECTION OF SAID CITRUS AVENUE (VACATED) AND SAID BARRETT AVENUE (VACATED), SAID POINT ALSO BEING THE POINT OF TERMINUS OF DESCRIBED LINE.

PARCEL 2

ALL OF LOT "C" IN BLOCK 9 AND A PORTION OF LOT "C" IN BLOCK 8, TOGETHER WITH A PORTION OF THE SOUTH ONE-HALF OF LEMON AVENUE (VACATED) OF FIGADOTA FARMS NO. 6, AS SHOWN BY MAP ON FILE IN BOOK 16, PAGE 77, RECORDS OF RIVERSIDE COUNTY, CALIFORNIA, LYING NORTHERLY OF THE FOLLOWING DESCRIBED LINE:

COMMENCING AT THE CENTERLINE INTERSECTION OF CITRUS AVENUE (VACATED) AND PERRIS BOULEVARD (50.00 FOOT IN HALF WIDTH) AS SHOWN ON SAID MAP; THENCE NORTH 00° 30' 55" EAST ALONG SAID CENTERLINE OF PERRIS BOULEVARD, A DISTANCE OF 373.59 FEET; THENCE NORTH 89° 28' 41" WEST, A DISTANCE OF 50.00 FEET TO A POINT ON THE WESTERLY RIGHT OF WAY LINE OF SAID PERRIS BOULEVARD, SAID POINT ALSO BEING THE POINT OF BEGINNING; THENCE CONTINUING NORTH 89° 28' 41" WEST, A DISTANCE OF 1271.20 FEET TO A POINT ON THE CENTERLINE OF BARRETT AVENUE (VACATED), AS SHOWN ON SAID MAP, SAID POINT BEING NORTH 00° 37' 11" EAST AND DISTANT 380.02 FEET FROM THE CENTERLINE INTERSECTION OF SAID CITRUS AVENUE (VACATED) AND SAID BARRETT AVENUE (VACATED), SAID POINT ALSO BEING THE POINT OF TERMINUS OF DESCRIBED LINE.

PARCEL 6E: (305-140-056, 305-140-057)

THOSE PORTIONS OF FIGADOTA FARMS NO. 6, AS SHOWN BY MAP ON FILE IN THE OFFICE OF THE COUNTY RECORDER OF THE COUNTY OF RIVERSIDE, STATE OF CALIFORNIA, IN BOOK 16 OF MAPS, PAGE 77 THEREOF, DESCRIBED AS FOLLOWS:

PARCELS 1 AND 2, IN THE CITY OF PERRIS, COUNTY OF RIVERSIDE, STATE OF CALIFORNIA, AS SHOWN ON THAT CERTAIN "LOT LINE ADJUSTMENT NO. 06-0260", WHICH RECORDED OCTOBER 10, 2006 AS INSTRUMENT NO. 2006-772727 OF OFFICIAL RECORDS, DESCRIBED AS FOLLOWS:

PARCEL 1

ALL OF LOT "D" IN BLOCK 9 AND A PORTION OF LOT "D" IN BLOCK 8, TOGETHER WITH A PORTION OF THE SOUTH ONE-HALF OF LEMON AVENUE (VACATED) OF FIGADOTA FARMS NO. 6, AS SHOWN BY MAP ON FILE IN BOOK 16, PAGE 77, RECORDS OF RIVERSIDE COUNTY, CALIFORNIA, LYING NORTHERLY OF THE FOLLOWING DESCRIBED LINE:

COMMENCING AT THE CENTERLINE INTERSECTION OF CITRUS AVENUE (VACATED) AND PERRIS BOULEVARD (50.00 FOOT IN HALF WIDTH) AS SHOWN ON SAID MAP; THENCE NORTH 00° 30' 55" EAST ALONG SAID CENTERLINE OF PERRIS BOULEVARD, A DISTANCE OF 373.59 FEET; THENCE NORTH 89° 28' 41" WEST, A DISTANCE OF 50.00 FEET TO A POINT ON THE WESTERLY RIGHT OF WAY LINE OF SAID PERRIS BOULEVARD, SAID POINT ALSO BEING THE POINT OF BEGINNING; THENCE CONTINUING NORTH 89° 28' 41" WEST, A DISTANCE OF 1271.20 FEET TO A POINT ON THE CENTERLINE OF BARRETT AVENUE (VACATED), AS SHOWN ON SAID MAP, SAID POINT BEING NORTH 00° 37' 11" EAST AND DISTANT 380.02 FEET FROM THE CENTERLINE INTERSECTION OF SAID CITRUS AVENUE (VACATED) AND SAID BARRETT AVENUE (VACATED), SAID POINT ALSO BEING THE POINT OF TERMINUS OF DESCRIBED LINE.

PARCEL 2

ALL OF LOT "E" IN BLOCK 9 AND A PORTION OF LOT "E" IN BLOCK 8, TOGETHER WITH A PORTION OF THE SOUTH ONE-HALF OF LEMON AVENUE (VACATED) OF FIGADOTA FARMS NO. 6, AS SHOWN BY MAP ON FILE IN BOOK 16, PAGE 77, RECORDS OF RIVERSIDE COUNTY, CALIFORNIA, LYING NORTHERLY OF THE FOLLOWING DESCRIBED LINE:

COMMENCING AT THE CENTERLINE INTERSECTION OF CITRUS AVENUE (VACATED) AND PERRIS BOULEVARD (50.00 FOOT IN HALF WIDTH) AS SHOWN ON SAID MAP; THENCE NORTH 00° 30' 55" EAST ALONG SAID CENTERLINE OF PERRIS BOULEVARD, A DISTANCE OF 373.59 FEET; THENCE NORTH 89° 28' 41" WEST, A DISTANCE OF 50.00 FEET TO A POINT ON THE WESTERLY RIGHT OF WAY LINE OF SAID PERRIS BOULEVARD, SAID POINT ALSO BEING THE POINT OF BEGINNING; THENCE CONTINUING NORTH 89° 28' 41" WEST, A DISTANCE OF 1271.20 FEET TO A POINT ON THE CENTERLINE OF BARRETT AVENUE (VACATED), AS SHOWN ON SAID MAP, SAID POINT BEING NORTH 00° 37' 11" EAST AND DISTANT 380.02 FEET FROM THE CENTERLINE INTERSECTION OF SAID CITRUS AVENUE (VACATED) AND SAID BARRETT AVENUE (VACATED), SAID POINT ALSO BEING THE POINT OF TERMINUS OF DESCRIBED LINE.

PARCEL 6F: (305-140-060, 305-140-061)

THOSE PORTIONS OF FIGADOTA FARMS NO. 6, AS SHOWN BY MAP ON FILE IN THE OFFICE OF THE COUNTY RECORDER OF THE COUNTY OF RIVERSIDE, STATE OF CALIFORNIA, IN BOOK 16 OF MAPS, PAGE 77 THEREOF, DESCRIBED AS FOLLOWS:

PARCELS 1 AND 2, IN THE CITY OF PERRIS, COUNTY OF RIVERSIDE, STATE OF CALIFORNIA, AS SHOWN ON THAT CERTAIN "LOT LINE ADJUSTMENT NO. 06-0261", WHICH RECORDED OCTOBER 10, 2006 AS INSTRUMENT NO. 2006-772728 OF OFFICIAL RECORDS, DESCRIBED AS FOLLOWS:

LEGAL DESCRIPTION

PARCEL 6F: (CONTINUED)

PARCEL 1

ALL OF LOT "E" IN BLOCK 13 AND A PORTION OF LOT "E" IN BLOCK 14, TOGETHER WITH A PORTION OF THE SOUTH ONE-HALF OF LEMON AVENUE (VACATED) OF FIGADOTA FARMS NO. 6, AS SHOWN BY MAP ON FILE IN BOOK 16, PAGE 77, RECORDS OF RIVERSIDE COUNTY, CALIFORNIA, LYING NORTHERLY OF THE FOLLOWING DESCRIBED LINE:

COMMENCING AT THE CENTERLINE INTERSECTION OF CITRUS AVENUE (VACATED) AND PERRIS BOULEVARD (50.00 FOOT IN HALF WIDTH) AS SHOWN ON SAID MAP; THENCE NORTH 00° 30' 55" EAST ALONG SAID CENTERLINE OF PERRIS BOULEVARD, A DISTANCE OF 373.59 FEET; THENCE NORTH 89° 28' 41" WEST, A DISTANCE OF 50.00 FEET TO A POINT ON THE WESTERLY RIGHT OF WAY LINE OF SAID PERRIS BOULEVARD, SAID POINT ALSO BEING THE POINT OF BEGINNING; THENCE CONTINUING NORTH 89° 28' 41" WEST, A DISTANCE OF 1271.20 FEET TO A POINT ON THE CENTERLINE OF BARRETT AVENUE (VACATED), AS SHOWN ON SAID MAP, SAID POINT BEING NORTH 00° 37' 11" EAST AND DISTANT 380.02 FEET FROM THE CENTERLINE INTERSECTION OF SAID CITRUS AVENUE (VACATED) AND SAID BARRETT AVENUE (VACATED), SAID POINT ALSO BEING THE POINT OF TERMINUS OF DESCRIBED LINE.

PARCEL 2

ALL OF LOT "B" IN BLOCK 19 AND A PORTION OF LOT "C" IN BLOCK 19 OF FIGADOTA FARMS NO. 6, AS SHOWN BY MAP ON FILE IN BOOK 16, PAGE 77, RECORDS OF RIVERSIDE COUNTY, CALIFORNIA, LYING NORTHERLY OF THE FOLLOWING DESCRIBED LINE:

COMMENCING AT THE CENTERLINE INTERSECTION OF CITRUS AVENUE (VACATED) AND PERRIS BOULEVARD (50.00 FOOT IN HALF WIDTH) AS SHOWN ON SAID MAP; THENCE NORTH 00° 30' 55" EAST ALONG SAID CENTERLINE OF PERRIS BOULEVARD, A DISTANCE OF 373.59 FEET; THENCE NORTH 89° 28' 41" WEST, A DISTANCE OF 50.00 FEET TO A POINT ON THE WESTERLY RIGHT OF WAY LINE OF SAID PERRIS BOULEVARD, SAID POINT ALSO BEING THE POINT OF BEGINNING; THENCE CONTINUING NORTH 89° 28' 41" WEST, A DISTANCE OF 1271.20 FEET TO A POINT ON THE CENTERLINE OF BARRETT AVENUE (VACATED), AS SHOWN ON SAID MAP, SAID POINT BEING NORTH 00° 37' 11" EAST AND DISTANT 380.02 FEET FROM THE CENTERLINE INTERSECTION OF SAID CITRUS AVENUE (VACATED) AND SAID BARRETT AVENUE (VACATED), SAID POINT ALSO BEING THE POINT OF TERMINUS OF DESCRIBED LINE.

PARCEL 6G: (305-140-058, 305-140-059)

THOSE PORTIONS OF FIGADOTA FARMS NO. 6, AS SHOWN BY MAP ON FILE IN THE OFFICE OF THE COUNTY RECORDER OF THE COUNTY OF RIVERSIDE, STATE OF CALIFORNIA, IN BOOK 16 OF MAPS, PAGE 77 THEREOF, DESCRIBED AS FOLLOWS:

PARCELS 1 AND 2, IN THE CITY OF PERRIS, COUNTY OF RIVERSIDE, STATE OF CALIFORNIA, AS SHOWN ON THAT CERTAIN "LOT LINE ADJUSTMENT NO. 06-0262", WHICH RECORDED OCTOBER 10, 2006 AS INSTRUMENT NO. 2006-772729 OF OFFICIAL RECORDS, DESCRIBED AS FOLLOWS:

PARCEL 1

ALL OF LOT "A" IN BLOCK 13 AND A PORTION OF LOT "A" IN BLOCK 14, TOGETHER WITH A PORTION OF THE SOUTH ONE-HALF OF LEMON AVENUE (VACATED) OF FIGADOTA FARMS NO. 6, AS SHOWN BY MAP ON FILE IN BOOK 16, PAGE 77, RECORDS OF RIVERSIDE COUNTY, CALIFORNIA, LYING NORTHERLY OF THE FOLLOWING DESCRIBED LINE:

COMMENCING AT THE CENTERLINE INTERSECTION OF CITRUS AVENUE (VACATED) AND PERRIS BOULEVARD (50.00 FOOT IN HALF WIDTH) AS SHOWN ON SAID MAP; THENCE NORTH 00° 30' 55" EAST ALONG SAID CENTERLINE OF PERRIS BOULEVARD, A DISTANCE OF 373.59 FEET; THENCE NORTH 89° 28' 41" WEST, A DISTANCE OF 50.00 FEET TO A POINT ON THE WESTERLY RIGHT OF WAY LINE OF SAID PERRIS BOULEVARD, SAID POINT ALSO BEING THE POINT OF BEGINNING; THENCE CONTINUING NORTH 89° 28' 41" WEST, A DISTANCE OF 1271.20 FEET TO A POINT ON THE CENTERLINE OF BARRETT AVENUE (VACATED), AS SHOWN ON SAID MAP, SAID POINT BEING NORTH 00° 37' 11" EAST AND DISTANT 380.02 FEET FROM THE CENTERLINE INTERSECTION OF SAID CITRUS AVENUE (VACATED) AND SAID BARRETT AVENUE (VACATED), SAID POINT ALSO BEING THE POINT OF TERMINUS OF DESCRIBED LINE.

PARCEL 2

ALL OF LOT "B" IN BLOCK 13 AND A PORTION OF LOT "B" IN BLOCK 14, TOGETHER WITH A PORTION OF THE SOUTH ONE-HALF OF LEMON AVENUE (VACATED) OF FIGADOTA FARMS NO. 6, AS SHOWN BY MAP ON FILE IN BOOK 16, PAGE 77, RECORDS OF RIVERSIDE COUNTY, CALIFORNIA, LYING NORTHERLY OF THE FOLLOWING DESCRIBED LINE:

COMMENCING AT THE CENTERLINE INTERSECTION OF CITRUS AVENUE (VACATED) AND PERRIS BOULEVARD (50.00 FOOT IN HALF WIDTH) AS SHOWN ON SAID MAP; THENCE NORTH 00° 30' 55" EAST ALONG SAID CENTERLINE OF PERRIS BOULEVARD, A DISTANCE OF 373.59 FEET; THENCE NORTH 89° 28' 41" WEST, A DISTANCE OF 50.00 FEET TO A POINT ON THE WESTERLY RIGHT OF WAY LINE OF SAID PERRIS BOULEVARD, SAID POINT ALSO BEING THE POINT OF BEGINNING; THENCE CONTINUING NORTH 89° 28' 41" WEST, A DISTANCE OF 1271.20 FEET TO A POINT ON THE CENTERLINE OF BARRETT AVENUE (VACATED), AS SHOWN ON SAID MAP, SAID POINT BEING NORTH 00° 37' 11" EAST AND DISTANT 380.02 FEET FROM THE CENTERLINE INTERSECTION OF SAID CITRUS AVENUE (VACATED) AND SAID BARRETT AVENUE (VACATED), SAID POINT ALSO BEING THE POINT OF TERMINUS OF DESCRIBED LINE.

PARCEL 7: (305-120-004, 305-120-005, 305-120-006, 305-120-007, 305-120-008, 305-120-020, 305-120-021, 305-120-022, 305-120-023, 305-120-024, 305-120-025, 305-120-026, 305-130-001, 305-130-002, 305-130-003, 305-130-004, 305-130-005, 305-130-006, 305-130-009, 305-160-001, 305-160-002, 305-160-003, 305-160-004, 305-160-005, 305-160-006, 305-160-007, 305-160-008, 305-160-009, 305-160-010, 305-160-011, 305-160-012, 305-160-013, 305-160-014, 305-160-015, 305-160-016, 305-160-017, 305-160-018, 305-160-019, 305-160-020, 305-160-021, 305-160-022, 305-160-023, 305-160-024, 305-160-025, 305-160-026, 305-160-027, 305-160-028, 305-160-029, 305-160-030, 305-190-014, 305-190-019, 305-190-020, 305-190-028, 305-190-029, 305-190-030, 305-190-031, 305-190-033)

LOTS 1 THROUGH 8, INCLUSIVE AND 13 THROUGH 20 INCLUSIVE, OF FIGADOTA FARMS, AS SHOWN BY MAP ON FILE IN THE OFFICE OF THE COUNTY RECORDER OF THE COUNTY OF RIVERSIDE, STATE OF CALIFORNIA, IN BOOK 16 OF MAPS, PAGE 53 THEREOF.

EXCEPT THOSE PORTIONS OF LOTS 7 AND 8 LYING WEST OF THE EAST LINE OF FRONTAGE ROAD AND HIGHWAY 395 AS CONVEYED TO THE STATE OF CALIFORNIA BY DEEDS RECORDED MARCH 22, 1991 AS INSTRUMENT NOS. 94564, 94565 AND 94566, ALL OF OFFICIAL RECORDS.

BASIS OF BEARINGS

THE BASIS OF BEARINGS FOR THIS SURVEY IS THE CALIFORNIA STATE PLANE COORDINATE SYSTEM, CC83, ZONE 6, BASED LOCALLY ON CONTROL STATIONS "40 Y" AND "435" NAD83(NRS2007). ALL BEARINGS SHOWN ON THIS MAP ARE GRID. QUOTED BEARINGS AND DISTANCES FROM REFERENCE MAPS OR DEEDS ARE AS SHOWN PER THAT RECORD REFERENCE. ALL DISTANCES SHOWN DISTANCES SHOWN ARE GROUND DISTANCES UNLESS SPECIFIED OTHERWISE. GRID DISTANCES MAY BE OBTAINED BY MULTIPLYING THE GROUND DISTANCE BY A COMBINATION FACTOR OF 0.99992452. CALCULATIONS ARE MADE AT "40 Y" WITH COORDINATES OF: N2,245,643.330, E6,275,631.960, USING AN ELEVATION OF 1493.77'.

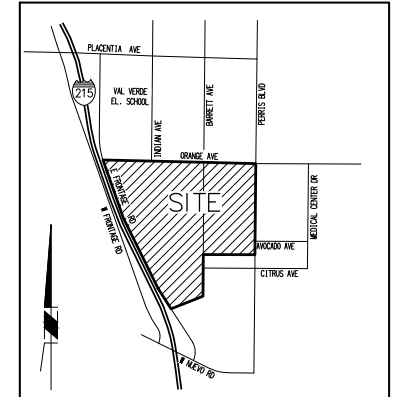

VICINITY MAP

T4S, R3W, SEC 19 NOT TO SCALE

GENERAL INFORMATION

Table with 2 columns: Item and Description. Includes total gross acreage (212.50 ACRES), existing land use (LIGHT AGRICULTURE), proposed land use (BUSINESS PARK), and zoning information.

AERIAL IMAGERY SOURCE

INLAND AERIAL SURVEYS, DECEMBER 2022.

ASSESSOR'S PARCEL NUMBERS:

List of Assessor's Parcel Numbers (APNs) for the site, including 305-100-028, 305-170-018, 305-220-011, 305-220-013, 305-220-018, 305-220-020, 305-220-021, 305-220-023, 305-220-028, 305-220-031, 305-220-038, 305-220-059, 305-220-060, 305-220-061, 305-220-062, 305-110-001, 305-110-002, 305-110-003, 305-110-004, 305-110-005, 305-110-006, 305-110-015, 305-110-016, 305-110-021, 305-110-022, 305-110-023, 305-110-024, 305-110-025, 305-110-026, 305-110-027, 305-110-032, 305-110-033, 305-110-034, 305-110-035, 305-140-012, 305-140-024, 305-140-025, 305-140-026, 305-140-027, 305-140-034, 305-140-040, 305-140-052, 305-140-041, 305-140-053, 305-140-058, 305-140-059, 305-140-056, 305-140-057, 305-140-060, 305

IN THE CITY OF PERRIS, COUNTY OF RIVERSIDE, STATE OF CALIFORNIA  
**HARVEST LANDING RETAIL CENTER AND BUSINESS PARK**  
**TENTATIVE PARCEL MAP 38811**  
 INDEX SHEET

**LEGEND:**

— — — — — INDICATES PAGE DELINEATION

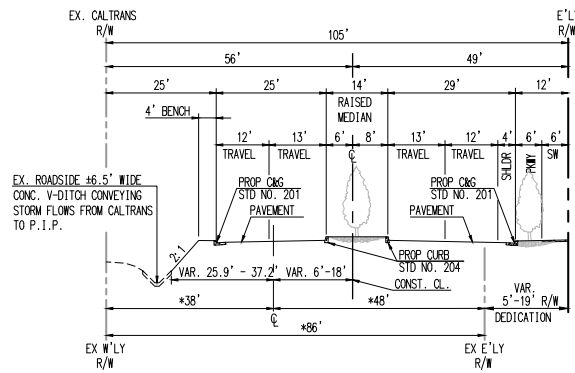
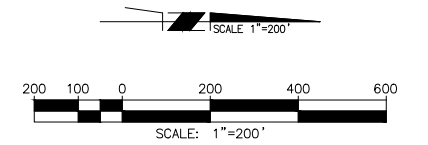

\*EXIST. DIMENSIONS FOR FRONTAGE SOUTH OF ORANGE AVE.  
**FRONTAGE ROAD**  
 (BARRETT AVE - ORANGE AVE)  
 SECONDARY ARTERIAL  
 (105'/68')

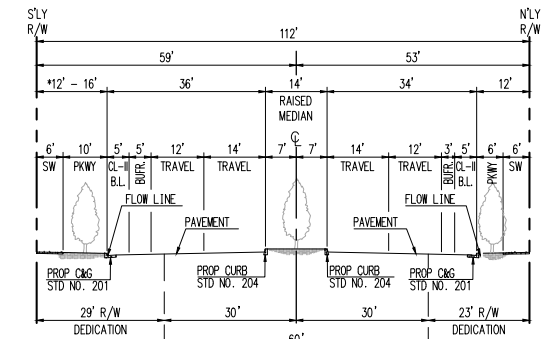

\* PROPOSED 12" MINIMUM DIMENSIONS FOR ALL RIGHT TURN POCKETS AT INTERSECTIONS  
**ORANGE AVENUE**  
 (BARRETT AVE - FRONTAGE RD)  
 SECONDARY ARTERIAL  
 (112'/84')

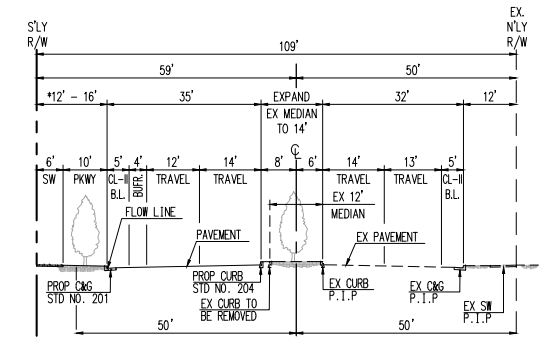

\* PROPOSED 12" MINIMUM DIMENSIONS FOR ALL RIGHT TURN POCKETS AT INTERSECTIONS  
**ORANGE AVENUE**  
 (PERRIS BLVD - BARRETT AVE)  
 SECONDARY ARTERIAL  
 (109'/81')

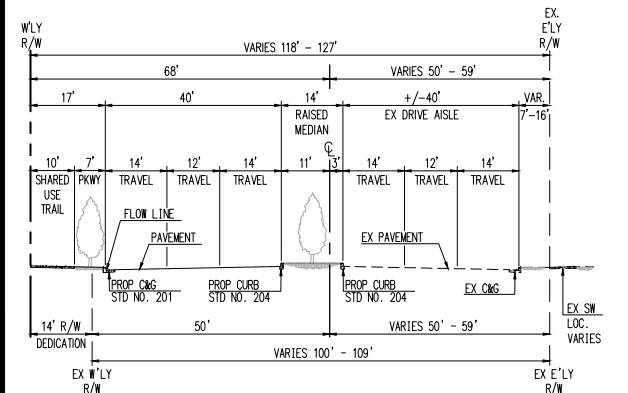

**PERRIS BOULEVARD**  
 PRIMARY ARTERIAL  
 (119'/90')

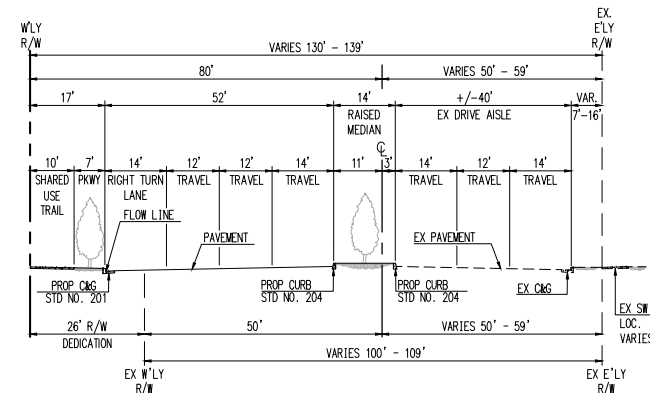

**EXPANDED PERRIS BOULEVARD**  
 PRIMARY ARTERIAL  
 (119'/90')

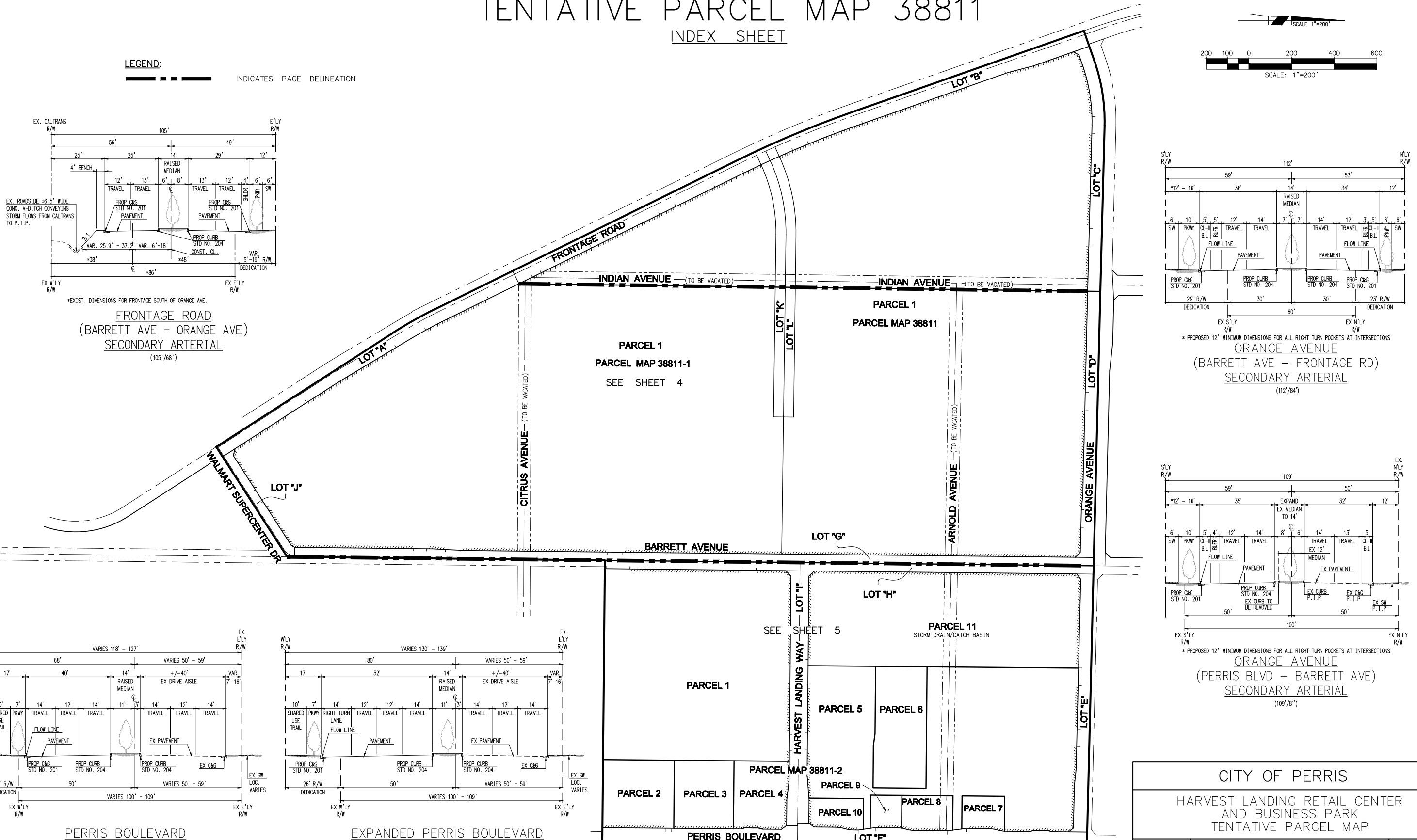

CITY OF PERRIS  
 HARVEST LANDING RETAIL CENTER  
 AND BUSINESS PARK  
 TENTATIVE PARCEL MAP

SCALE: AS SHOWN	DATE: JULY 2023	29995 TECHNOLOGY DRIVE, SUITE 306 MURRIETA   CA 92563 951.973.0201 - FMCIVIL.COM	SHEET
DESIGNED: DM	CHECKED: JD		<b>2</b>
PLN CK REF:			
			OF 5 SHEETS

H:\DATA\190210\CADD\MAPPING\PMAT - WESTING (GP\190210-TPM-002.DWG) ELISHA, GARRETT 1/27/2026 8:00 AM

IN THE CITY OF PERRIS, COUNTY OF RIVERSIDE, STATE OF CALIFORNIA  
 HARVEST LANDING RETAIL CENTER AND BUSINESS PARK  
 TENTATIVE PARCEL MAP 38811  
 PARCEL MAP 38811

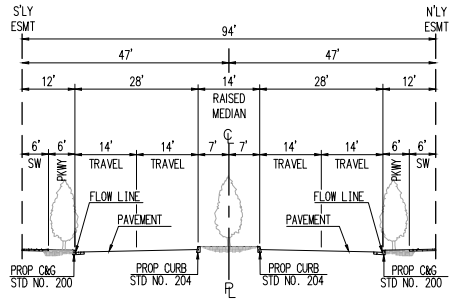

PRIVATE DRIVE "A"  
 SECONDARY ARTERIAL  
 (94/70')

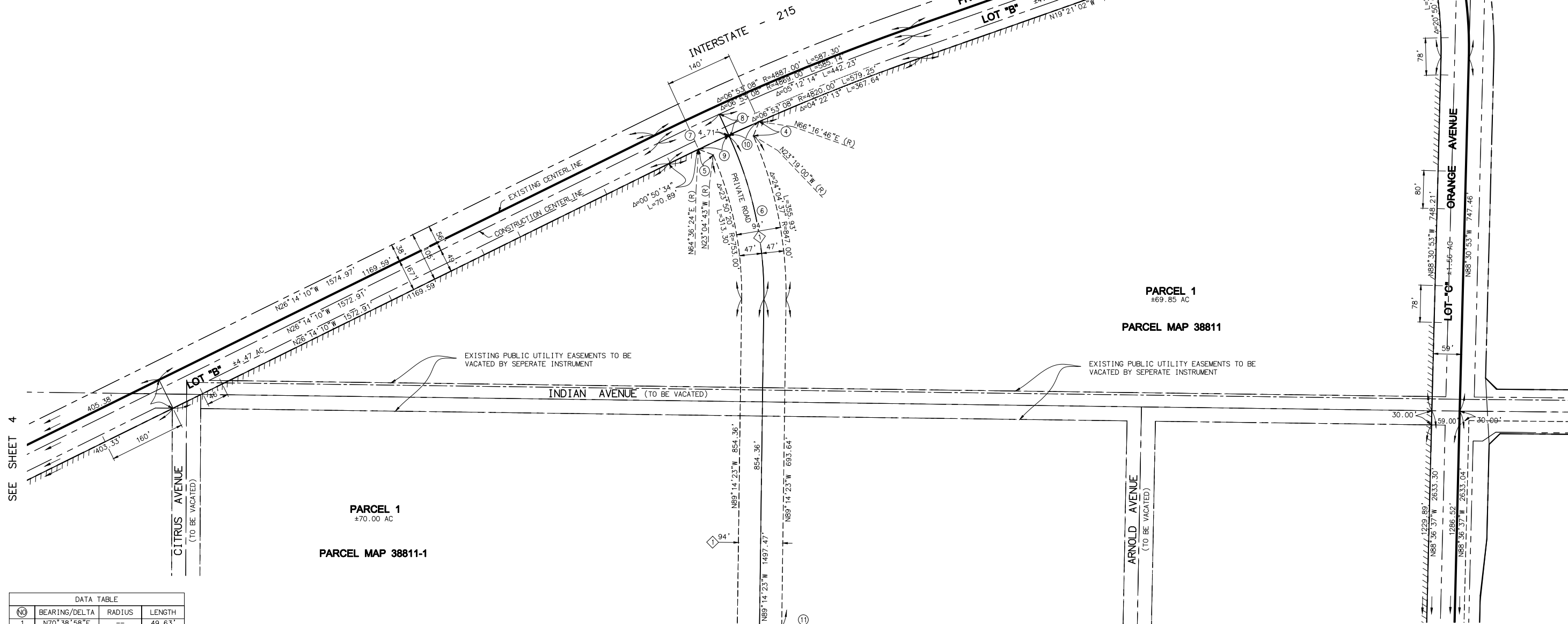

DATA TABLE

NO	BEARING/DELTA	RADIUS	LENGTH
1	N70°38'58"E	---	49.63'
2	N31°05'24"E	---	29.83'
3	N14°35'13"W	---	120.42'
4	N68°31'07"W	---	32.41'
5	N20°45'50"E	---	33.18'
6	25°18'53"	800.00'	353.46'
7	01°40'54"	4869.00'	142.91'
8	N65°26'44"E	---	53.71'
9	00°50'20"	4820.00'	70.58'
10	00°50'01"	4820.00'	70.13'
11	19°34'32"	100.00'	34.17'

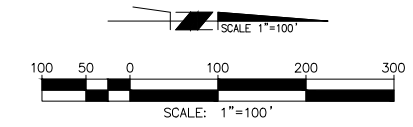

**LEGEND**  
 INDICATES RESTRICTED ACCESS  
 SEE NOTE 3 ON SHEET 1.

CITY OF PERRIS  
 HARVEST LANDING RETAIL CENTER  
 AND BUSINESS PARK  
 TENTATIVE PARCEL MAP

SCALE: AS SHOWN  
 DATE: JULY 2023  
 DESIGNED: DM  
 CHECKED: JD  
 PLN CK REF:

**FMCIVIL** ENGINEERS INC.  
 29995 TECHNOLOGY DRIVE, SUITE 306  
 MURRIETA | CA 92563  
 951.973.0201 - FMCIVIL.COM

SHEET  
**3**  
 OF 5 SHEETS

H:\DATA\180210\CADD\MAPPING\PM1 - WESTING\GP\180210-TPM-003.DWG ELLISH, GARRETT 1/29/2026 1:47 PM

IN THE CITY OF PERRIS, COUNTY OF RIVERSIDE, STATE OF CALIFORNIA  
**HARVEST LANDING RETAIL CENTER AND BUSINESS PARK**  
**TENTATIVE PARCEL MAP 38811**  
**PARCEL MAP 38811-1**

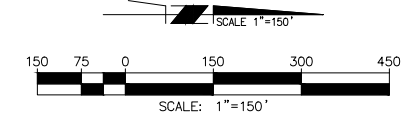
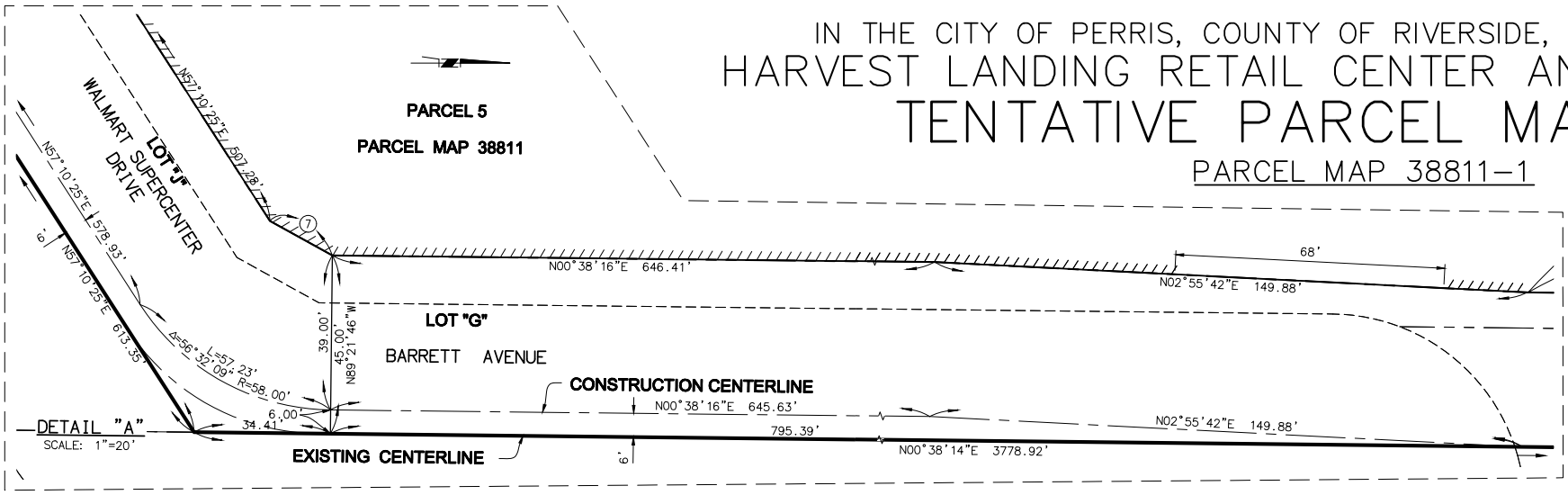

**LEGEND**  
 [Symbol] INDICATES RESTRICTED ACCESS  
 SEE NOTE 3 ON SHEET 1.

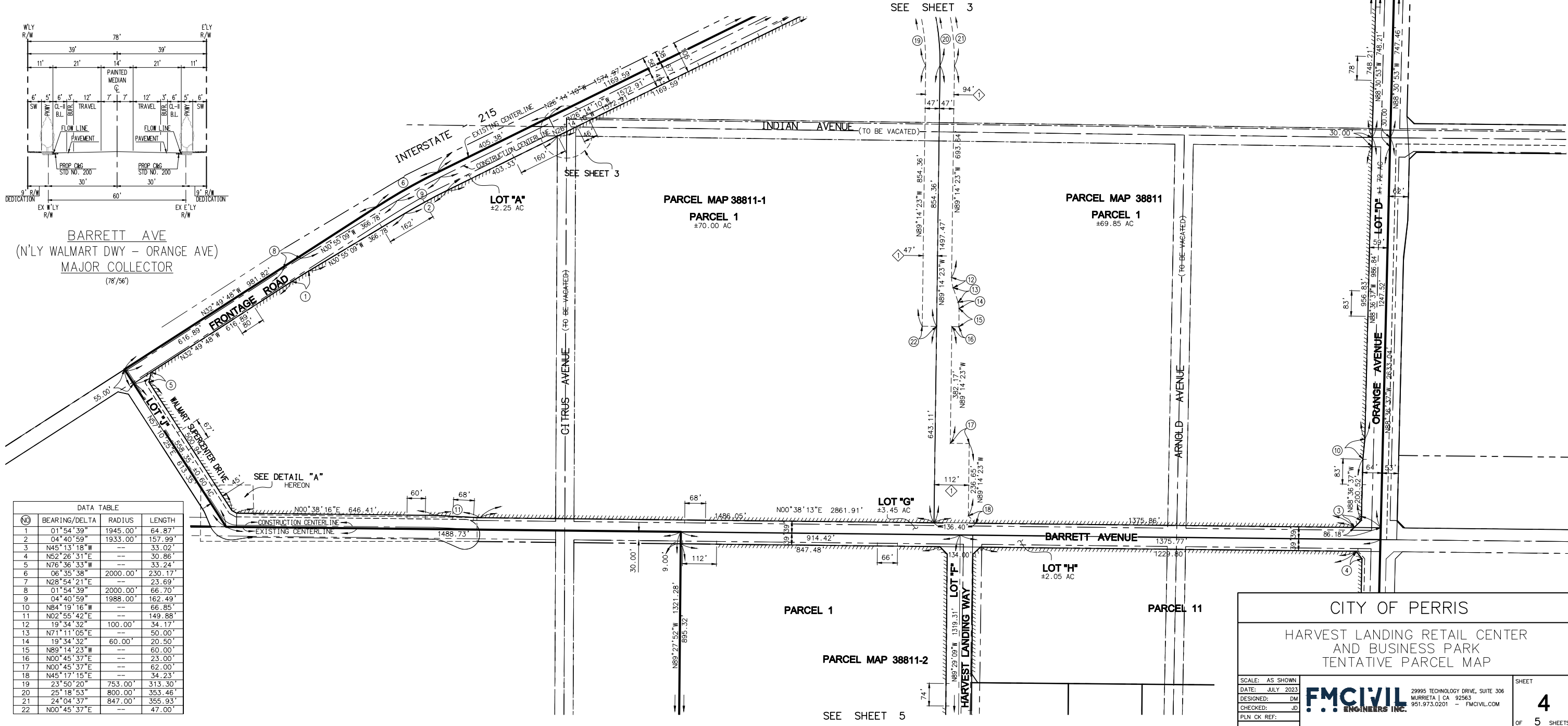
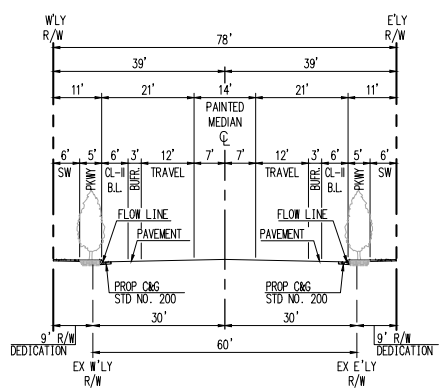
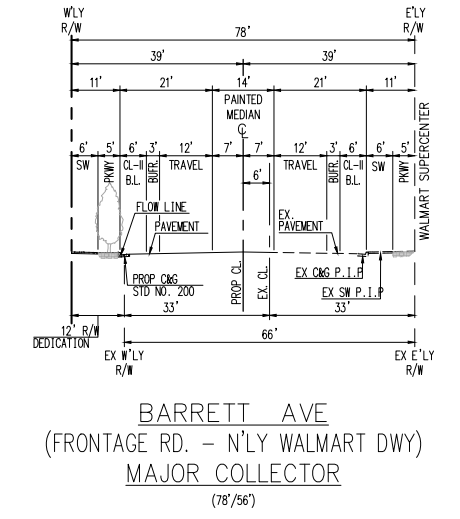

**DATA TABLE**

NO	BEARING/DELTA	RADIUS	LENGTH
1	01°54'39"	1945.00'	64.87'
2	04°40'59"	1933.00'	157.99'
3	N45°13'18"W	---	33.02'
4	N52°26'31"E	---	30.86'
5	N76°36'33"W	---	33.24'
6	06°35'38"	2000.00'	230.17'
7	N28°54'21"E	---	23.69'
8	01°54'39"	2000.00'	66.70'
9	04°40'59"	1988.00'	162.49'
10	N84°19'16"W	---	66.85'
11	N02°55'42"E	---	149.88'
12	19°34'32"	100.00'	34.17'
13	N71°11'05"E	---	50.00'
14	19°34'32"	60.00'	20.50'
15	N89°14'23"W	---	60.00'
16	N00°45'37"E	---	23.00'
17	N00°45'37"E	---	62.00'
18	N45°17'15"E	---	34.23'
19	23°50'20"	753.00'	313.30'
20	25°18'53"	800.00'	353.46'
21	24°04'37"	847.00'	355.93'
22	N00°45'37"E	---	47.00'

CITY OF PERRIS  
 HARVEST LANDING RETAIL CENTER  
 AND BUSINESS PARK  
 TENTATIVE PARCEL MAP

SCALE: AS SHOWN  
 DATE: JULY 2023  
 DESIGNED: DM  
 CHECKED: JD  
 PLN CK REF:

**F.M.CIVIL**  
 ENGINEERS INC.

29995 TECHNOLOGY DRIVE, SUITE 306  
 MURRIETA | CA 92563  
 951.973.0201 - F.M.CIVIL.COM

SHEET  
**4**  
 OF 5 SHEETS

H:\VPDATA\190210\CADD\MAPPING\190210-19M-04-DWG - ELLISH, GARRETT - 1/29/2026 1:50 PM



**GENERAL INFORMATION**

- 1) TOTAL GROSS ACREAGE 107.80 ACRES
- 2) EXISTING LAND USE VACANT PROPOSED LAND USE
- 3) PARCELS 1-7: INDUSTRIAL
- 4) EXISTING AND PROPOSED ZONING (HLS)P HARVEST LANDING SPECIFIC PLAN
- 5) ADJACENT LAND USE/ZONING LIGHT AGRICULTURE (A1), BUSINESS PARK (BP), COMMERCIAL COMMUNITY (CC)
- 6) THOMAS GUIDE - MAP PAGE 777
- 7) ALL STREETS WILL BE CONSTRUCTED PER CITY OF PERRIS STANDARDS AND REQUIREMENTS.
- 8) THIS MAP INCLUDES THE ENTIRE CONTIGUOUS OWNERSHIP OF THE LAND DIVIDER.

**FLOOD ZONE NOTE**

THE DESCRIBED PROPERTY IS DESIGNATED AS FEMA ZONE X, AREAS DETERMINED TO BE OUTSIDE THE 0.2% ANNUAL CHANCE FLOODPLAIN, AS SHOWN ON MAP PANEL 1430 OF 3805 AND 1440 OF 3805, MAP NO. 06065C1432H AND MAP NO. 06065C1440H, BOTH DATED 8/18/2014.

**AERIAL IMAGERY SOURCE**

INLAND AERIAL SURVEYS, DECEMBER 2022.

IN THE CITY OF PERRIS, COUNTY OF RIVERSIDE, STATE OF CALIFORNIA  
**TENTATIVE PARCEL MAP 38810**  
 HARVEST LANDING RETAIL CENTER AND BUSINESS PARK  
 (FOR FINANCE AND CONVEYANCE PURPOSES)

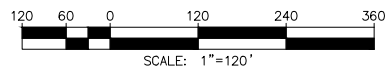

**OWNER/DEVELOPER**  
 HIP SO-CAL PROPERTIES, LLC  
 2244 N PACIFIC STREET  
 ORANGE, CA 92665  
 (TEL) 714-637-3333  
 CONTACT: TIMOTHY HOWARD

**SURVEYOR**  
 MICHAEL BAKER INTERNATIONAL  
 40810 COUNTY CENTER DR., SUITE 200  
 TEMECULA, CA 92591  
 (TEL) 951-676-8042  
 CONTACT: JOHN R. DUQUETTE, PLS

**ENGINEER**  
 FMCIVIL ENGINEERS, INC  
 29995 TECHNOLOGY DRIVE, SUITE 306  
 MURRIETA, CA 92563  
 (TEL) 951-973-0202  
 CONTACT: FRANCISCO MARTINEZ JR, PE

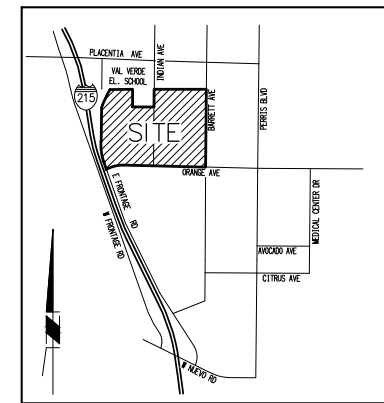

**VICINITY MAP**  
 T4S, R3W, SEC 19  
 NOT TO SCALE

**LEGAL DESCRIPTION**

THE BASIS OF THIS LEGAL DESCRIPTION IS A PRELIMINARY TITLE REPORT PREPARED BY FIRST AMERICAN TITLE COMPANY, UNDER ORDER NUMBER NS-1101318-0NT1 DATED NOVEMBER 23, 2021.

REAL PROPERTY IN THE CITY OF PERRIS, COUNTY OF RIVERSIDE, STATE OF CALIFORNIA, DESCRIBED AS FOLLOWS:

**PARCEL 1:** (305-070-004)  
 THE WEST HALF OF THE SOUTHEAST QUARTER OF SECTION 18, TOWNSHIP 4 SOUTH, RANGE 3 WEST, SAN BERNARDINO MERIDIAN, IN THE COUNTY OF RIVERSIDE, STATE OF CALIFORNIA.

EXCEPTING THEREFROM THE STREETS ON THE WESTERLY AND SOUTHERLY SIDES.  
 ALSO EXCEPTING THEREFROM THAT PORTION CONVEYED TO THE RIVERSIDE COUNTY TRANSPORTATION COMMISSION, A COUNTY TRANSPORTATION COMMISSION, A PUBLIC AGENCY OF THE STATE OF CALIFORNIA BY DOCUMENT RECORDED JULY 18, 2019 AS INSTRUMENT NO. 2019-02675320F OFFICIAL RECORDS OF RIVERSIDE COUNTY.

ALSO EXCEPTING THEREFROM THAT PORTION CONVEYED TO THE RIVERSIDE COUNTY TRANSPORTATION COMMISSION, A PUBLIC AGENCY OF THE STATE OF CALIFORNIA BY DOCUMENT RECORDED JULY 21, 2020 AS INSTRUMENT NO. 2020-0319073 OF OFFICIAL RECORDS OF RIVERSIDE COUNTY.

ALSO EXCEPTING THEREFROM AN UNDIVIDED ONE-HALF INTEREST IN AND TO ALL OIL, GAS, PETROLEUM, NAPHTHA, AND OTHER HYDRO-CARBON SUBSTANCES AND MINERALS OF WHATEVER KIND AND NATURE, IN AND UNDER THAT PORTION OF THE SOUTHEAST QUARTER OF SAID SECTION 18, HEREIN DESCRIBED AS RESERVED IN DEED FROM THE FEDERAL LAND BANK OF BERKELEY TO LOUIS B. MAYER, DATED DECEMBER 04, 1940 IN BOOK 487, PAGE 241 OF OFFICIAL RECORDS, RIVERSIDE COUNTY RECORDS.

**PARCEL 2:** (305-090-015, 305-090-016, 305-090-017, 305-090-019, 305-090-026, 305-090-028, 305-090-030, 305-090-032, 305-090-055, 305-090-056, 305-090-057, 305-090-058, 305-090-059)

BLOCKS 5 THROUGH 12, INCLUSIVE OF FIGADOTA FARMS NO. 14, AS SHOWN BY MAP ON FILE IN THE OFFICE OF THE COUNTY RECORDER OF THE COUNTY OF RIVERSIDE, STATE OF CALIFORNIA, IN BOOK 16, OF MAPS, PAGE 84 THEREOF.

EXCEPTING FROM BLOCK 12 THE SOUTH 212 FEET OF THE EAST 210 FEET.

ALSO EXCEPTING FROM BLOCKS 5 AND 9 DESCRIBED IN DEED TO THE STATE OF CALIFORNIA FOR A HIGHWAY, RECORDED JANUARY 23, 1952 IN BOOK 1336, PAGE 149, OFFICIAL RECORDS OF RIVERSIDE COUNTY, STATE OF CALIFORNIA.

ALSO EXCEPTING FROM BLOCKS 5 AND 9 DESCRIBED IN DEED TO THE STATE OF CALIFORNIA FOR A HIGHWAY, RECORDED APRIL 28, 1952 IN BOOK 1383, PAGE 432, OFFICIAL RECORDS OF RIVERSIDE COUNTY, STATE OF CALIFORNIA.

ALSO EXCEPTING FROM BLOCKS 5 AND 9 DESCRIBED IN FINAL ORDER OF CONDEMNATION TO THE STATE OF CALIFORNIA FOR A PUBLIC HIGHWAY, CASE NO. 206133, FILED NOVEMBER 10, 1994 IN SUPERIOR COURT OF THE STATE OF CALIFORNIA FOR THE COUNTY OF RIVERSIDE AND RECORDED NOVEMBER 28, 1994 AS INSTRUMENT NO. 19940044828 OFFICIAL RECORDS OF RIVERSIDE COUNTY, STATE OF CALIFORNIA.

ALSO EXCEPTING THEREFROM AN UNDIVIDED ONE-HALF INTEREST IN AND TO ALL OIL, GAS, PETROLEUM, NAPHTHA, AND OTHER HYDRO-CARBON SUBSTANCES AND MINERALS OF WHATEVER KIND AND NATURE, IN AND UNDER THAT PORTION OF THE SOUTHEAST QUARTER OF SAID SECTION 18, HEREIN DESCRIBED AS RESERVED IN DEED FROM THE FEDERAL LAND BANK OF BERKELEY TO LOUIS B. MAYER, DATED DECEMBER 04, 1940 IN BOOK 487, PAGE 241 OF OFFICIAL RECORDS, RIVERSIDE COUNTY RECORDS.

**PARCEL 8:** (305-060-042, 305-060-036, 305-060-037)  
 LOTS A, B, C, D, AND E IN BLOCK 1 AND LOTS A, B, C, AND D IN BLOCK 2 OF FIGADOTA FARMS NO. 14, IN THE CITY OF PERRIS, COUNTY OF RIVERSIDE, STATE OF CALIFORNIA AS PER MAP RECORDED ON FILE IN BOOK 16, PAGE 84 OF MAPS, IN THE OFFICE OF THE COUNTY RECORDER OF SAID COUNTY;

TOGETHER WITH THAT PORTION OF WATER STREET AND MCKIMBALL ROAD VACATED BY DOCUMENT RECORDED JUNE 10, 1952 IN BOOK 1375, PAGE 128, OF OFFICIAL RECORDS WHICH WOULD PASS BY OPERATION OF LAW WITH A LAND CONVEYANCE OF SAID LAND;

EXCEPTING THEREFROM THAT PORTION CONVEYED TO THE STATE OF CALIFORNIA BY DOCUMENT RECORDED MARCH 22, 1991 AS INSTRUMENT NO. 94569 OF OFFICIAL RECORDS OF RIVERSIDE COUNTY CALIFORNIA.

ALSO EXCEPTING THEREFROM THAT PORTION CONVEYED TO THE RIVERSIDE COUNTY TRANSPORTATION COMMISSION, A COUNTY TRANSPORTATION COMMISSION, A PUBLIC AGENCY OF THE STATE OF CALIFORNIA BY DOCUMENT RECORDED JULY 17, 2019 AS INSTRUMENT NO. 2019-0267531 OF OFFICIAL RECORDS OF RIVERSIDE COUNTY.

**BASIS OF BEARINGS**

THE BASIS OF BEARINGS FOR THIS SURVEY IS THE CALIFORNIA STATE PLANE COORDINATE SYSTEM, CCS83, ZONE 6, BASED LOCALLY ON CONTROL STATIONS "40 Y" AND "435" NAD83(NRS2007). ALL BEARINGS SHOWN ON THIS MAP ARE GRID, QUOTED BEARINGS AND DISTANCES FROM REFERENCE MAPS OR DEEDS ARE AS SHOWN PER THAT RECORD REFERENCE. ALL DISTANCES SHOWN DISTANCES SHOWN ARE GROUND DISTANCES UNLESS SPECIFIED OTHERWISE. GRID DISTANCES MAY BE OBTAINED BY MULTIPLYING THE GROUND DISTANCE BY A COMBINATION FACTOR OF 0.99992452. CALCULATIONS ARE MADE AT "40 Y" WITH COORDINATES OF: N2,245,643.330, E6,275,631.960, USING AN ELEVATION OF 1493.77'.

**ASSESSOR'S PARCEL NUMBERS:**

305-070-004, 305-090-015, 305-090-016, 305-090-017, 305-090-019, 305-090-026, 305-090-028, 305-090-030, 305-090-032, 305-090-055, 305-090-056, 305-090-057, 305-090-058, 305-090-059, 305-060-042, 305-060-036, 305-060-037

**UTILITIES**

<b>CABLE TELEVISION</b>	FRONTIER COMMUNICATIONS 22400 ALESSANDRO BOULEVARD MORENO VALLEY, CA 92553 (800) 801-6652	<b>TELEPHONE</b>	FRONTIER COMMUNICATIONS 22400 ALESSANDRO BOULEVARD MORENO VALLEY, CA 92553 (800) 801-6652
<b>ELECTRICITY</b>	SOUTHERN CALIFORNIA EDISON 26100 MENIFEE ROAD ROMOLAND, CA 92585 (800) 655-4555	<b>WATER AND SEWER</b>	EASTERN MUNICIPAL WATER DISTRICT 2270 TRUMBULE ROAD PERRIS, CA 92570 (951) 928-3777
<b>GAS</b>	SOUTHERN CALIFORNIA GAS COMPANY PO BOX 1626 MONTEREY PARK, CA 91754-8626 (800) 427-2000		



SEE SHEET 2

LOT 3  
SEE SHEET 3

**LEGEND:**  
 - - - - - INDICATES PAGE DELINEATION

**CITY OF PERRIS**  
 HARVEST LANDING RETAIL CENTER & BUSINESS PARK  
 TENTATIVE TRACT MAP EXHIBIT  
 FOR CONVEYANCE AND FINANCE PURPOSES

SCALE: AS SHOWN	<b>FMCIVIL</b> ENGINEERS INC.	29995 TECHNOLOGY DRIVE, SUITE 306 MURRIETA   CA 92563 951.973.0201 - FMCIVIL.COM	SHEET
DATE: JULY 2023			<b>1</b>
DESIGNED: DM			
CHECKED: JD			
PLN CK REF:			OF 3 SHEETS

H:\PDATA\190210\CADD\MAPPING\TMA2 - FINANCE & CONVEYANCE\CP\_190210-TMA-COOL.DWG - DUQUETTE, JOHN 11/17/2023 9:52 AM

IN THE CITY OF PERRIS, COUNTY OF RIVERSIDE, STATE OF CALIFORNIA  
**TENTATIVE PARCEL MAP 38810**  
 HARVEST LANDING RETAIL CENTER AND BUSINESS PARK  
 (FOR FINANCE AND CONVEYANCE PURPOSES)

(NO)	BEARING/Delta	RADIUS	LENGTH
1	02°02'17"	650.05'	23.12'
2	N01°35'01"E	--	60.00'
3	00°14'59"	600.05'	2.62'
4	N52°56'53"E	--	67.71'
5	N43°39'44"E	--	34.25'
6	N70°38'58"E	--	59.63'
7	N63°07'54"W	--	33.24'
8	N19°21'02"W	--	42.78'
9	N19°21'02"W	--	113.55'

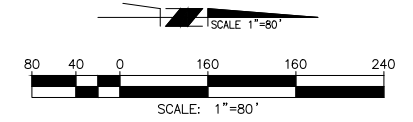

**LEGEND**  
 △ INDICATES WATER STREET VACATED PER DEED RECORDED JUNE 10, 1952, IN BOOK 1375, PAGE 128, O.R.

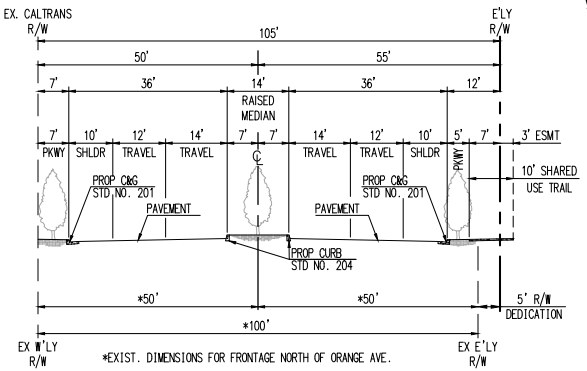
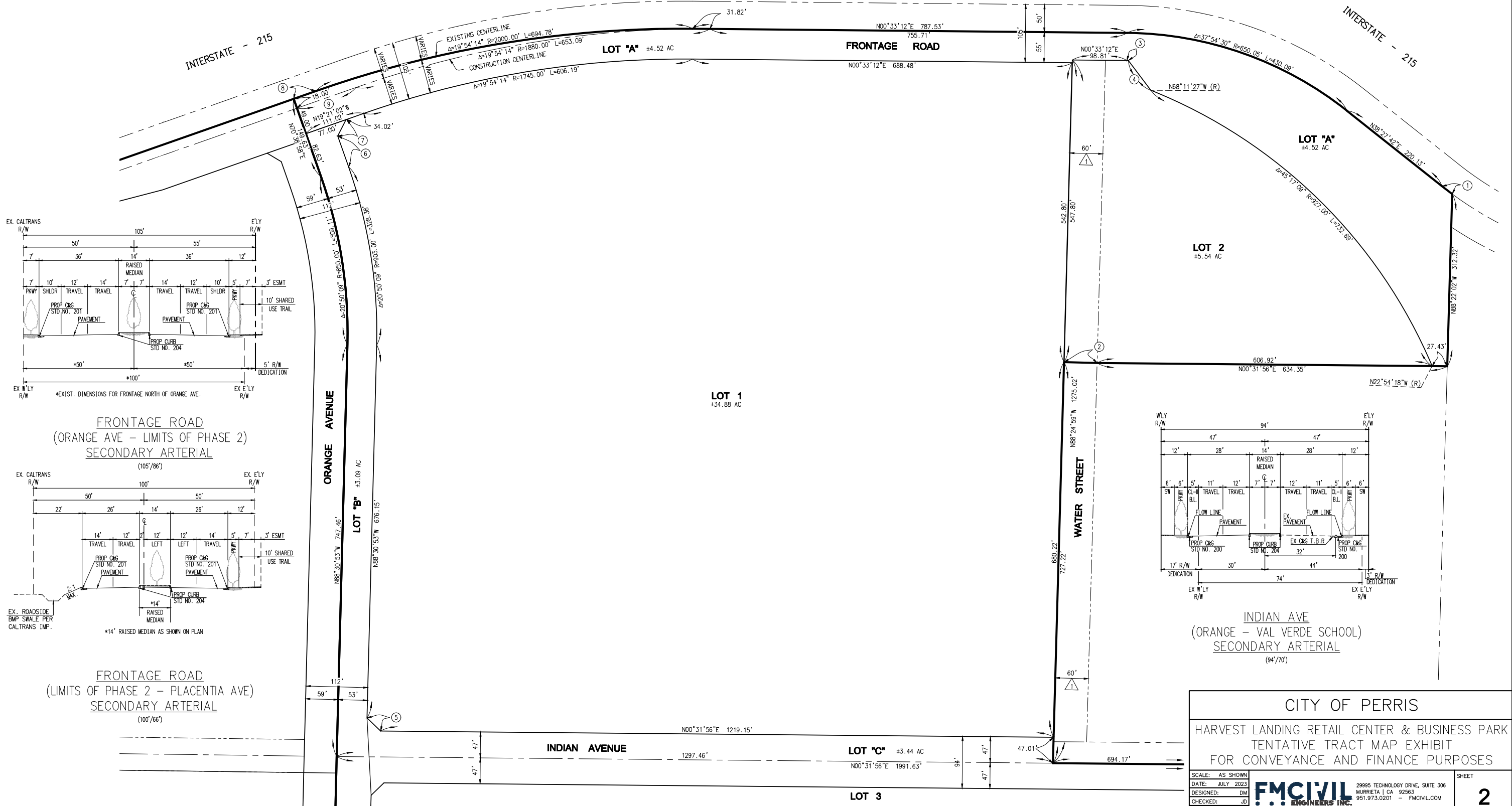

**FRONTAGE ROAD**  
 (ORANGE AVE - LIMITS OF PHASE 2)  
 SECONDARY ARTERIAL  
 (105/86)

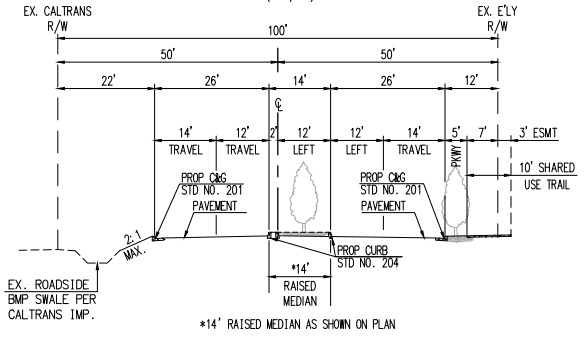

**FRONTAGE ROAD**  
 (LIMITS OF PHASE 2 - PLACENTIA AVE)  
 SECONDARY ARTERIAL  
 (100/66)

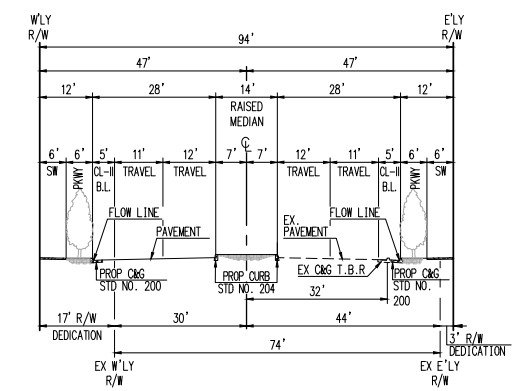

**INDIAN AVE**  
 (ORANGE - VAL VERDE SCHOOL)  
 SECONDARY ARTERIAL  
 (94/70)

**CITY OF PERRIS**

HARVEST LANDING RETAIL CENTER & BUSINESS PARK  
 TENTATIVE TRACT MAP EXHIBIT  
 FOR CONVEYANCE AND FINANCE PURPOSES

SCALE: AS SHOWN	DATE: JULY 2023	<b>FMCIVIL</b> ENGINEERS INC.	2995 TECHNOLOGY DRIVE, SUITE 306 MURRIETA   CA 92563 951.973.0201 - FMCIVIL.COM	SHEET
DESIGNED: DM	CHECKED: JD			<b>2</b>
PLN CK REF:				OF 3 SHEETS

SEE SHEET 3

P:\DATA\190210\CADD\MAPPING\TPM2 - FINANCE & CONVEYANCE\CP 3\190210-TPM-002.DWG - DUBUETTE, JOHN 11/17/2023 9:53 AM

IN THE CITY OF PERRIS, COUNTY OF RIVERSIDE, STATE OF CALIFORNIA  
**TENTATIVE PARCEL MAP 38810**  
 HARVEST LANDING RETAIL CENTER AND BUSINESS PARK  
 (FOR FINANCE AND CONVEYANCE PURPOSES)

DATA TABLE			
(NO)	BEARING/Delta	RADIUS	LENGTH
1	N44°51'32"E	---	34.94'
2	N25°00'22"E	---	27.46'
3	N83°50'48"W	---	132.46'
4	N88°36'37"W	---	200.50'
5	N86°56'35"E	---	140.35'
6	N44°02'20"W	---	32.28'

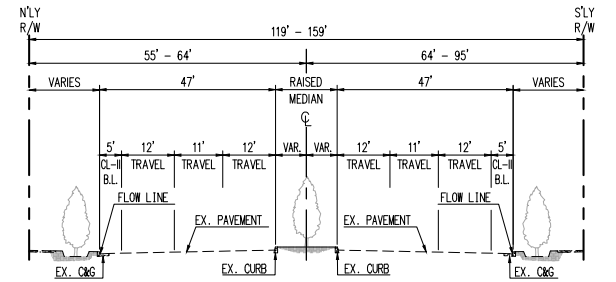

EXISTING SECTION PER APPROVED PLACENTIA AVENUE WIDENING PROJECT PB-1288  
**PLACENTIA AVENUE**  
**ARTERIAL**

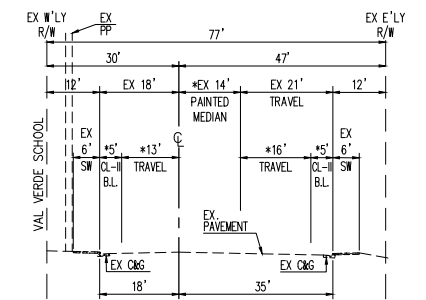

\* PROPOSED RE-STRIPING OF EXISTING ROADWAY  
**PROP INDIAN AVE**  
**(VAL VERDE SCHOOL - PLACENTIA AVE)**  
**SECONDARY ARTERIAL**  
 (74'/50')

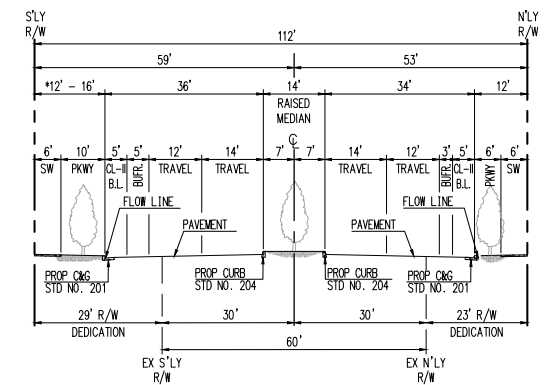

\* PROPOSED 12' MINIMUM DIMENSIONS FOR ALL RIGHT TURN POCKETS AT INTERSECTIONS  
**ORANGE AVENUE**  
**(BARRETT AVE - FRONTAGE RD)**  
**SECONDARY ARTERIAL**  
 (112'/84')

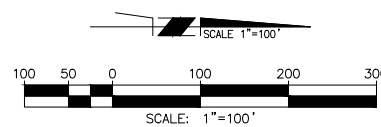
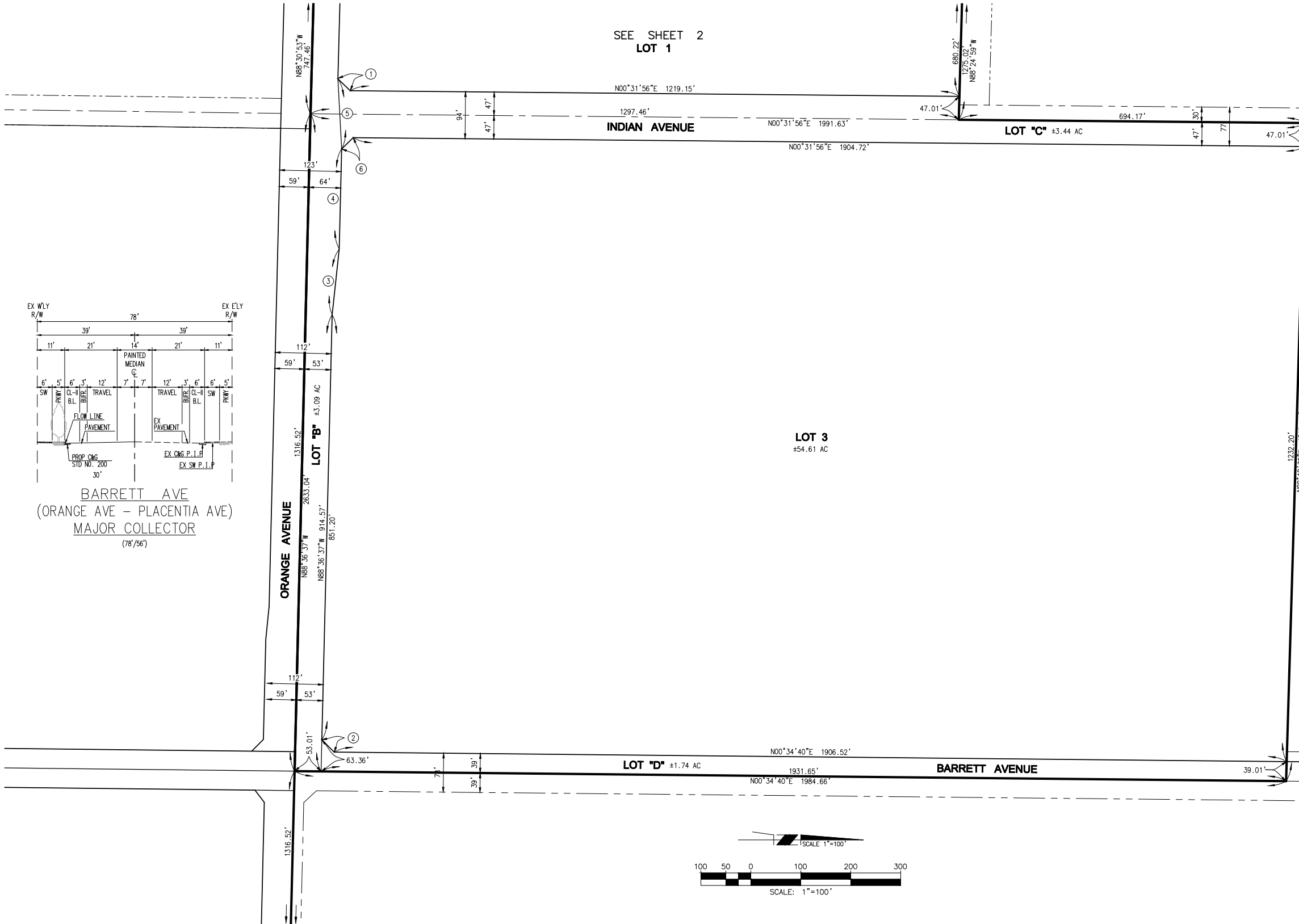

CITY OF PERRIS

HARVEST LANDING RETAIL CENTER & BUSINESS PARK  
 TENTATIVE TRACT MAP EXHIBIT  
 FOR CONVEYANCE AND FINANCE PURPOSES

SCALE: AS SHOWN	29995 TECHNOLOGY DRIVE, SUITE 306 MURRIETA, CA 92563 951.973.0201 - FMCIVIL.COM	SHEET
DATE: JULY 2023		<b>3</b>
DESIGNED: DM		
CHECKED: JD		
PLN CK REF:		OF 3 SHEETS

P:\DATA\190210\CADD\MAPPING\IPAV2 - FINANCE & CONVEYANCE\CP-3\190210-IPAV-003.DWG - DUQUETTE, JOHN 11/17/2023 11:29 AM

IN THE CITY OF PERRIS,  
COUNTY OF RIVERSIDE, STATE OF CALIFORNIA

# HARVEST LANDING RETAIL CENTER & BUSINESS PARK

## PROPOSED STREET SECTIONS

TENTATIVE PARCEL MAPS 38810 & 38811

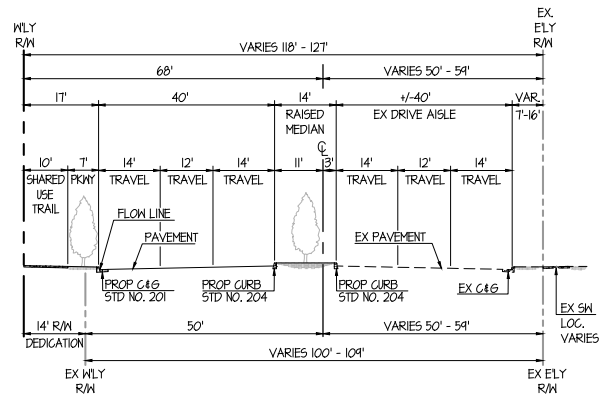

**PERRIS BOULEVARD**  
PRIMARY ARTERIAL  
(119/190)

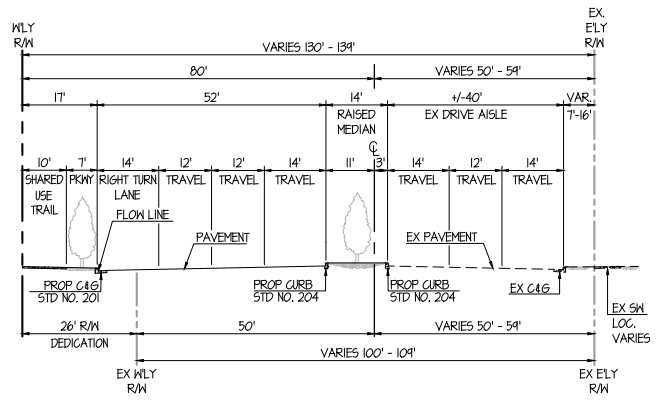

**EXPANDED PERRIS BOULEVARD**  
PRIMARY ARTERIAL  
(119/190)

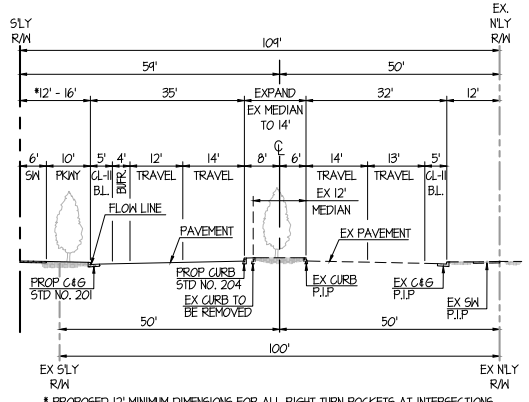

**ORANGE AVENUE**  
(PERRIS BLVD - BARRETT AVE)  
SECONDARY ARTERIAL  
(109/181)

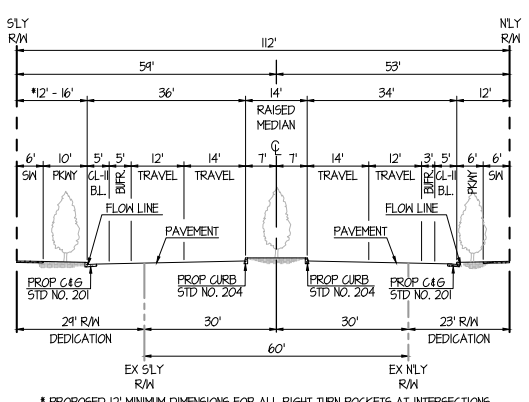

**ORANGE AVENUE**  
(BARRETT AVE - FRONTAGE RD)  
SECONDARY ARTERIAL  
(112/184)

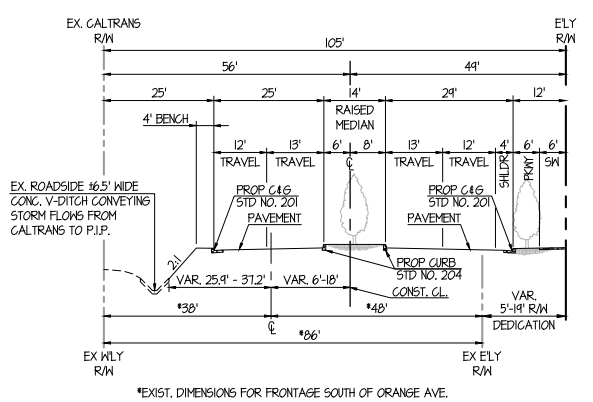

**FRONTAGE ROAD**  
(BARRETT AVE - ORANGE AVE)  
SECONDARY ARTERIAL  
(105/168)

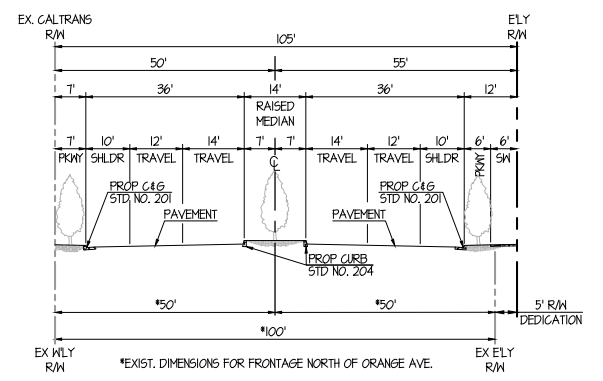

**FRONTAGE ROAD**  
(ORANGE AVE - LIMITS OF TPM 38810)  
SECONDARY ARTERIAL  
(105/166)

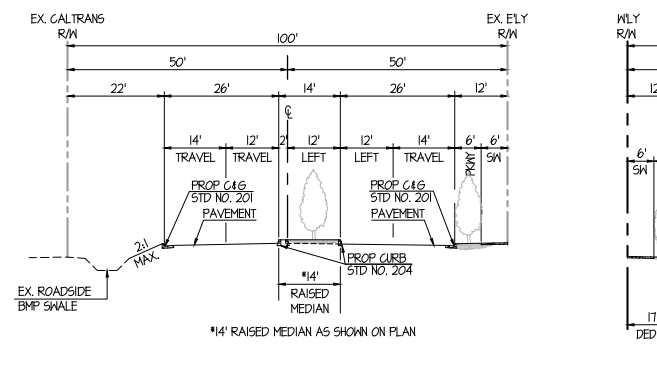

**FRONTAGE ROAD**  
(LIMITS OF TPM 38810 - PLACENTIA AVE)  
SECONDARY ARTERIAL  
(100/166)

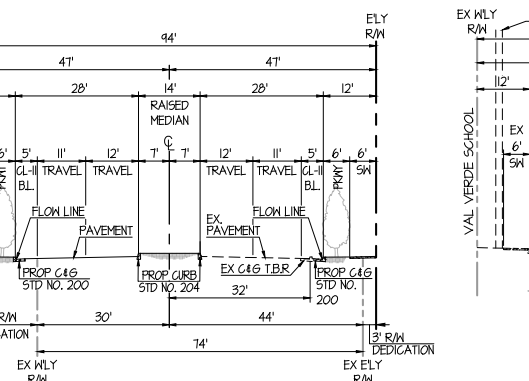

**INDIAN AVE**  
(ORANGE - VAL VERDE SCHOOL)  
SECONDARY ARTERIAL  
(94/170)

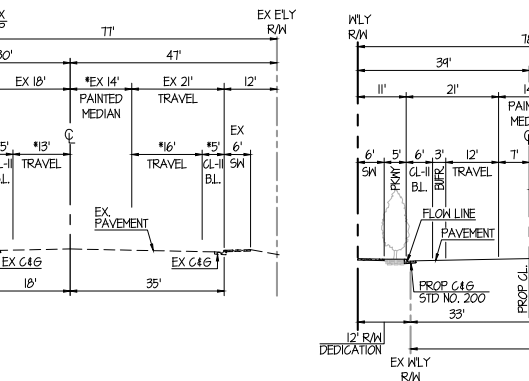

**PROP INDIAN AVE**  
(VAL VERDE SCHOOL - PLACENTIA AVE)  
SECONDARY ARTERIAL  
(14/150)

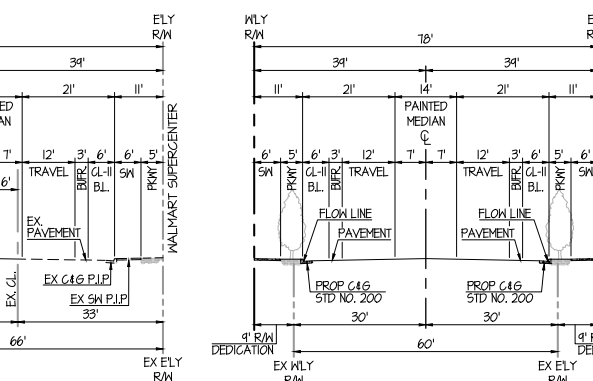

**BARRETT AVE**  
(FRONTAGE RD - N'LY WALMART DWY)  
MAJOR COLLECTOR  
(18/156)

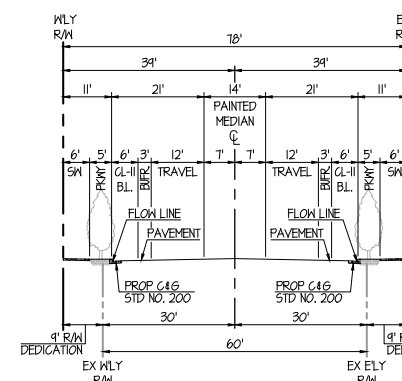

**BARRETT AVE**  
(N'LY WALMART DWY - ORANGE AVE)  
MAJOR COLLECTOR  
(18/156)

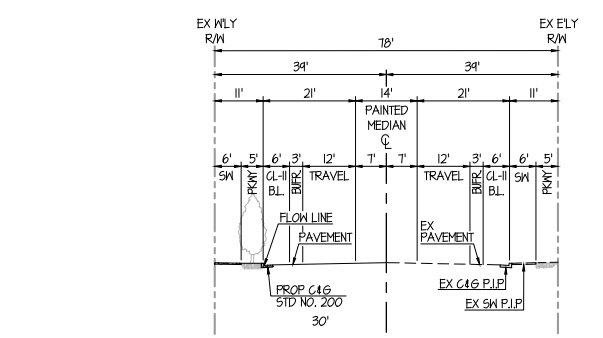

**BARRETT AVE**  
(ORANGE AVE - PLACENTIA AVE)  
MAJOR COLLECTOR  
(18/156)

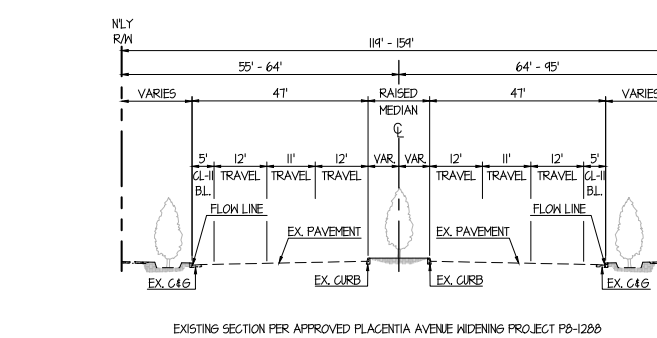

**PLACENTIA AVENUE**  
ARTERIAL  
EXISTING SECTION PER APPROVED PLACENTIA AVENUE WIDENING PROJECT P8-1288

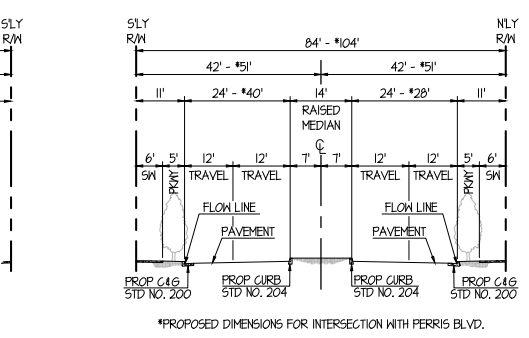

**HARVEST LANDING WAY**  
MODIFIED COLLECTOR  
(84/162)

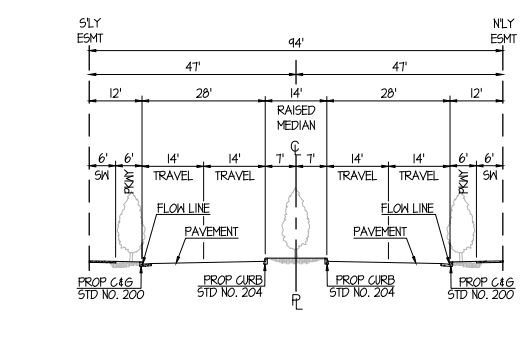

**PRIVATE DRIVE "A"**  
SECONDARY ARTERIAL  
(94/170)

**CITY OF PERRIS**

**HARVEST LANDING RETAIL CENTER & BUSINESS PARK**  
PROPOSED STREET SECTIONS  
TENTATIVE PARCEL MAP 38810 & 38811

SCALE: AS SHOWN	SHEET
DATE: JAN. 2026	1
DESIGNED: AJ	OF SHEETS
CHECKED: PM	
PLN. OR. REF:	

24445 TECHNOLOGY DRIVE, SUITE 306  
MARRIETTA, GA 30263  
951.913.0201 - FMCIVIL.COM

H:\PROJECTS\20-001-HARVEST LANDING\DWGS\PLANS\ENTIREMENT\EXHIBITS\20-001-EXH-05-PROP-ST-SECTIONS.DWG - ALLAN - 1/27/2026 10:23 AM