



CITY OF PERRIS

PLANNING COMMISSION

AGENDA SUBMITTAL

MEETING DATE: August 20, 2025

SUBJECT: General Plan Amendment 23-05247, Zone Change 23-05245, Planned Development Overlay Zone 23-05246, Tentative Tract Map 23-05244 (TTM 38775), and Development Plan Review 23-00019 *Continued from the May 7, 2025, Planning Commission meeting* – A proposal to consider the following entitlements to facilitate the construction of 141 townhome-style condominiums and amenities on 11.6 acres, located south of Nuevo Road and east of Wilson Avenue:

1. General Plan Amendment and Zone Change to change the land use designation of 11.6 acres from R-6,000 – Single-Family-Residential to MFR-14 – Multiple-Family-Residential;
2. Planned Development Overlay to allow flexibility from the MFR-14 development standards;
3. Tentative Tract Map to consolidate 57 parcels into one condominium lot and two lettered lots totaling 11.6 acres; and
4. Development Plan Review for review of the site plan and building elevations.

Applicant: Ryan Woosley, D.R. Horton

REQUESTED ACTION: Adopt Resolution No. 25-07 recommending that the City Council adopt Mitigated Negative Declaration No. 2403 and the Mitigation Monitoring and Reporting Program and approve General Plan Amendment (GPA) 23-05247, Zone Change (ZC) 23-05245, Planned Development Overlay (PDO) Zone 23-05246, Tentative Tract Map 23-05244 (TTM 38775), Development Plan Review (DPR) 23-00019 to facilitate the construction of 141 townhome-style condominiums and amenities on 11.6 acres, based on the findings contained in the Resolution and subject to the Conditions of Approval.

CONTACT: Patricia Brenes, Planning Manager

BACKGROUND

Planning Commission Meeting

On May 7, 2025, the Planning Commission unanimously continued off-calendar General Plan Amendment (GPA) 23-05247, Zone Change (ZC) 23-05245, Planned Development Overlay (PDO) Zone 23-05246, Tentative Tract Map 23-05244 (TTM 38775), Development Plan Review

(DPR) 23-00019 to facilitate the construction of 141 townhome-style condominiums and amenities on 11.6 acres, located south of Nuevo Road and east of Wilson Avenue.

The Planning Commission requested continuance to address the concerns noted below through an Ad Hoc meeting.

1. Inadequate landscaping along the easterly and southerly property lines.
2. Lack of accent materials and architectural detailing to differentiate Italianate from Spanish-style architecture.
3. Absence of a clubhouse in the site plan.
4. Insufficient on-site parking
5. Need for better communication with adjacent property owners.
6. Absence of 3-D renderings illustrating the main entrance and street views from Nuevo Road and Wilson Avenue.
7. Pending confirmation that all drive aisles comply with the minimum 24-foot-width required for emergency vehicle access.

In addition to the Commission's comments, four (4) Perris residents spoke in opposition to the Project during public testimony. Their concerns included the height of the existing stockpile on site and proximity to their homes, dust generated by grading activities, impacts on back yard privacy, and the likelihood of exacerbating on-street parking challenges associated with the apartment complex located directly north of the project site across Nuevo Road.

Ad-hoc Committee Meeting

On July 15, 2025, staff facilitated an Ad-Hoc Committee meeting for the project. During the meeting, the applicant presented updated architectural and site plan revisions, along with a proposed outreach strategy to engage adjacent property owners in response to previous concerns raised by the Planning Commission. While the Committee commended the overall improvements, they recommended the need for the following additional items:

1. Installation of a wrought iron gate and decorative tile band at the archway area of the pool building.
2. Inclusion of a 3-D street view rendering of the main entrance.
3. Modifications to the entry monument sign to ensure compatibility with the updated architectural style.
4. An updated parking exhibit consistent with the revised site plan.
5. Preparation of a community outreach flyer that includes a detailed project description.
6. Submission of a color and materials sample board for presentation at the planning commission hearing.

DISCUSSION

Project Modifications

In response to feedback from the Planning Commission, Ad Hoc Committee, and local residents, the applicant revised the project plans to address a range of design, operational, and neighborhood concerns.

Architecturally, the applicant incorporated several enhancements, including wrought iron pot shelves, decorative tile accents, stone veneer, and updated color schemes to better differentiate the Italianate style from the Spanish architectural style. The site plan was also modified to improve community amenities: the original 766-square-foot pool building was upgraded with an additional

735-square-foot meeting room connected via a breezeway; the pickleball courts were removed and replaced with two (2) additional parking spaces; the original dog park was removed to create expanded open space; and a new location for the dog park was identified elsewhere on the site.

To support a more comprehensive visual representation of the project, the applicant provided 3-D renderings of the main entrance, updated the entry monument signage for consistency with the revised architectural features, submitted a revised parking exhibit, and prepared a new color and materials board.

Response to Residents' Concerns

In addition to design revisions, the applicant also addressed several concerns raised by residents during the public hearing related to the stockpile, backyard privacy, and on street parking as follows:

- To mitigate issues related to the existing stockpile on-site, the applicant coordinated with the City Engineer's office to reduce its height and spread the dirt more evenly. Water trucks are being used regularly to control dust emissions, and the applicant has committed to removing the stockpile entirely by September 3, 2025.
- To address concerns about backyard privacy, especially from adjacent properties to the south and east, the applicant incorporated additional tree plantings and provided cross-section exhibits illustrating setbacks and visual buffers between the proposed development and neighboring homes.
- Lastly, regarding on-street parking impacts, the applicant indicated that project-specific CC&Rs will require residents to utilize their two-car garages for parking. Additionally, Nuevo Road will be striped with a Class II bike lane, accompanied by "No Parking" signage, to discourage overflow parking in the surrounding area.

Community Outreach

As part of the outreach efforts, the applicant indicated that 378 notices were mailed to residents and businesses within 500-foot radius of the project site, inviting them to a community meeting on July 23, 2025, at the Perris High School, Student Union Room, located at 175 E. Nuevo Road, which is the closes accessible venue to the project site. A total of eight (8) individuals attended the meeting.

According to the applicant, the project was presented to the residents and his team responded to questions and concerns raised by the attendees. They also provided details on their efforts to mitigate issues related to the on-site stockpile, including daily dust control through water truck spraying and a commitment to complete stockpile removal by September 3, 2025.

Based on the information provided, the applicant has made efforts to address both technical and community concerns.

ANALYSIS

Compliance With Applicable Development Standards

The revisions and additional information provided by the applicant have not changed the overall site plan layout, building height, and landscaping. Therefore, the project complies with the development standards of the MFR-14 Zone standards of the Perris Municipal Code, including lot standards, lot coverage, building height, setbacks, parking standards, and landscape coverage, as presented in the May 7, 2025, Planning Commission staff report (Exhibit H).

The parking table on the following page demonstrates how the project site exceeds the parking requirements outlined in Chapter 19.69 of the Municipal Code:

Chapter 19.69 - Parking Standards				
Requirements of Section 19.69.20 (B) and Section 19.59.040 (B.2.) General Regulations				
Use	Standard – Single Family	Required	Proposed	Consistency
Visitor Parking	0.3 – 0.5 Spaces per unit (141 units)	42 spaces	62 spaces	Consistent
Covered Parking	2 garage spaces/unit - 141 units	282 spaces	282 spaces	Consistent
Total Parking		324 spaces	344 spaces	Consistent
Total Surplus Parking		20 spaces		

PUBLIC HEARING NOTICE

A Notice of Public Hearing for the Planning Commission meeting was published in the local newspaper and sent to agencies and property owners within 300 feet of the project site. As of the writing of the staff report, staff has received no additional comments from surrounding property owners.

RECOMMENDATION

Adopt Resolution No. 25-07, recommending that the City Council adopt Mitigated Negative Declaration No. 2403 and the Mitigation Monitoring and Reporting Program and approve the Planned Development Overlay (PDO) Zone 23-05246, General Plan Amendment (GPA) 23-05247, Zone Change (ZC) 23-05245, Tentative Tract Map 23-05244 (TTM 38775), Development Plan Review (DPR) 23-00019 to facilitate the construction of 141 townhome-style condominiums and amenities on 11.6 acres based on the findings contained in the Resolution and subject to the Conditions of Approval.

BUDGET (or FISCAL) IMPACT: There is no fiscal impact associated with this Project since all project costs are borne by the applicant.

Prepared by: Nathan Perez, Senior Planner
 Reviewed by: Patricia Brenes, Planning Manager

EXHIBITS:

- A. Resolution 25-07 recommending adoption of the Mitigated Negative Declaration No. 2403 and the Mitigation Monitoring and Reporting Program and approval of the project with Conditions of Approval (Planning and Fire, Engineering, Public Works, Community Services, and Building & Safety)
- B. Location/Aerial Map
- C. Existing and Proposed General Plan Map
- D. Existing and Proposed Zoning Map (PDO Zone)
- E. MARB/IPA ALUCP Map
- F. Project Plans (Site Plan, Building Elevations, Renderings, Floor Plans,

Landscape Plans, and Wall/Fence Plans)

Due to the size of the files, Project Plans (Site Plan, Building Elevations, Renderings, Floor Plans, Landscape Plans, Wall and Fence Plans, Color and Material Sample Sheet, etc.) are available online at:

https://www.cityofperris.org/departments/development-services/planning/environmental-documents-for-public-review/-folder-517#docan1206_1313_479

G. Tentative Tract Map No. 38775

H. Planning Commission Staff Report Without Exhibits – Dated 5/7/2025.

Due to the size of the files, only the staff report is included as a hard copy. The staff report and exhibits are available online at:

https://www.cityofperris.org/departments/development-services/planning/environmental-documents-for-public-review/-folder-517#docan1206_1313_479

I. Applicant Prepared Outreach Letter (dated July 10, 2025)

J. Initial Study/Mitigated Negative Declaration and Associated Technical Studies.

Due to the size of the file, the documents are available online at:

https://www.cityofperris.org/departments/development-services/planning/environmental-documents-for-public-review/-folder-517#docan1206_1313_479

K. Notice of Public Hearing

Consent:

Public Hearing: X

Business Item:

Presentation:

Other:

Exhibit A

Resolution 25-07 recommending adoption of the Mitigated Negative Declaration No. 2403 and the Mitigation Monitoring and Reporting Program and approval of the project with Conditions of Approval (Planning and Fire, Engineering, Public Works, Community Services, and Building & Safety)

RESOLUTION NUMBER 25-07

A RESOLUTION OF THE PLANNING COMMISSION OF THE CITY OF PERRIS, COUNTY OF RIVERSIDE, STATE OF CALIFORNIA, RECOMMENDING THAT THE CITY COUNCIL ADOPT MITIGATED NEGATIVE DECLARATION NO. 2403 AND APPROVE GENERAL PLAN AMENDMENT (GPA) 23-05247, ZONE CHANGE (ZC) 23-05245, PLANNED DEVELOPMENT OVERLAY (PDO) ZONE 23-05246, TENTATIVE TRACT MAP (TTM) 23-05244 (TTM 38775) AND DEVELOPMENT PLAN REVIEW (DPR) 23-00019, FACILITATING THE CONSTRUCTION OF 141 TOWNHOME-STYLE CONDOMINIUMS AND ASSOCIATED AMENITIES ON 11.6 ACRES, GENERALLY LOCATED SOUTH OF NUEVO ROAD AND EAST OF WILSON AVENUE, BASED UPON THE FINDINGS PRESENTED HEREIN AND SUBJECT TO CONDITIONS OF APPROVAL.

WHEREAS, the project applicant, Ryan Woosley, D.R. Horton (“Applicant”), requests approval of the construction of 141 townhome-style condominiums and amenities including pickleball courts, a tot lot, a pool and pool house, and open space generally located at the southeast corner of Nuevo Road and Wilson Avenue, known as the Acacia Pointe; and

WHEREAS, the Applicant submitted an application for General Plan Amendment (“GPA”) 23-05247 and Zone Change (“ZC”) 23-05245 to change the land use designation of 11.6 acres from R-6,000 to MFR-14-Planned Development Overlay (MFR-14-PDO), Planned Development Overlay (“PDO”) 23-05246 to allow flexibility from the development standards, Tentative Tract Map 23-05244 (“TTM 38775”) for one condominium lot with two (2) lettered lots, Development Plan Review (“DPR”) 23-00019 for review of the site plan and building elevations; and

WHEREAS, the proposed GPA 23-05247, ZC 23-05245, PDO 23-05246, TTM 38775, and DPR 23-00019 are considered a “project” as defined by the California Environmental Quality Act (“CEQA”); and

WHEREAS, pursuant to CEQA and State CEQA Guidelines, an Initial Study (“IS”) was prepared for the proposed Project and, based upon review thereof by the City as lead agency, a Notice of Intent to Adopt a Mitigated Negative Declaration was issued in accordance with CEQA Guidelines Section 15072, and a Draft Mitigated Negative Declaration No. 2403 (“MND”) was prepared for the Project and was publicly reviewed for a thirty (30) day period in accordance with CEQA, from February 21, 2025, to March 24, 2025; and

WHEREAS, during the public comment period, three public comments were received. The public comments received during the public review period did not warrant or result in any “substantial revision,” within the meaning of CEQA Guidelines Section 15073.5,

to the MND. Although not required by CEQA, in the interests of thoroughness and transparency, responses to the public comments received have been prepared and included in the Final MND. No “substantial revision” of the MND has been made in response to the comments or otherwise, and therefore no recirculation is required pursuant to CEQA Guidelines Section 15073.5. No changes were made to the Draft MND in the Final MND. There is no substantial evidence in light of the whole record before the City, including the public comments received, that the project may have a significant effect on the environment which cannot be mitigated or avoided, and therefore no EIR is required pursuant to CEQA Guidelines Section 15073.5; and

WHEREAS, the Riverside County Airport Land Use Commission (“ALUC”) conducted a hearing on December 12, 2024, to consider the Project’s consistency with the D (Flight Corridor Buffer) Zone and determined that the Project is consistent with the March Air Reserve Base/Inland Port Airport (MARB/IPA) Land Use Compatibility Plan; and

WHEREAS, Chapter 19.54 (Authority and Review Procedures) of the City of Perris Municipal Code (“PMC”), authorizes the City to approve, conditionally approve, or deny requests for General Plan Amendments, Zone Changes, and Development Plan Reviews, PMC Chapters 18.12 and 18.16 authorize the City to review and approve, conditionally approve, or deny Tentative Tract Maps, and PMC Chapter 19.59 authorizes the City to review and approve or deny of a Planned Development Overlay; and

WHEREAS, a duly noticed Planning Commission public hearing was scheduled for May 7, 2025, and continued to the August 20, 2025, meeting, for the Project; and

WHEREAS, the Planning Commission held a duly noticed public hearing on August 20, 2025, at which time all interested persons were given full opportunity to be heard and to present evidence; and

WHEREAS, before acting, the Planning Commission has heard, been presented with, and reviewed all the information and data which constitutes the administrative record for the above-mentioned approvals, including all oral and written evidence presented to the City by members of the public and City staff during all Project meetings and hearings; and

WHEREAS, all other legal prerequisites to the adoption of this Resolution have occurred.

NOW, THEREFORE, THE PLANNING COMMISSION OF THE CITY OF PERRIS does resolve as follows:

Section 1. Recitals. The above recitals are all true and correct and are incorporated herein by this reference as findings of fact.

Section 2. CEQA Findings. The Planning Commission finds as follows with respect to the IS/MND for the Project:

- A. The Planning Commission has considered the whole administrative record, including

the IS/MND together with the comments received during the public review process and the responses thereto contained in the Final IS/MND. The Planning Commission has also considered whether the Project will result in a safety hazard or noise problem for persons using the March Air Reserve Base/Inland Port Airport or for persons residing or working in the Project area, and finds that it will not. The findings in this Section 2 are made on the basis of the whole administrative record.

- B. The IS/MND has been prepared and considered in compliance with CEQA and contains all required contents pursuant to CEQA Guidelines Section 15071.
- C. With the imposition of the mitigation measures set forth in the Mitigation Monitoring and Reporting Program (which is included in the IS/MND), there is no substantial evidence that the Project will have a significant effect on the environment. Said mitigation measures have been made enforceable conditions on the Project, as they have been included in the Project Conditions of Approval attached hereto as Attachment 1.
- D. The IS/MND reflects the independent judgment and analysis of the City.
- E. The location and custodian of the documents or other material which constitute the record of proceedings upon which the Planning Commission's decision set forth in this Resolution is based is as follows: City of Perris Planning Division, 135 N. D. St., Perris, CA 92570.

Section 3. General Plan Amendment 23-05247. The Planning Commission further finds, with respect to General Plan Amendment 23-05247, that:

- 1) *The General Plan Amendment is consistent with the General Plan Land Use Map and applicable General Plan objectives, policies, and programs.*

The proposed amendment will result in changing the General Plan land use designation from R-6,000 to MFR-14-PDO, which will create consistency with the proposed MFR-14-PDO Zone Change request. The proposed amendment would also create compatibility with the adjacent General Plan residential land use designations on the north, south and west. Further, changing the General Plan land use designation from R-6,000 to MFR-14-PDO aligns the property and General Plan land use designation with the direction of the community, which seeks to provide additional housing options to meet unmet housing demands and logically extends the existing zoning pattern to the north and east of the site.

Furthermore, the General Plan Amendment is consistent with General Plan Policy I. An of the General Plan Land Use Element, which seeks to promote variety in dwelling types, densities, and locations to satisfy changing demands as the community evolves and matures. It is also consistent with Goal 1 of the Housing Element, which seeks to promote and maintain various housing types for all economic segments of the City. Finally, as conditioned, the project meets or exceeds the objectives of the proposed MFR-14 General Plan land use designation and, as such, is consistent with the General Plan Land Use Map and applicable General Plan objectives, policies, and programs.

The proposed General Plan Amendment conforms to the goals of the General Plan as future development is conditioned to comply with Zoning Code development standards and provide for adequate services, infrastructure, and facilities, which implements the General Plan goals, objectives, and policies.

- 2) *The proposed amendment would not be detrimental to the public interest, health, safety, convenience, or welfare of the City.*

The proposed amendment will not be detrimental to the public interest, health, safety, convenience, or welfare of the City. The amendment to change the General Plan land use designation from R-6,000 to MFR-14-PDO will facilitate the development of residential development to meet demand in the City and regional housing demand, which is consistent with the General Plan goals and objectives. The site is located in an infill urbanized area surrounded by single-family residential on the north, west, south, and east with a similar residential density. Adequate site access and services are readily available, and future development will be required to adhere to all applicable city codes, standards, and policies, and thus, the amendment would not be detrimental to the public interest, health, safety, convenience, or welfare.

- 3) *In the case of an amendment to the General Plan Land Use Map, the subject parcel(s) is physically suitable (including, but not limited to access, provisions of utilities, compatibility with adjoining land uses, and absence of physical constraints) for the requested land use designation(s) and the anticipated land use development(s).*

The proposed General Plan Amendment will align the subject property with the proposed Zone Change, facilitating future residential development in a manner consistent with the existing neighborhood fabric, the General Plan's vision, and the City's Zoning Code. The parcel is physically suitable for townhome-style residential use, as it is of adequate shape and size, and utilities and city services are readily available to service the site. The property would gain access from the adjoining public roadway. The site is relatively flat and does not have any physical constraints, such as steep slopes or watercourses, to prevent future single-family development.

Section 4. Zone Change 23-05245. The Planning Commission further finds, with respect to Zone Change 23-05245, that:

- 1) *The proposed zoning is consistent with the General Plan Land Use Map and applicable General Plan objectives, policies and programs.*

The requested zone change from R-6,000 to MFR-14-PDO will be consistent with the proposed General Plan Land Use designation. The PDO will allow flexibility of development standards in exchange for superior amenities, site design, and architecture. The Acacia Pointe PDO project will provide a well-designed site plan, suitable vehicular access, and recreational opportunities at a density compatible with the existing surrounding residential uses. Furthermore, necessary water and sewer services are available to serve the site, and the development is required to comply with conditions, approval, and mitigation measures, which include paying its fair share and constructing transportation, drainage, and other improvements to serve the site.

The project is consistent with Housing Element Policy 1.2, which states, “Promote development within the City that provides a variety of housing types and densities based on the suitability of the land, including the availability of infrastructure, the provision of adequate services, and recognition of environmental constraints.” The project includes a townhome-style condo housing type. Therefore, the Project is consistent with the City’s General Plan and Zoning Ordinance.

2) *The proposed zoning is compatible with or provides adequate buffering of adjoining uses.*

As designed and through the application of the conditions of approval, the proposed project, the site is suitable for the proposed townhome-style condominium development. Additionally, the proposed project is compatible with the existing adjoining land uses, which consist residential neighborhoods, in terms of density, zoning, and product type. Therefore, the proposed subdivision is compatible with surrounding land uses and zoning designations.

3) *The proposed zoning is a logical extension of the existing zoning pattern.*

The proposed MFR-14-PDO zoning is a logical extension of the existing approved zoning pattern, immediately west and south of the site, which is zoned as MFR-14, MFR-22 zoning to the north, as well as surrounding residential uses to the east, designated as R-10,000. Overall, the proposed zoning will be a logical extension of the existing residential zoning pattern. The proposed zoning would also facilitate the development of more affordable, smaller-lot residential housing to address unmet market demand in the City and regional areas.

Section 5. Planned Development Overlay Zone 23-05246. The Planning Commission further finds, with respect to Planned Development Overlay 23-05246, that:

1) *The proposed project is a group of lots having a total area of at least two acres, but not more than 75 acres, and the land on which the planned unit overlay is applied is contiguous and under the development control of the applicant.*

The Project site is 11.6 acres in size, which is larger than the minimum of 2 acres and less than the maximum of 75 acres. Further, the Project site is contiguous and is under the development control of the Applicant.

2) *The proposed project is well designed and will create a superior environment than could otherwise be achieved by strict application of the underlying conventional zone.*

The proposed Project will create superior environment by covered outdoor picnic seating areas, cornhole courts, dog park, a tot-lot play area, a community pool with spa, and a 1,669-square-foot clubhouse building distributed throughout the development. Also, the project proposes a well-designed, superior environment with safe pedestrian connections to recreational amenities and public right of way that otherwise could not be achieved by strict application of a conventional zone, and four-sided architecture featuring elements characteristic of Spanish and Italianate style.

Also, the project will propose a perimeter gate that will provide control point of access for security not allowed through a conventional residential zone. The PDO designation assures the creation of a Homeowners Association (HOA) that will be required to maintain these open spaces and recreation areas in perpetuity, which will maintain the private streets within the gated community.

3) *The project incorporates appropriate amenities necessary to create and maintain a desirable environment for residents and/or employees.*

The proposed Project includes several recreational amenities, such as a clubhouse, swimming pool, and spa, pool building, children's play area/tot lot, picnic shelters, cornhole courts, and a dog park. The proposed town-home-style units will be designed to meet the standards outlined in the City's Residential Design Guidelines and will include various architectural enhancements for each product design.

4) *The proposed planned development is harmonious with surrounding development and does not create internal incompatibilities due to improper design, allowed land uses, or density/intensity of development.*

The Project location is surrounded by existing residential neighborhoods to the south, west, and east, which makes this residential Project harmonious with surrounding development. The project have similar lot sizes and dwelling unit densities to the surrounding neighborhoods to the west, south, and east.

5) *The proposed circulation system is adequate to carry the anticipated traffic volume.*

The proposed circulation system utilizes existing streets surrounding the Project site, including street improvements designed to assist with circulation around the site and within the existing neighborhood. Also, the internal circulation system is proposed to carry the anticipated traffic volume of the gated community. The proposed circulation system, including the street improvements, will be adequate to carry the anticipated traffic volume.

6) *The existing or proposed public infrastructure is suitable to meet the needs of the planned development and does not create capacity issues in other areas of the community.*

The proposed Project includes extending all improvements and associated services required for the property's development and improving Nuevo Road and Wilson Avenue to the ultimate street widths necessary to improve public infrastructure. Therefore, the public infrastructure is well-suited to meet the needs of the planned development.

Section 6. Tentative Tract Map 23-05244 (TTM 38775). The Planning Commission further finds, with respect to Tentative Tract Map 23-05244 (TTM 38775), that:

1. *The proposed map is consistent with the applicable General Plan and Specific Plans.*

The design and improvements required for the Project are consistent with the City General Plan and MFR-14 Zone. The Project will provide adequate vehicular access and recreational opportunities at a density compatible with the existing surrounding residential uses. Furthermore, necessary water and sewer services are available to serve the site, and the development is required to comply with conditions, approval, and mitigation measures, which include paying its fair share and constructing transportation, drainage, and other improvements to serve the site. Therefore, the proposed Tentative Tract Map is consistent with the City's General Plan, and Zoning Code.

2. *The design and improvement of the proposed subdivision is consistent with the applicable General Plan and Specific Plans.*

The project is not within a Specific Plan Area. The proposed subdivision is consistent with the applicable General Plan Circulation Plan, Housing Element, and Safety Element policies outlined below:

- Safety Element:

Policy S-2.1 – Require road upgrades as part of new developments/major remodels to ensure adequate evacuation and emergency vehicle access. Limit improvements for existing building sites to property frontages.

- Circulation Element:

Policy IV.A - Provide non-motorized alternatives for commuter travel as well as recreational opportunities that maximize safety and minimize potential conflicts with pedestrians and motor vehicles.

- Housing Element:

Policy 1.2: - Promote development within the City that provides a variety of housing types and densities based on the suitability of the land, including the availability of infrastructure, the provision of adequate services, and recognition of environmental constraints

3. *The site is physically suitable for the type of development.*

The site is physically suitable for residential development since it was previously graded as a single-family conventional subdivision which graded the site, and is surrounded by residential neighborhoods to the south, east and west.

4. *The site is physically suitable for the proposed density of the development.*

As noted above, the project is physically suitable for the density of the proposed townhome condominium community. The Project has been designed to be consistent with all applicable City Code requirements through the application of the Planned Development Overlay Zone to the proposed MFR-14 Zone. Furthermore, the project complies with required amenities, landscaping, and parking standards, as noted in the staff report.

5. *The design of the subdivision and the proposed improvements will not cause substantial environmental damage or substantially and avoidably injure fish or wildlife or their habitat.*

The potential environmental impacts associated with the Project were evaluated in the IS/MND, and it has been determined that with the incorporation of the mitigation measures which are included as enforceable conditions of approval, the Project will not cause any significant impacts on biological resources.

6. *The design of the subdivision and the type of improvements will not cause serious public health problems.*

An IS/MND has been completed in compliance with the California Environmental Quality Act (CEQA) Guidelines. The IS/MND concluded that the Project will not cause significant human health or cancer risk to sensitive receptors.

7. *The design of the subdivision and the proposed improvements will not conflict with easements of record or easements established by court judgment, acquired by the public at large, for access through or use of, property within the proposed subdivision.*

The design of the subdivision or any type of improvements will not conflict with easements of record or easements established by court judgment, acquired by the public at large, for access through or use of property within the proposed subdivision.

8. *All requirements of CEQA have been met.*

As mentioned above, an IS/MND has been prepared to comply with the California Environmental Quality Act (CEQA) Guidelines. Therefore, all requirements of CEQA have been met.

9. *The discharge of waste from the proposed subdivision into an existing community sewer system would not result in violation of existing requirements prescribed by a state regional water quality control board pursuant to division 7 (commencing with section 13000) of the Water Code.*

The development is required to comply with all provisions of City of Perris Ordinance Number 1194, which establishes stormwater and urban runoff management and discharge controls to improve water quality and comply with federal regulations, as well as any subsequent amendments, revisions, or ordinances pertaining thereto. Therefore, a Pre-WQMP (Water Quality Management Plan) has been prepared. The structural BMPs selected for this project have been approved in concept. The owner is required to submit a final WQMP including plans and details providing the elevations, slopes, and other details for the proposed structural BMPs, including three Modular Wetlands Systems, self-retaining landscape, and covered trash enclosures. The Public Works department shall review and approve the final WQMP text, plans,

and details. Therefore, the project will comply with the requirements of the Santa Ana Water Quality Control Board.

Section 7. Development Plan Review 23-00019. The Planning Commission further finds, with respect to Development Plan Review 23-00019, that:

- 1) *The location, size, design, density, and intensity of the proposed development and improvements are consistent with the City's General Plan, and the development policies and standards of the City.*

The General Plan designation and MFR-14 Zone provides for duplexes, townhomes, and single-family detached residential development at a density of 14 dwelling units per acre. The PDO further allows a 10% density bonus based on the underlying zone. The Project, as designed, proposes 13.7 units per acre, which supports residential development by allowing smaller lots than normally associated with a typical MFR-14-PDO subdivision. The proposed Project is consistent with the General Plan, the MFR-14 zone and PDO requirements, and the existing land uses in the area, which is located in Planning Area 4 of the City's General Plan. The project will also be constructed in compliance with the requested Planned Development Overlay Zone standards. Additionally, the Project is consistent with the City's Residential Design Guidelines adopted on September 6, 2023, including consistency with Chapter 2 (General Design Guidelines), Chapter 3 (Single Family Design Guidelines), and Chapter 7 (Architectural Style Guidelines). The location, size, design, density, and intensity of the proposed development and improvements are consistent with the City's General Plan, the MFR-14-PDO Zone, and provisions of the Perris Municipal Code.

- 2) *The proposed Project site is physically suitable, including, but not limited to, parcel size, shape, access, and availability of utilities and services, for the type of development proposed.*

The proposed Project is physically suitable in terms of parcel size, shape, access, and availability of utilities and services. The site is located south of Nuevo Road and east of Wilson Avenue, which allows for adequate access and provides a logical connection to infrastructure to service the site. Utility services such as water and sewer are adjacent to the Project and are available to service the site.

- 3) *The proposed development and the conditions under which it would be operated or maintained is compatible with abutting properties and will not be detrimental to the public health, safety or welfare or materially injurious to properties or improvements in the vicinity.*

As conditioned, the proposed Project will not be detrimental to the public health, safety or welfare or injurious to property and improvements in the vicinity or to the City's general welfare in that the Project is designed in conformance with the General Plan and the City's Residential Design Guidelines. Therefore, the Project will not be detrimental to the public health, safety, or welfare or materially injurious to properties or improvements in the vicinity. These standards include setbacks, building height, parking, and landscape and will integrate into the existing

fabric of residential development contemplated for the area.

- 4) *The architecture proposed is consistent with community standards and protects the character of adjacent development.*

The proposed architecture meets the City's design standards for single-family residential development, thereby protecting the character of the MFR-14 Zone; therefore, it is compatible with community standards and protects the character of adjacent development. Also, the PDO requires superior architecture in exchange for flexibility in development standards. Enhanced architecture, site design, and landscaping have been provided for the Project. The Project proposes using high-quality materials for each product type, including stucco finishes, stacked stone, and shutters. The proposed color palette and materials offer a range of interest, utilizing color tones that transition from light to dark accents to enhance the proposed residential buildings.

- 5) *The landscaping plan ensures visual relief and provides an attractive environment for the public's enjoyment.*

The proposed Project includes 30% onsite landscape coverage including recreational areas landscaping, on-site perimeter landscaping along both roadways, entrance landscaping. Plant materials include a mix of native and drought-tolerant trees, shrubs, ground cover, and annual color throughout the site to ensure visual relief and effectively frame, soften, and embellish access points, building entries, and open space areas. All trees proposed for the development include 36-inch box-sized street trees and 24-inch box-sized trees.

- 6) *The safeguards necessary to protect public health, safety, and general welfare have been required for the proposed Project.*

The proposed Project provides the safeguards necessary to protect the public health, safety, and general welfare through the conditions of approval, which are attached hereto and incorporated herein by this reference as Attachment 1, and mitigation measures found in Mitigated Negative Declaration No. 2403, which are incorporated herein by this reference, which will ensure that the Project is developed in compliance with City and affected service agency codes and policies and mitigates potential impacts to the environment.

Section 8. Based upon the preceding and all oral and written statements and reports presented by City staff and members of the public, including, but not limited to, all such statements and reports (including all attachments and exhibits) presented at its public hearing on August 20, 2025, the Planning Commission recommends the City Council adopt Mitigated Negative Declaration No. 2403 and the included MMRP attached to this Resolution as Attachment 2 and incorporated herein by this reference.

Section 9. Based upon the preceding and Mitigated Negative Declaration No. 2403, and all oral and written communication submitted by members of the public and City staff, including, but not limited to, all such statements and reports (including all attachments and exhibits) presented at its public hearing on August 20, 2025, the Planning Commission

hereby recommends the City Council approve General Plan Amendment (GPA) 23-05247, Zone Change (ZC) 23-05245, Planned Development Overlay (PDO) 23-05246, Tentative Tract Map 23-05244 (TTM 38775), Development Plan Review (DPR) 23-00019, subject to the Conditions of Approval attached to this Resolution as Attachment 1 and incorporated herein by this reference.

Section 10. The Planning Commission declares that should any provision, section, paragraph, sentence, or word of this Resolution be rendered or declared invalid by any court of competent jurisdiction or by reason of any preemptive legislation, the remaining provisions, sections, paragraphs, sentences, and words of this Resolution shall remain in full force and effect.

Section 11. The Chairperson shall sign this Resolution, and the Secretary shall certify adoption of this Resolution.

ADOPTED, SIGNED, and APPROVED this 20th day of August 2025.

CHAIRPERSON, PLANNING COMMISSION

ATTEST:

Secretary, Planning Commission

STATE OF CALIFORNIA)
COUNTY OF RIVERSIDE) §
CITY OF PERRIS)

I, Patricia Brenes, SECRETARY OF THE PLANNING COMMISSION OF THE CITY OF PERRIS, DO HEREBY CERTIFY that the foregoing Resolution Number 25-07 was duly adopted by the Planning Commission of the City of Perris at a regular meeting of said Planning Commission on the 20th day of August 2025, and that it was so adopted by the following vote:

AYES:
NOES:
ABSTAIN:
ABSENT:

Secretary, Planning Commission

Attachments:

1. Conditions of Approval (Planning and Fire, Engineering, Public Works, Community Services, and Building & Safety).
2. Mitigated Negative Declaration No. 2403
Due to the size of the files, the documents are available online at:
https://www.cityofperris.org/departments/development-services/planning/environmental-documents-for-public-review/-folder-517#docan1206_1313_479

**CITY OF PERRIS
DEVELOPMENT SERVICES DEPARTMENT
PLANNING DIVISION**

RECOMMENDED CONDITIONS OF APPROVAL

General Plan Amendment (GPA) 23-05247

Zone Change (ZC) 23-05245

Planned Development Overlay (PDO) Zone 23-05246

Tentative Tract Map 23-05244 (TTM 38775)

Development Plan Review (DPR) 23-00019

August 20, 2025

General Plan Amendment (GPA) 23-05247, Zone Change (ZC) 23-05245, Planned Development Overlay (PDO) Zone 23-05246, Tentative Tract Map 23-05244 (TTM 38775), Development Plan Review (DPR) 23-00019 – A proposal to consider the following entitlements to facilitate the construction of 141 townhome-style condominiums and amenities on 11.6 acres, located south of Nuevo Road and east of Wilson Avenue: 1) General Plan Amendment and Zone Change to change the land use designation of 11.6 acres from R-6,000 – Single Family Residential to MFR-14 – Multiple Family Residential; 2) Planned Development Overlay to allow flexibility from the MFR-14 development standards; 3) Tentative Tract Map to consolidate 57 parcels into one condominium lot and two lettered lots; and 4) Development Plan Review for review of the site plan and building elevations. Applicant: Ryan Woosley, D.R. Horton

• **GENERAL CONDITIONS:**

1. **Mitigation Monitoring Program.** The project shall fully comply with all provisions of the adopted Mitigation Monitoring and Reporting Program (MMRP), which shall be implemented in accordance with the timeline, reporting, and monitoring intervals listed.
2. **Tentative Tract Map 23-05244 (TTM 38775).** There is a 24-month time limit for satisfying the conditions and recording the map after the City Council approval. A maximum of six (6) subsequent one-year time extensions may be granted by the City Council upon request by the applicant. A written request for an extension of time shall be submitted to the Planning Division at least 30 days before the expiration of the map.
3. **Approval Period for Planned Development Overlay (PDO) Zone 23-05246 and Development Plan Review 23-00019.** Planned Development Overlay and Development Plan Review related to an implementing subdivision may be granted time extensions by the City Council up to a total of six (6) years beyond the original approval expiration date before the issuance of any building permits. Once a building permit has been issued, the Planned Residential Development will be considered vested, and time extensions will no longer be required. A written request for an extension of time shall be submitted to the Planning Division at least 30 days before the expiration date. The approval period of these applications shall be extended with the approval period of the Tentative Parcel Map or to align with automatic state extensions for the Tentative Parcel Map.

4. **Indemnification.** The developer/applicant shall indemnify, protect, defend, and hold harmless the City and any agency or instrumentality thereof and/or any of its officers, employees, and agents from any and all claims, actions, or proceedings against the City or any agency or instrumentality thereof, or any of its officers, employees, and agents, to attack, set aside, void, annul, or seek monetary damages resulting from approval of the City, or any agency or instrumentality thereof, advisory agency, appeal board or legislative body including actions approved by the voters of the City concerning **General Plan Amendment (GPA) 23-05247, Zone Change (ZC) 23-05245, Planned Development Overlay (PDO) Zone 23-05246, Tentative Tract Map 23-05244 (TTM 38775), Development Plan Review (DPR) 23-00019.** The City shall promptly notify the applicant of any claim, action, or proceeding for which indemnification is sought and shall cooperate fully in the defense of the action.
 5. **Notice of Determination.** Within five (5) days of City Council approval, the applicant shall work with Planning Staff on filing a Notice of Determination and applicable fee for the project Mitigated Negative Declaration to the Riverside County Clerk Recorder, in accordance with Section 753.5, (Title 14) of the California Code of Regulations; no project shall be operative, vested, or final until the filing fees have been paid.
- **PLANNING DIVISION**
6. **Perris Municipal Code.** The project shall conform to the development standards of the MFR-14 Zone, as outlined in Chapter 19.26, and the Planned Development Overlay Zone requirements, as specified in Chapter 19.59 of the Perris Municipal Code, as approved for this project.
 7. **Expansion of Use.** The site or its use may not be expanded without subsequent reviews and approvals by the Planning Division.
 8. **Conformance to Approved Plans.** Development of the project site, building elevations, and conceptual landscaping shall conform substantially to the plans approved by the Planning Commission, or as amended by final approval by the City Council. Any deviation shall require appropriate Planning Division consideration.
 9. **Advisory:** Signs shall be permitted in accordance with Chapter 19.75 Sign Regulations of the Zoning Code. Signs shall be subject to separate review and assessment. A separate application and fee will be required.
- Prior to Map Recordation:*
10. **Mitigation Measures.** All applicable mitigation measures shall be satisfied.
 11. **Street Names Request.** The applicant shall submit a Street Names Request to the Planning Division for Planning Commission review and approval. A separate application and applicable fee shall apply.
 12. **Final Map Recordation.** Prior to the recording of the Final Tract Map, the developer shall submit two separate applications and fees, one application to the Planning Division and a

second application to the Engineering Department for review and approval for City Council action.

13. **Assessment and Community Facilities Districts.** The project shall be annexed into any assessment, community facilities, or similar district that provides funding for maintenance, services, or public improvements that benefit the project, or provision shall be made satisfactory to the City for providing these services in the applicable district. The costs and benefits shall be described in the applicable district and annexation documents. The developer shall complete all applicable annexations prior to issuance of any grading permit, issuance of any building permit, or recordation of a Final Map, whichever occurs first. In addition to districts that exist as of the date of project approval, this condition shall include later-formed districts provided that such districts are in existence as of the time of issuance of any grading permit or building permit for the project, as applicable. Such districts may include but are not limited to the following:
 - a. Landscape Maintenance District No. 1;
 - b. Flood Control Maintenance District No. 1;
 - c. Maintenance District No. 84-1;
 - d. Perris Community Facilities Assessment District; and
 - e. Any other applicable City Assessment and Community Facilities Districts

14. **Homeowners Association.** The applicant shall prepare and record Covenants, Conditions, and Restrictions (CC&Rs) creating a Homeowners Association (HOA), subject to approval of the Planning Division and City Attorney's Office. The CC&Rs/HOA shall contain the following:
 - a. Each buyer shall sign and acknowledge that he/she has read the Constitution and By-Laws of the HOA and the CC&Rs applying to the development, including any clause pertaining to private streets and private driveways.
 - b. The CC&Rs shall be irrevocably written and recorded so that the maintenance is the responsibility of the HOA for the life of the project. The CC&Rs shall clearly state that the HOA officers are responsible for the enforcement of the on-street parking regulations.
 - c. Before the recording of the Articles of Incorporation, City Attorneys require an additional deposit to review the AOs.
 - d. The By-Laws or other appropriate document of the HOA shall include the obligations of the Association concerning the maintenance of landscaping along the street frontages; primary and secondary entrances; common open space areas, including maintenance of natural open space parcels, maintenance of recreation areas and equipment, the pool house building, swimming pool, and spa; perimeter wall and entry gates, parking areas, and private streets.
 - e. The HOA shall also act as the Architectural Review Board for the project, strictly enforcing compliance with approved home design, materials, colors, proposed additions, patio covers, etc., prior to submitting the proposed changes to Planning and

Building and Safety Divisions for review and approval.

- f. Vehicles parked on a residential driveway shall not encroach into the sidewalk or private street.
- g. Graffiti on all exterior walls or common space buildings shall be removed within 48 hours of complaint. Also, refer to Condition of Approval No. 47.
- h. All marked parking stalls within the community shall be perpetually maintained.

Prior to Grading Permit Issuance:

- 15. **Mitigation Measures.** All applicable mitigation measures shall be satisfied.
- 16. **Precise Grading Plans.** Precise grading plans shall be submitted to the City Engineer for review and approval. Grading plans shall be consistent with approved development plans.
- 17. **Traffic Control Plan.** A Traffic Control Plan shall be submitted for approval to the City Engineer.
- 18. **Southern California Edison (SCE).** The developer/owner shall contact the Southern California Edison (SCE) area service planner (951-928-8323) to complete the required forms before the commencement of construction. No grading permits shall be issued until a letter from SCE is received by the City Engineer indicating that the electrical service will be placed underground.
- 19. **Eastern Municipal Water District (EMWD).** After the City's approval, the applicant shall also submit landscape plans to EMWD for approval and comply with required EMWD inspections. Contact EMWD at 951 928-3777, ext. 4334.
- 20. **Preliminary Water Quality Management Plan (PWQMP).** A Preliminary WQMP was prepared for the proposed project site. All PWQMPs were determined to be in substantial compliance, in concept, with the 2012 Riverside County WQMP Manual requirements as of January 5, 2025. The following conditions apply:
 - a. The development shall be subject to all provisions of City of Perris Ordinance Number 1194, which establishes stormwater/urban runoff management and discharge controls to improve water quality and comply with federal regulations, and any subsequent amendments, revisions, or ordinances pertaining thereto.
 - b. The structural BMPs selected for this project have been approved in concept. The owner shall submit a final WQMP including plans and details providing the elevations, slopes, and other details for the proposed structural BMPs including one bio-retention basins, lot-specific LID BMPs, and self-retaining landscape. The Public Works Department shall review and approve the final WQMP text, plans and details.
- 21. **Final Water Quality Management Plan (FWQMP).** Prior to the issuance of grading permits, an FWQMP is required to be submitted. To mitigate impacts related to pollutant loading to receiving waters and/or increased erosion/siltation resulting from the long-term

operation of the project, the applicant shall develop, receive approval from the City, and implement an FWQMP. The FWQMP shall contain measures that will effectively treat all pollutants of concern and hydrologic conditions of concern, consistent with the Preliminary WQMP and developed in compliance with the MS4 permit. The FWQMP shall specifically identify pollution prevention, source control, treatment control measures, and other Best Management Practices (BMPs) that shall be used on-site to control predictable pollutant runoff to reduce impacts to water quality to the maximum extent practicable. The FWQMP shall substantially comply with site design, source control, and treatment control BMPs proposed in the approved Preliminary Water Quality Management Plan (PWQMP).

Prior to Building Permit Issuance:

22. **Recorded Map.** Tentative Tract Map 38775 shall be recorded.
23. **Mitigation Measures.** All applicable mitigation measures shall be satisfied.
24. **Construction Drawings.** All Planning, Public Works, Building, Community Services and Engineering conditions of approval and mitigation measures shall be copied on the construction drawings. The Conditions shall be annotated for ease of reference (i.e. Sheet and detail numbers).
25. **School District.** The proposed project shall adhere to the standard requirements and mitigation fees established by the Perris Union High School District and Perris Elementary School District.
26. **Lighting.** Plans shall include decorative coach lighting for each home, depending on the architecture; the applicant shall work with staff on the location and appropriate lighting fixtures for each home. In addition to decorative coach lighting, the home builder must provide lighting at all exterior doorway entrances, including the front door entrance, side-door entrances, and rear/sliding door entrances. Lighting shall consist of either coach lighting or under-soffit lighting.
27. **Construction Practices.** To reduce potential noise and air quality nuisances, the following items shall be listed as "General Notes" on the construction drawings:
 - a. Construction activity and equipment maintenance are limited to weekday hours between 7:00 a.m. and 7:00 p.m. Construction may not occur on weekends or State holidays without the prior consent of the Building Official. Non-noise-generating activities (e.g., interior painting) are not subject to these restrictions.
 - b. Construction routes are limited to City of Perris-designated truck routes or permitted by the City Engineer.
 - c. Water trucks or sprinkler systems shall be used during clearing, grading, earth moving, excavation, transportation of cut or fill materials, and construction phases to prevent dust from leaving the site and to create a crust after each day's activities cease. At a minimum, this would include wetting down such areas in the late morning and after work is completed for the day and whenever wind exceeds 15 miles per hour.

- d. A person or persons shall be designated to monitor the dust control program and to order increased watering as necessary to prevent the transport of dust off-site. The name and telephone number of such people shall be provided to the City. Also, a board shall be placed at the subject site to include a person and phone number for the public to call in case of dirt and dust issues.
 - e. Project applicants shall provide construction site electrical hook-ups for electric hand tools, such as saws, drills, and compressors, to eliminate the need for diesel-powered electric generators or provide evidence that electrical hook-ups at construction sites are not practical or prohibitively expensive.
28. **ADA Compliance.** The project shall conform to all disabled access requirements in accordance with the State of California, Title 24, and the Federal Americans with Disabilities Act (ADA).
 29. **Screening of Roof-Mounted Equipment.** No roof-mounted equipment is proposed for this project. If applicable, proper screening shall prevent public views of all HVAC equipment and roof-mounted equipment. Additionally, all vent pipes and similar devices shall be painted to match the building's exterior.
 30. **Mechanical Equipment.** All mechanical equipment, including air conditioning units, pool equipment, etc., shall be screened from the public right-of-way by a view-obscuring fence, wall, or landscaping to the satisfaction of the Planning Division.
 31. **Downspouts.** Exterior downspouts are not permitted on building elevations facing the public right-of-way, unless they are used as a decorative feature on the home or HOA buildings. Otherwise, downspouts should be focused away from the façade of the home/HOA building.
 32. **Trash Enclosures.** If required, any trash enclosure shall be screened with landscaping (vines and shrubs) and provide decorative solid trellis cover per the development plans presented to the Planning Commission. Furthermore, the trash enclosure location shall have an ADA path of travel from each building to the trash enclosure it is meant to serve.
 33. **Utilities.** If applicable, all utilities such as cable TV and electrical distribution lines (including those that provide direct service to the project site and/or currently exist along public right-of-way) adjacent to the site shall be placed underground, except for electrical utility lines rated at 65KV or larger.
 34. **On-site & Off-site Utilities.** All utilities attached to buildings, including meters and utility boxes, shall be painted to match the wall of the building to which they are affixed. These facilities shall also be screened from the public right-of-way by landscaping.
 35. **Landscape and Irrigation Plans.** Submit three (3) copies of the landscape and irrigation plans to the Planning Division for review and approval. Design modifications may be required as deemed necessary. A separate application and applicable fee are required. Landscape plans shall comply substantially with the conceptual plans approved by the City Council. The plans shall be prepared by a California-registered Landscape Architect and

conform to the requirements of Chapter 19.70 – Landscaping of the Perris Municipal Code. The following shall be included:

- a. **Street Frontages.** All landscaping fronting onto the perimeter of the project site, main entrances and adjacent to the surrounding streets shall consist of tiered plant materials subject to Planning staff review and approval.
 - b. **EMWD.** Landscape plans shall be submitted concurrently to the Eastern Municipal Water District (EMWD) for review and approval.
 - c. **BMPs for Water Quality.** All BMPs (vegetated swales, etc.) shall be landscaped and shown on the landscape plans with appropriate planting and irrigation. Trees shall be planted as closely as possible to screen the bio-retention areas.
 - d. **Water Conservation.** Landscaping must comply with AB 325 for water conservation. Refer to Chapter 19.70 – Landscaping, for water conservation calculations (MAWA).
 - e. **Maintenance.** All required landscaping shall be maintained in a viable growth condition for the project's life.
 - f. **Irrigation Rain Sensors.** Rain-sensing override devices shall be required on all irrigation systems (PMC 19.70.040.D.16.b) for water conservation. Soil moisture sensors are required.
36. **Enhanced Elevations.** As noted on the plans, all homes visible to adjacent roadways and all corner lots shall have enhanced elevations.
37. **Phasing.** The final project phasing shall be approved by Planning Staff.
38. **Model Home Complex.** All project amenities (perimeter wall, gates, clubhouse, landscaping, open space amenities near clubhouse, etc.) shall be installed before the project's completion of the model home complex. A separate planning application with fee are required for the model home complex.
39. **Fence and Wall Plan.** The applicant shall submit the final fence and wall plans to Planning staff for review and approval. Plans shall comply substantially with the plans approved by the City Council also labeled as “Acacia Fencing Plan.” Revise the fence and wall plan such that the plan incorporates the following:
- a. **Tubular Steel Fence.** Decorative pilasters and caps shall be added at prominent corners and throughout the tubular steel fencing to break up the massing.
 - b. **Additional Fencing.** Additional fencing shall be consistent with height, colors and materials approved for this project. Any additional fencing not shown on the plans shall be reviewed and approved by Planning staff. Chain link and wood fencing or other types of fencing are not allowed.
 - c. **Fencing for Private Space.** All fencing shall be made of high-quality vinyl to mimic the appearance of wood.

- d. **Graffiti.** All decorative masonry walls shall be treated with a graffiti-resistant coat. Also refer to Condition of Approval No. 47.
 - e. **Knox Boxes.** Knox boxes are required for all gates and shall be approved by the Fire Marshal and issued by the Building Division.
40. **Photometrics Plan (Site Lighting Plan).** The applicant shall submit a Photometrics Plan to the Planning Division for review and approval. Full cut-off, low-sodium fixtures shall be used to prevent light and glare above the horizontal plane of the bottom of the lighting fixture. A minimum of one (1) foot-candle of light shall be provided in parking and pedestrian areas, amenities, walkways, and the pool building area. Street lighting shall comply with Engineering requirements.
41. **Fees.** The developer shall pay the following fees before the issuance of building permits:
- a. Stephen's Kangaroo Rat Mitigation Fees of \$500.00 per acre.
 - b. Multiple Species Habitat Conservation Plan fees.
 - c. Current statutory school fees to all appropriate school districts.
 - d. Any outstanding liens and development processing fees owed to the City.
 - e. Appropriate Road and Bridge Benefit District fees.
 - f. Park Development Impact fee.
 - g. City Development Impact fees.
 - h. Transportation Uniform Mitigation Fees (TUMF).
 - i. Appropriate City Development Impact Fees in effect at the time of development.

During Construction:

42. **Waste Hauling and Disposal.** The project shall use only the City-approved waste hauler for all construction and other waste disposal.

Prior To Issuance of Occupancy Permits

43. **On-Site Landscape Inspections.** The project applicant shall inform the on-site project manager and the landscape contractor of their responsibility to call for a final landscape inspection after all the landscaping and irrigation have been installed and are completely operational. Before calling for a final inspection, submit the "Certificate of Compliance" form completed and signed by the designer/auditor responsible for the project to the Project Planner.
44. **Final Inspection.** The applicant shall obtain occupancy clearance from the Planning Division by scheduling a final Planning inspection after final sign-offs from the Building

Division and Engineering Department. Planning staff shall verify that all pertinent conditions of approval have been met. The applicant shall have all the required paving, parking, walls, site lighting, landscaping and automatic irrigation installed and in good condition.

Operational Conditions:

45. **Property Maintenance.** The project shall comply with the provisions of Perris Municipal Codes 7.42 regarding Landscape Maintenance, and Chapter 7.06 regarding Property Maintenance. In addition, the project shall comply with the one-year landscape maintenance schedule.
46. **Temporary Uses.** Per Chapter 19.60 of the City of Perris Municipal Code, any outdoor use of the common space for special events that will require temporary structures or tents shall be required to apply for a Temporary Use Permit as described in Section 19.60.060 of the City of Perris Municipal Code.
47. **Graffiti and Property Maintenance.** The project shall comply with the Perris Municipal Code Chapters 7.06 regarding Property Maintenance, and Chapter 7.26 regarding Graffiti Removal. The site shall be maintained in a graffiti-free state at all times. The site shall always be maintained in a graffiti-free state. Graffiti located on site shall be removed within 48 hours. Graffiti shall be painted over panels, not patches. In addition, it will match the color of the wall or material surface. Furthermore, the applicant shall apply an anti-graffiti coating on the walls.

- **ENGINEERING DEPARTMENT**

48. The project shall adhere to the requirements of the City Engineer, as indicated in the attached Engineering Conditions of Approval dated **May 1, 2025**. The city engineer shall review and approve on- and off-site improvement plans.

- **PUBLIC WORKS DEPARTMENT**

49. The project shall adhere to the requirements of the Public Works Administration Department as indicated in the attached Conditions of Approval dated **May 1, 2025**.

- **COMMUNITY SERVICES DEPARTMENT**

50. The project shall adhere to the requirements of the Community Services Department as indicated in the attached Conditions of Approval dated **April 9, 2025**.

- **BUILDING & SAFETY DIVISION**

51. The project shall adhere to the Building & Safety Division requirements as indicated in the attached Conditions of Approval dated **October 16, 2023**.

- **BUILDING OFFICIAL/FIRE MARSHAL**

52. The proposed project shall adhere to all Building Official/Fire Marshal requirements. Fire hydrants shall be located on the project site pursuant to the Building Official and the approved Fire Access Plan. Water, gas, sewer, electrical transformers, power vaults, and separate fire/water supply lines (if applicable) must be shown on the final set of construction plans pursuant to the requirements of the Building Official. All Conditions of Approval shall be included in the building plans. See the City of Perris website, Office of the Fire Marshal, for examples and relevant information for access and the underground plan available at: <http://www.cityofperris.org>.

• **RIVERSIDE COUNTY AIRPORT LAND USE COMMISSION**

53. Any new outdoor lighting that is installed shall be hooded or shielded so as to prevent either the spillage of lumens or reflection into the sky. Outdoor lighting shall be downward facing.

54. The following uses/activities are not included in the proposed project and shall be prohibited at this site:

- a. Any use which would direct a steady light or flashing light of red, white, green, or amber colors associated with airport operations toward an aircraft engaged in an initial straight or circling climb following takeoff or toward an aircraft engaged in a straight or circling final approach toward a landing at an airport, other than a DoD or FAA-approved navigational signal light or visual approach slope indicator.
- b. Any use which would cause sunlight to be reflected towards an aircraft engaged in an initial straight or circling climb following takeoff or towards an aircraft engaged in a straight or circling final approach towards a landing at an airport.
- c. Any use which would generate smoke or water vapor, or which would attract large concentrations of birds, or which may otherwise affect safe air navigation within the area. (Such uses include landscaping utilizing water features, agriculture, production of cereal grains, sunflower, and row crops, composting operations, wastewater management facilities, artificial marshes, trash transfer stations that are open on one or more sides, recycling centers containing putrescible wastes, construction and demolition debris facilities, fly ash disposal, and incinerators.)
- d. Any use that would generate electrical interference that may be detrimental to the operation of aircraft and/or aircraft instrumentation.
- e. Hazards to flight

55. The attached notice shall be provided to all prospective purchasers of the property and tenants of the building, and shall be recorded as a deed notice.

56. Any proposed detention basins or facilities shall be designed and maintained to provide for a maximum 48-hour detention period following the design storm, and remain totally dry between rainfalls. Vegetation in and around the detention basins that would provide food

or cover for birds would be incompatible with airport operations and shall not be utilized in project landscaping. Trees shall be spaced so as to prevent large expanses of contiguous canopy, when mature. Landscaping in and around the detention basin(s) shall not include trees or shrubs that produce seeds, fruits, or berries.

Landscaping in the detention basin, if not rip-rap, should be in accordance with the guidance provided in ALUC "LANDSCAPING NEAR AIRPORTS" brochure, and the "AIRPORTS, WILDLIFE AND STORMWATER MANAGEMENT" brochure available at RCALUC.ORG which list acceptable plants from Riverside County Landscaping Guide or other alternative landscaping as may be recommended by a qualified wildlife hazard biologist.

A notice sign, in a form similar to that attached hereto, shall be permanently affixed to the stormwater basin with the following language: "There is an airport nearby. This stormwater basin is designed to hold stormwater for only 48 hours and not attract birds. Proper maintenance is necessary to avoid bird strikes". The sign will also include the name, telephone number or other contact information of the person or entity responsible to monitor the stormwater basin.

57. March Air Reserve Base must be notified of any land use having an electromagnetic radiation component to assess whether a potential conflict with Air Base radio communications could result. Sources of electromagnetic radiation include radio wave transmission in conjunction with remote equipment inclusive of irrigation controllers, access gates, etc.
58. The project has been evaluated to construct 141 townhomes and amenities on 11.62 acres, any change in use to any higher intensity use, change in building location, or modification of the tentative parcel map lot lines and areas will require an amended review to evaluate consistency with the ALUCP compatibility criteria, at the discretion of the ALUC Direct

- **FIRE MARSHAL**

59. The project shall comply with all requirements set forth by the California Code of Regulations Title 24 Parts 1-12 respectively.
60. The adopted edition of the California Code of Regulations, Title 24, Parts 1 through 12, and the Perris Municipal Code shall apply at the time the architectural plans are submitted for construction permits.
61. Prior to the issuance of grading permits, a fire department access plan shall be submitted to the City of Perris for review and approval. The fire department access plan shall comply with the requirements specified by the City of Perris Guideline for Fire Department Access & Water Requirements for Commercial & Residential Development, and the California Fire Code, Chapter 5.

62. Prior to the issuance of grading permits, evidence of sufficient fire flow of 1500 GPM for 2 hours shall be provided to the City of Perris. The City of Perris Building and Fire Marshal Water Available/Fire Flow Form shall be utilized.
63. A fire department access road complying with the CFC, Chapter 5 and the approved fire department access plans shall be installed prior to building construction.
64. All required fire hydrants shall be installed and operational prior to building construction. All fire hydrants shall remain operational during construction.
65. All required fire hydrants shall be readily visible and immediately accessible. A clear space of not less than 3 feet shall always be maintained.
66. The maximum distance between hydrants is 300 feet.
67. A minimum of two points of connection to the public water system shall be provided for the private fire-line water. The private underground fire-line system shall be a looped design.
68. Any Fire Department Connections (FDCs) shall be located within 100 feet of a public fire hydrant. The fire hydrant shall be on the same side of the street. A vehicle access roadway/approach shall not be placed between the FDC and fire hydrant.
69. Prior to construction a temporary address sign shall be posted and clearly visible from the street.
70. The permanent building address shall be provided and either internally or externally lit during hours of darkness. The address shall be clearly visible from the street fronting the property and comply with California Fire Code Section 505.1 for size and color.
71. The buildings shall be provided with an automatic fire sprinkler system in accordance with NFPA 13. Construction plans shall be submitted for review and approval to the City of Perris prior to installation.
72. Prior to building final, the recreation building and all security gates shall be provided with a Knox Lock key box or key switch. The Knox box shall no more than seven feet above the finished surface and near the main entrance door.
73. Security gates shall be located at least 56 feet from any major street.
74. City of Perris approval shall be obtained prior to the storage and/or use of hazardous materials as defined by the California Fire Code.

END OF CONDITIONS



CITY OF PERRIS

ENGINEERING DEPARTMENT

CONDITIONS OF APPROVAL

May 1, 2025

PLN 23-05244 (TTM 38755)

GPA 23-05247

ZC 23-05245

PDO 23-05246

Acacia Point Towne Homes

Lots 1-57 of TM 31651 (MB 419/12-14)

With respect to the Conditions of Approval for the above referenced project, the City of Perris requires that the developer/property owner provides the following street improvements and/or road dedications in accordance with the City of Perris Municipal Code Title 18. It is understood that the site plan correctly shows all existing and proposed elements, traveled ways, right-of-way, and drainage courses with appropriate Q's and their omission may require the site plan to be resubmitted for further consideration. These ordinances and the following conditions are essential parts and requirements occurring in ONE is as binding as though occurring in all. They are intended to be complimentary and to describe the conditions for a complete design of the improvements. Unless otherwise noted, all offsite improvements as conditioned shall be installed prior to issuance of any occupancy permits. All questions regarding the true meaning of the conditions shall be referred to the City Engineer's office.

In the event of a conflict between any conditions stated below, those imposed by the Planning Department and others, and requirements identified in the approved Traffic Impact Analysis, the most stringent in the City's opinion shall prevail.

General Conditions:

1. The project's grading shall be in a manner to perpetuate existing natural drainage patterns. Any deviation from this, concentration or increase in runoff must have approval of adjacent property owners and City Engineer. The

developer/property owner shall accept the offsite runoff and convey to acceptable outlet.

2. Prior to commencement of any construction or installation of fencing in public right-of-way, an encroachment permit shall be obtained from the City Engineer's office.

3. In the event that external agencies must review the plans and inspect improvements, the developer/property owner shall be responsible to pay the respective plan check and inspection fees.

4. All trenches shall be securely covered with steel plates until permanent backfill and street repairs have been completed per City of Perris Standards; temporary backfill of trenches is not acceptable.

5. The developer/property owner shall provide for all traffic mitigation measures and improvements as depicted in the Traffic Impact Analysis prepared by TJW Engineering, Inc. dated November 8, 2024 and as conditioned below as approved by the City Engineer including but not limited to:

a. Two points of access/driveways are permitted on Wilson Avenue.

i. The northerly driveway shall be gated, allowing for full access movements and shall have a minimum width of 54 feet at the turnaround point.

ii. The southerly driveway shall be gated and designated for egress only full access movement, with entry restricted to emergency vehicles only.

b. Nuevo Road (Modified Primary Arterial – 128'/86') along the property frontage within the dedicated right-of-way, from Wilson Avenue to the easterly project limits, shall be improved to provide for the following improvements:

i. 8-inch curb and gutter 43-feet south from the centerline.

ii. New raised landscape median to match existing width and curb height. Layout of median shall be per the attached exhibit hereon.

iii. Grind and overlay, curb-to-curb new AC pavement, to a 2-inch depth and replace with 2 inches from Wilson Avenue to the easterly project limits.

Remove and replace areas of existing distressed pavement at full depth, constructing new rectangular pavement sections. Final structural section will be determined at the discretion of the City Engineer. Using a Traffic Index (TI) of 10.0, the minimum pavement structural section includes 8 inches of Asphalt Concrete PG70-10 over 16 inches of Class II Aggregate Base.

iv. The parkway shall be 21-foot-wide consisting of a 6-foot-wide sidewalk, 15-feet of landscaping, Class II Bike Lane, a second through lane at the eastbound leg of its intersection at Wilson Avenue and continuing east toward Murrieta Road along the project site frontage, and streetlights subject to the results of a photometric study prepared by a registered Electrical Engineer per City of Perris Safety Lighting Standards, County of Riverside and Caltrans standards.

c. Wilson Avenue (Local 60'/40') along the property's frontage within dedicated right-of-way, from Nuevo Road to the southerly project limits, shall be improved to provide for the following improvements:

- i. 6-inch curb and gutter 20-feet east from the centerline.
- ii. A total limit of 40 feet of full-width pavement.

Grind and overlay, curb-to-curb new AC pavement, to a 2-inch depth and replace with 2 inches from Nuevo Road to the southerly project limits.

Remove and replace areas of existing distressed pavement at full depth, constructing new rectangular pavement sections. Final structural section will be determined at the discretion of the City Engineer. Using a Traffic Index (TI) of 7.0, the minimum pavement structural section includes 6 inches of Asphalt Concrete PG70-10 over 8 inches of Class II Aggregate Base.

iii. The parkway shall be 10-foot-wide consisting of a 6-foot-wide sidewalk, 4-feet of landscaping, and streetlights subject to the results of a photometric study prepared by a registered Electrical Engineer per City of Perris Safety Lighting Standards, County of Riverside and Caltrans standards.

6. The driveways shall be per County of Riverside Standard No. 207A and shall include wet set concrete truncated domes in compliance with ADA standards and requirements. The driveways curb returns shall be within the property limits and shall not infringe on adjacent properties.

7. The developer/property owner shall provide for all drainage mitigation measures and improvements as depicted in the Preliminary Hydrology and Hydraulics Study prepared by SP2 & Co. dated September 13, 2023 and as conditioned below as approved by the City Engineer including but not limited to:

a. The developer/property owner shall collect any off-site runoff along the northwest corner of the project site and convey it to an acceptable outlet.

- b. The developer/property owner shall collect on-site treated runoff and convey it to the public underground drainage system.
 - c. Catch basin inserts shall be provided as approved by the Public Works Department.
 - d. The storm drain systems shall be designed per Riverside County Flood Control and Water Conservation District (RCFCD) and City of Perris design and WQMP standards and guidelines.
8. An encroachment permit shall be obtained for any work that is to be performed within the RCFCD right-of-way or impacting District facilities. The encroachment permit application shall be processed and approved concurrently with the improvement plans.

Prior to Recordation of the Tract Map:

9. The developer/property owner shall have the aforementioned improvement plans and tract map approved, executed subdivision agreement and posted securities prior to map recordation.
10. A tract map shall be filed with the City and processed for review, approval, and subsequent recordation.
11. Relinquish and waive rights of access to and from Wilson Avenue and Nuevo Road on the Final Tract Map other than the two openings on Wilson Avenue as delineated on the approved Tentative Tract Map.
12. The following easements and/or rights-of-way shall be offered for dedication to the public or other appropriate agencies in perpetuity and shall continue in force until the City or the appropriate agency accepts or abandons such offers:
- a. Wilson Avenue is classified as a Local Road (60'/40'), per the General Plan. Adequate right-of-way shall be dedicated on Watson Road, along the property frontage, to accommodate a 30-foot half-width dedicated right-of-way, as determined and approved by the Planning Department, Public Works Department, and the City Engineer.
 - b. Nuevo Road is classified as a Modified Primary Arterial (128'/86'), per the General Plan. Adequate right-of-way shall be dedicated on Watson Road, along the property frontage, to accommodate a 64-foot half-width dedicated right-of-way, as determined and approved by the Planning Department, Public Works Department, and the City Engineer.
 - c. Property line corner cutbacks shall be dedicated per County of Riverside Standard No. 805.

- d. Easements shall be dedicated to public utilities and emergency vehicle access for all private streets and drive-isles.
- e. Reciprocal access, parking and drainage easements shall be provided and so noted on the Final Tract Map.

13. The following statement shall be added to the Final Tract Map:

NOTICED OF DRAINAGE FEES. Notice is hereby given that this property is located in the Perris Valley Area Drainage Plan which was adopted by the City of Perris pursuant to Ordinance and Section 66483 et seq, of the Government Code and that said property is subject to fees for said drainage area. Notice is further given that, pursuant to Ordinance 13-01, payment of the drainage fees shall be paid to the City of Perris prior to issuance of the grading permit or building permit at the rate in effect at the time of issuance of this actual permit.

14. The project shall be annexed into any assessment, community facilities, or similar district that provides funding for maintenance, services, or public improvements that benefit the project, or provision shall be made satisfactory to the City for providing these services in the applicable district. The costs and benefits shall be described in the applicable district and annexation documents. The developer shall complete all applicable annexations prior to issuance of any grading permit, issuance of any building permit, or recordation of a Final Map, whichever occurs first. In addition to districts that exist as of the date of project approval, this condition shall include later-formed districts provided that such districts are in existence as of the time of issuance of any grading permit or building permit for the project, as applicable. Such districts may include but are not limited to the following:

- a. Landscape Maintenance District No. 1
- b. Flood Control Maintenance District No. 1 (may include Streets)
- c. Maintenance District No. 84-1 (Street Lights and Traffic Signals)
- d. Perris Community Facilities Assessment Districts; and
- e. Any other applicable City Assessment, Community Facilities Districts

Prior to Issuance of Grading Permit:

15. The project site is within the limits of FEMA 100-year flood plain. The developer/property owner shall process the CLOMR.

16. Tributary and treated onsite runoff shall be collected and connected via underground storm drain facility, to Perris Valley Master Drainage Facility (PVMDP) Line L and Line A as approved by the City Engineer.

17. The developer/property owner shall submit the following to the City Engineer for review and approval:

- a. Onsite Grading Plan and Erosion Control Plan – Plans shall show the approved WDID No.
- b. Street and Storm Drain Improvement Plans
- c. Sewer and Water Improvement Plans
- d. Signing and Striping Plan
- e. Final Drainage Plan, Hydrology and Hydraulic Report
- f. Street Light Plan prepared by a Registered Electric Engineer per City of Perris Standards; streetlights shall be per City of Perris Safety Lighting Standards.
- g. Geotechnical Report
- h. Final WQMP (for reference)

The design shall be in compliance with EMWD, RCFCD, Riverside County Transportation Department, Caltrans, City of Perris and ADA most recent standards, criteria and requirements and in effect at the time of construction and shall be coordinated with the approved plans of the adjacent developments.

18. In the event that the electrical cables are under 66 kV, the existing power poles on Wilson Avenue and Nuevo Road along the frontage of the property, shall be removed, and the electrical and communication cables shall be placed underground.

19. If the electrical cables exceed 66 kV, the existing power poles shall be relocated to accommodate the roadway widening. The developer/property owner shall provide an analysis from a utility consultant verifying compliance with this condition. In any event the communication cables shall be placed underground.

20. The project shall be annexed into any assessment, community facilities, or similar district that provides funding for maintenance, services, or public improvements that benefit the project, or provision shall be made satisfactory to the City for providing these services in the applicable district. The costs and benefits shall be described in the applicable district and annexation documents. The developer shall complete all applicable annexations prior to issuance of any grading permit, issuance of any building permit, or recordation of a Final Map, whichever occurs first. In addition to districts that exist as of the date of project approval, this condition shall include later-formed districts provided that such districts are in existence as of the time of issuance of any grading permit or building permit for the project, as applicable. Such districts may include but are not limited to the following:

- a. Landscape Maintenance District No. 1
- b. Flood Control Maintenance District No. 1 (may include Streets)
- c. Maintenance District No. 84-1 (Street Lights and Traffic Signals)
- d. Perris Community Facilities Assessment Districts; and
- e. Any other applicable City Assessment, Community Facilities Districts

Prior to Issuance of Building Permit:

21. The developer/property owner shall process Tract Map 38775 with the City for review and approval and subsequent recordation.

22. The developer/property owner shall submit a compaction certificate from the Soils Engineer in compliance with the approved geotechnical/soils report and an elevation certification from the Engineer of Record in compliance with the approved plans.

23. Paved access shall be provided to the proposed buildings per the Precise Grading Plans.

24. The project site is located within the limits of Perris Valley Area Drainage Plan (ADP) for which drainage fees have been adopted by the City. Drainage fees shall be paid as set forth under the provisions of the "Rules and Regulation of Administration of Area Drainage Plan".

Prior to issuance of Certificate of Occupancy:

25. Prior to issuance of the first occupancy permit the developer/property owner shall process the LOMR.

26. Prior to issuance of the first occupancy permit the developer/property owner shall complete the construction of all public improvements on Wilson Avenue and Nuevo Road, as specified above and approved by the City.

27. Associated existing signing and striping shall be refreshed and any appurtenances damaged or broken during the development of this project shall be repaired or removed and replaced by the developer/property owner to the satisfaction of the City Engineer. Any survey monuments damaged or destroyed shall be reset by qualified professional pursuant to the California Business and Professional Code 8771.

28. The developer/property owner shall complete the construction of all public improvements, including but not limited to roadway improvements and drainage improvements as specified above and accepted by the City.



CITY OF PERRIS
PUBLIC WORKS DEPARTMENT

MEMO

Date: May 1, 2025

To: Nathan Perez, Senior Planner

From: Liset Hernandez, Public Works Manager

By: Chris Baldino, Landscape Inspector

Subject: **TTM 38775, GPA23-05247, ZC23-05245, PDO23-05246**
Conditions of Approval: Proposal to construct 145 townhomes and amenities on 11.62 acres located on the southwest corner of Nuevo Road and Wilson Ave.

1. **Dedication and/or Landscape Maintenance Easement.** Offer of Dedication and Landscape Maintenance Easement for City landscape maintenance district shall be provided as follows:
 - **Nuevo Road** - Provide offer of dedication as needed to provide for full half width Street (128'ROW, 64' halfwidth, curb gutter, raised median, sidewalk and off-site landscaping requirements, per City General Plan, including minimum 21' public parkway from face of curb.
 - **Wilson Ave.** - Provide offer of dedication as needed to provide for full half width Street (60'ROW, 30' halfwidth), curb gutter, sidewalk, and off-site landscaping requirements, per City General Plan, including minimum 10' public parkway from face of curb.

2. **Landscape Maintenance Easement and Landscape Easement Agreement** - The developer shall provide, for review and approval, an Offer of Dedication and certificate of acceptance, complete with a legal plat map and legal description to the City of Perris. In addition, if required by the City of Perris, the Developer shall provide a landscape easement and Landscape easement agreement, acceptable to the City of Perris. The City shall record the same with the Riverside County Recorder's Office, and the recorded instrument shall be returned to the City Clerk of the City of Perris for filing, if needed.



CITY OF PERRIS

PUBLIC WORKS DEPARTMENT

3. **Landscaping Plans** - Three (3) copies of Construction Landscaping and Irrigation Plans for the off-site landscaping, including any medians or other landscape areas along the dedications shall be submitted to the Planning Department for approval and shall be accompanied by the appropriate filing fee. The landscape and irrigation plan shall be prepared by a registered landscape architect and conform to the requirements of Chapter 19.70 of the Municipal Code. The location, number, genus, species, and container size of the plants shall be shown. This landscape plan shall be titled "Off-site Landscape Plan for TPM38775" and shall be exclusive of any private property, on-site landscaping. Elements of the Landscape Plan shall include but not be limited to:
 - a. **Landscape Limits** – Limits of right-of-way areas or easement areas, defined by concrete mow curbs, fully dimensioned, that are to be annexed into the Landscape Maintenance District. A planting palette and hardscape plan intended to meet the design intent of the Landscape Guidelines in effect for the area; or if no such guidelines exist the design intent of neighboring development, as determined by the Special Districts Division, including:
 - **Nuevo Road** - Streetscape Landscape design guidelines and planting pallet, for Arterial Road. Primary Tree: Magnolia Grandiflora "Southern Magnolia". Use of drought resistant shrubs and ground cover including but not limited to the following: Rhamphiolepis delacourii "Georgia Petite", Lantana sellowiana "Monswee" lantana, Tri-Color Society Garlic, Rosmarinus officinalis "Huntington Carpet".
 - **Wilson Ave** – Streetscape Landscape design guidelines and planting pallet for Collector roads. Street Tree Platanus Acerfolia London Plane. Use drought resistant shrubs and groundcover, including but not limited to the following: Yucca flaccida (Gold Garland), Pennisetum alopecuroides (Hameln) Dwarf, Lantana sellowiana "Monswee" Lantana, and native boulders from the area.
 - **Nuevo Road Median** - The proposed development will benefit from existing landscape maintenance district facilities, including the Nuevo Rd. Medians, which serves the existing development. Therefore, the project shall annex into a new Landscape District Benefit Zone and pay is fair share of the maintenance of the existing median facilities.
 - **Water Quality Basins "A" & "B"** – Water Quality basins to be privately maintained.
 - b. **Irrigation** – A list of irrigation system components intended to meet the performance, durability, water efficiency, and anti-theft requirements for



CITY OF PERRIS

PUBLIC WORKS DEPARTMENT

Special District landscape areas as determined by the Special Districts Division. Components shall include, but not be limited to Rainbird XBT-20PC w/ Diffuser, or equal on flexible PVC risers, Sentry Guard Cable Guard and Union Guard, and backflow Wilkens Model 375 (or equal). The controller shall include an ET based controller with weather station that is centrally controlled capable and wi-fi ready (Weather Trak Pro3, or equal, with Rain Sensor). At the discretion of the Special Districts Division public landscape areas utilizing no more than 6 valves/stations, programmed to irrigate consecutively, and none simultaneously, may propose the use of an alternative ET based controller with weather station that is centrally controlled capable and wi-fi ready, such as the Weathermatic System or equal. The proposed system shall be complete with wireless weather station, aircard with flow, one year bundle service, blade antenna and flow sensor, and ET programmed.

- c. **Benefit Zone Quantities** – Include a Benefit Zone quantities table (i.e. SF of planting areas, turf, number of trees, SF. of hardscape, etc.) in the lower right-hand corner of the cover sheet for off-site landscape areas, indicating the amount of landscaping the district will be required to maintain.
- d. **Meters** – Each District is required to be metered separately. A meter cannot be shared between Flood Control District #1, Landscape Maintenance District #1, and/or Lighting Maintenance District 84-1, nor can a meter servicing on-site improvements be used to provide water and/or power to off-site improvements. All electrical and water meters shall be in locations that are easily accessible to maintenance staff while not visually obtrusive in the street scene and away from street intersections. Show location of separate water and electrical utility meters intended to serve maintenance district areas exclusively. Show locations of water and electrical meter for landscape district. Show location of water and electrical meter for flood control district. Show location of electrical meter for Traffic signal and street lighting district, on respective plans. Coordinate location of meters on landscape and civil engineering plan.
- e. **Controllers** - The off-site irrigation controllers are to be located within the right of way (preferably within the off-site landscape area). All point of connection equipment including irrigation controller pedestals, electrical meter pedestals, and backflow preventers are to be in locations that are easily accessible to maintenance staff while not visually obtrusive in the street scene, and away from street intersections. Backflow preventers are to be screened on at least three sides with (5) gallon plant material. The fourth side shall be open to the back of the landscape area



CITY OF PERRIS

PUBLIC WORKS DEPARTMENT

to allow the backflow cage to be opened without interference with plant materials. Backflow cages shall meet the required City of Perris Engineering Standards in effect at the time of approval.

- f. **Recycled Water** - If applicable. The project landscape architect shall coordinate with EMWD to verify if the site will be served with recycled water and design all irrigation and landscape plans to meet the requirements of EMWD and provide additional irrigation components as needed.
- g. **EMWD Landscape Plan Approval** – The project landscape architect shall submit a copy of all irrigation plans and specifications to EMWD for approval. The project landscape architect must confirm with EMWD that the plans have been approved by EMWD and submit written proof of approval by EMWD prior to the City approving the final Landscape Plans. Until the final landscape plan has been approved by the City of Perris, the maintenance areas depicted cannot be accepted by the City for maintenance. The developer shall coordinate both reviews to ensure acceptability of plans by both EMWD and the City of Perris, prior to approval by either agency.
- h. **Landscape Weed Barrier** - Weed cloth with a minimum expected life of 10-years shall be required under all gravel, rock, or cobble areas.
- i. **Wire Mesh and Gravel at Pull Boxes** - Provide wire mesh and gravel layer within valve boxes to prevent rodent intrusion.
- j. **Concrete Maintenance Band at Medians and Mortar Cobble Turn Lane** – Provide 12” wide concrete maintenance band (safety edge) around entire median. At turn pockets provide mortared cobble creek bed, round stone sized 6” to 12”.
- k. **Perimeter Walls Graffiti Coating** – Provide anti-graffiti coating to all perimeter walls. Acceptable products shall include Vitrocem Anti-Graffiti Coating or equal.
- l. **Slopes 3:1 Maximum** - Any proposed slope will not exceed a 3:1 ratio. Slopes exceeding a 3:1 ratio shall require construction of appropriate reinforcing garden walls.
- m. **SB 1383 Mulch Compliance** – All mulch procured for use on City landscape areas must be produced from green waste sourced from a permitted/registered facility under 14 CCR 18993.1(4)(B). Visit <https://www2.calrecycle.ca.gov/SolidWaste/Site/Search>

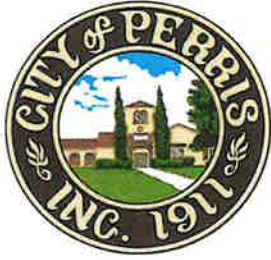

CITY OF PERRIS

PUBLIC WORKS DEPARTMENT

for facility searches. Developer must turn over invoices for such mulch that identify the Direct Procurement or Direct Service Provider name.

4. **Landscape Inspections.** The project applicant shall inform the on-site project manager and the landscape contractor of their responsibility to call for only “OFF-SITE” landscape and irrigation inspections at the appropriate stages of construction. Inspections shall be scheduled for at least two working days (Monday through Friday) during normal staff hours, prior to the actual inspection. Contact Public Works Special Districts Division at (951) 657-3280 to schedule inspections.
- **Inspection #1** – Trenches open, irrigation installed, and system pressurized to 150 PSI for four hours.
 - **Inspection #2** – Soil prepared, and plant materials positioned and ready to plant.
 - **Inspection #3** – Landscaping installed, with all equipment and irrigation system fully operational; including installed and fully operational water meter and electrical meter.
 - **Inspection #4** – A joint inspection with the Development Inspector and LMD Inspector and Applicant to request for “Start of 1 year Maintenance Period” submitted, with all required turn-over submittal items provided to Public-Works Special Districts Division. **The applicant shall be responsible for ensuring that a 6-month reserve has been secured for the site prior to the City assuming maintenance responsibilities. A site will not be granted the Start of the 1 Year Maintenance Period if there is not adequate funding for the City to assume maintenance responsibilities the following year.**
 - **Inspection #5 (Turn-Over)** – On or about the one-year anniversary of Inspection #4, Developer shall call for an inspection to allow the City to review and identify any potential irrigation system defects, dead plants, weed, debris or graffiti; stressed, diseased, or dead trees; mulch condition, hardscape or other concerns with the landscape installation; or to accept final turn over of the landscape installation. At his sole expense, the Developer shall be responsible for rectifying system and installation deficiencies, and the one-year maintenance period shall be extended by the City until all deficiencies are cured to the satisfaction of the City. If in the opinion of the City’s Landscape Inspector the landscape installation is in substantial compliance with the approved landscaping plans, the irrigation and communication system is functioning as intended, and the landscape installation is found to be acceptable to the City, then the Inspector shall recommend to the City’s



CITY OF PERRIS

PUBLIC WORKS DEPARTMENT

Special District Coordinator to accept turn-over of water and electrical accounts, wi-fi communication contracts and the entire landscape installation.

5. **One Year Maintenance and Plant Establishment Period** - The applicant will be required to provide a minimum of a one (1) year maintenance and plant establishment period, paid at the sole expense of applicant. This one-year maintenance period commences upon the successful completion of Inspection #4 discussed above, and final approval by the City. During this one-year period the applicant shall be required to maintain all landscape areas free of weeds, debris, trash, and graffiti; and keep all plants, trees, and shrubs in a viable growth condition. Prior to the start of the one-year maintenance period, the Developer shall submit a weekly Landscape Maintenance Schedule for review and approval by the City's Special Districts Division. The City shall perform periodic site inspections during the one-year maintenance period. The purpose of these periodic inspections is to identify any and all items needing correction prior to acceptance by the City at the conclusion of the one-year maintenance period. Said items needing correction may include but are not limited to replacement of dead or diseased plant materials, weeding, replenishment of mulches, repair of damaged or non-functioning irrigation components, test of irrigation controller communications, etc. During this period, the City shall begin the annual assessment of the benefit zone in preparation for the landscape installation turnover to City maintenance staff.

6. **Street/Off-Site Improvements.** The applicant shall submit street improvement plans, accompanied by the appropriate filing fee to the City Engineering Department. Details of treatments off-site improvements, including lighting, shall meet both the City Engineer's Design Guidelines, and the additional requirements of the Special Districts Division. Components shall include, but not be limited to:
 - a. **Street Lighting**-If Street lighting is required, lighting shall meet the type, style, color, and durability requirements necessary for energy efficiency goals, maintenance, and longevity of improvements of the City Engineer's Office. Streetlights will be owned by City of Perris not SCE. Streetlights shall be constructed per LS-3 account billing standard, which shall include an individually metered pedestal for streetlights.
 - b. **Acceptance By Public Works/Special Districts**- Lighting District facilities required by the City Engineer's Office shall be installed and fully operational and approved by final inspection by the City Engineer's Office, and the City's Consulting Traffic Signal Inspection Team (Riverside County TLMA) at (951) 955-6815. Prior to acceptance for maintenance of



CITY OF PERRIS

PUBLIC WORKS DEPARTMENT

“Off-site” traffic signal and lighting facilities by the Public Works-Special Districts, the developer shall contact the Public Works Special Districts Division at (951) 657-3280 to schedule the delivery of all required turn-over submittal items. Prior to acceptance into Lighting District 84-1, coordinate turnover information pertaining to Street Lights, and Traffic Signal Electrical/SCE Service Meters with Wildan Financial Services, the City’s Special Districts Consulting Firm at (951) 587-3564. (i.e. Provide electrical meter number, photo of pedestal, and coordinate “request for transfer of billing information” with SCE and City for all new service meters). Developers shall pay 18-month energy charges to the City of Perris for all off-site street lighting. Call Wildan Financial Services, Inc. for the amount due, and to obtain receipt for payment. Obtain and provide a clearance form from Riverside County TLMA indicating completion of all punch list items from traffic signal construction. Submit one large format photocopy of Traffic Signal as-built plans and timing sheets.

7. **Water Quality Management Plans.** The applicant shall submit a Preliminary and Final WQMP, accompanied by the appropriate filing fee to the Planning Department and City Engineering Department, respectively. Details for treatment control facilities shall meet both the Riverside County WQMP Design Guidelines, and the additional requirements of the Special Districts Division intended to reduce long term maintenance costs and longevity of improvements. Components shall include, but not be limited to:
 - **Storm Drain Screens-**If off-site catch basins are required by the City Engineer’s Office, connector pipe screens shall be included in new catch basins to reduce sediment and trash loading within storm pipe. Connector pipe screens shall meet the type, style, and durability requirements of the Public Work’s Special Districts Division.
 - **WQMP Inspections-** The project applicant shall inform the on-site project manager and the water quality/utilities contractor of their responsibility to call for both “ON-SITE” and OFF-SITE” WQMP Inspections at the appropriate stages of construction. Contact CGRM at (909) 455-8520 to schedule inspections.
 - **Acceptance By Public Works/Special Districts-**Both on-site and off-site flood control/water quality facilities required for the project, as depicted in the Final WQMP, shall be installed and fully operational, and approved by final inspection by the City’s WQMP Consultant, CGRM. The Developer shall obtain a final Clearance Letter from CGRM indicating compliance with all applicable Conditions of Approval for the approved WQMP. The



CITY OF PERRIS

PUBLIC WORKS DEPARTMENT

developer shall deliver the same to the Public Works-Special Districts. In addition, prior to acceptance by the City, the developer shall submit a Covenant and Agreement describing on-going maintenance responsibilities for on-site facilities per the approved WQMP, to the Public Works Special Districts Division. The Public Works Special Districts Division will review and approve the Covenant and Agreement. The City shall record the same with the Riverside County Recorder's Office, and the recorded instrument shall be returned to the City Clerk of the City of Perris for filing.

8. **Flood Control District #1 Maintenance Acceptance.** Flood Control District facilities required by the City Engineer's Office shall be installed and fully operational, and approved by final inspection by the City Engineer's Office. Prior to acceptance for maintenance of "Off-site" flood control facilities by the Public Works-Special Districts the developer shall contact the Public Works Special Districts Division at (951) 657-3280 to schedule the delivery of all required turn-over submittal items including as-built storm drain plans in electronic PDF format, one large format photo-copy of as-built plans, storm drain video report in electronic format, and hardcopy of video report with industry standard notations and still photos made during video runs (i.e. facilities sizes, off-sets or damage, facility type, dirt and debris, etc.). The flood control facilities shall be turned over in a condition acceptable to the City, and the developer shall make all necessary repairs and perform initial maintenance to the satisfaction of the City.

9. (A.) **Assessment Districts. Prior to issuance of Grading Permit, issuance of Building Permit, or Final Map Recordation, whichever occurs first,** the developer shall **complete annexation** into the special districts, posting an adequate maintenance performance bond to be retained by the City as required by the Public Works Department. The applicant shall deposit \$5,250 per district, \$15,750 total due. Payment is to be made to the City of Perris, and the check delivered to the City Engineer's Office. Upon receipt of deposit and Consent and Waiver Forms, the developer shall work with City to meet all required milestones for annexations. Payment shall be accompanied by the appropriate document for each district indicating intent and understanding of annexation, to be notarized by property owner(s):
 - *Consent and Waiver for Maintenance District No. 84-1 - New Street* lighting proposed by the project, as determined by the City Engineer



CITY OF PERRIS

PUBLIC WORKS DEPARTMENT

- ***Consent and Waiver for Landscape Maintenance District No. 1*** – New off-site parkway landscape proposed by the project on Nuevo Road and Wilson Ave and pay their fair share of the Nuevo Road Median.
- ***Petition for Flood Control Maintenance District No. 1*** - New Off-site Flood Control Facilities proposed by the project, as determined by the City Engineer.
- Original notarized document(s) to be sent to:
Daniel Louie
Wildan Financial Services
27368 Via Industria, #200
Temecula, CA 92590
- i. City prepares the Engineer’s Reports which includes a description of the improvements to be maintained, an annual cost estimate and annual assessment amounts.
- ii. Reports are reviewed and approved by the property owner. The assessment ballots will be based on the Reports.
- iii. The Reports and corresponding resolutions are placed, for approval, on the City Council Meeting Agenda. City Council action will include ordering the assessment ballots and setting a Public Hearing for no sooner than 45 days. Property owner attendance at this City Council Meeting is not required.
- iv. The assessment ballots are sent to the property owner and are opened by the City Clerk at the close of the Public Hearing. With a “YES” vote by the property owner the City Council can move forward with the Resolution that Confirms the Annexation. Property owner attendance at this Public Hearing is not required.
- v. Confirmation by the City Council completes the annexation process, and the condition of approval has been met.

(B.) Community Facilities Districts. Prior to issuance of Grading Permit, issuance of Building Permit, or Final Map Recordation, whichever occurs first, the developer shall **complete annexation** into any community facilities or similar district that provides funding for maintenance, services, or public improvements that benefit the project or provision shall be made satisfactory to the

Page 9 of 10



CITY OF PERRIS

PUBLIC WORKS DEPARTMENT

City for providing these services in the applicable district. The cost and benefits shall be described in the applicable district and annexation documents. In addition to districts that exist as of the date of project approval, this condition shall include later-formed districts provided that such districts are in existence as of the time of issuance of any grading permit or building permit for the project, as applicable. Such districts may include but are not limited to the following:

- *Perris Community Facilities District; and*
- *Any other applicable Community Facilities District*

10. **Prior to Certificate of Occupancy.** The issuance of occupancy certificate(s) is **stringent** upon meeting the Conditions of Approval set forth by Public Works. The following should be understood by Developer:

- a. Issuance of First Certificate of Occupancy, temporary or final, whichever occurs first:
 - i. May only be permitted if Developer has completed annexations into aforementioned districts of Condition 9(A) and 9(B).
- b. Issuance of Final Certificate of Occupancy of more than **50% of total dwelling units**
 - i. Upon no Public Works corrections at completion of Condition 4: Landscape Inspection #3, and
 - ii. Completion of Conditions 1 through 3, and 6 through 9.
- c. Issuance of Final Certificate of Occupancy of more than **90% of total dwelling units**
 - i. May only be permitted after Developer has met the aforementioned stipulations of Condition 10(b), and completed Condition 4: Landscape Inspection #4 with no outstanding corrections.



CITY OF PERRIS
COMMUNITY SERVICES

MEMO

Date: April 9, 2025

To: Nathan Perez, Project Planner

From: Sabrina Chavez, Director of Public Services

Cc: Arcenio Ramirez, Director of Community Services
Arturo Garcia, Parks Manager
Martin Martinez, Management Analyst

Subject: General Plan Amendment (GPA) 23-05247, Zone Change (ZC) 23-05245, Planned Development Overlay (PDO) 23-05246, and Tentative Tract Map 23-05244 (TPM 38775) - A proposal to construct 141 townhomes and amenities on 11.62 acres located at the southeast corner of Nuevo Road and Wilson Avenue in the R-6,000 zone.

Public Services Staff reviewed the project application in subject, and since the project includes a Planned Development Overlay (PDO) for a new residential community, the project is subject to Planning Department PDO development standards requiring recreation amenities. Therefore, we offer the following condition(s):

Development Impact Fees

- The Project is subject to payment of Industrial Park Development Impact Fees.
- The Project is subject to payment of Residential Park Development Impact Fees.
- This Project is subject to payment of Public Art Development Impact Fees.

Special Districts

- The project shall annex into the Community Facilities District No. 2018-02 (Public Services)

SRC COMMENTS
***** BUILDING & SAFETY *****

Planning Case File No(s): TTM 23-05244, GPA 23-05247, ZC 23-05245 & PDO 23-05246

Case Planner: Nathan Perez (951) 943-5003, ext. 279

Applicant: Ryan Woosley

Location:
Southwest corner of Nuevo Road and Wilson Ave.

Project:
A proposal to construct 145 Townhouses and amenities and for a GPA, ZC, PDO and TTM

APN(s):

Reviewed By: David J. Martinez, CBO

Date: 10-16-2023

BUILDING & SAFETY

GENERAL CONDITIONS

- 1. Shall comply with the latest adopted edition of the following California Codes as applicable:
 - A. 2022 California Building Code
 - B. 2022 California Residential Code
 - C. 2022 California Electrical Code
 - D. 2022 California Mechanical Code
 - E. 2022 California Plumbing Code
 - F. 2022 California Energy Code.
 - G. 2022 California Fire Code
 - H. 2022 California Green Building Standards Code.
 - I. 2022 Accessibility Regulations
- 2. The Tract or Parcel map shall record prior to the issuance of any permits
- 3. Permits are required prior to the removal and/or demolition of structures.
- 4. You will have to comply with the new residential Solar regulations.
- 5. You will have to comply with the new EV charging station regulations
- 6. If you are proposing to utilize Private streets instead of public streets you will have to comply with the private street limited street parking requirements and restricted parking for fire access requirements.
- 7. Riverside County Health Departments review, and approval is required for the pool and for the

rec buildings.

8. The recreational areas, pool and club house all will be required to comply with the State of California Title 24 Access regulations and with the ADA Access regulations.

PRIOR TO ISSUANCE OF BUILDING/CONSTRUCTION PERMITS

14. The following items shall be completed and/or submitted as applicable – prior to the issuance of building permits for this project:
- A. Precise grading plans shall be approved
 - B. Rough grading completed
 - C. Compaction certification
 - D. Pad elevation certification
 - E. Rough grade inspection signed off

FIRE COMMENTS: WILL BE PROVIDED BY DENNIS GRUBB AND ASSOCIATES

Exhibit B

Location/Aerial Map

Vicinity Map



7/30/2025, 1:25:14 PM

- Parcels
-  Perris Boundary
- Roads Labeling

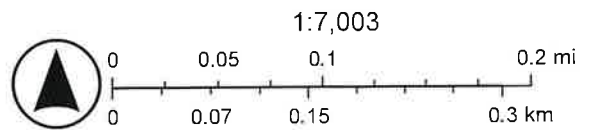

Nearmap

Exhibit C

Existing and Proposed General Plan Map

Existing Land Use Map

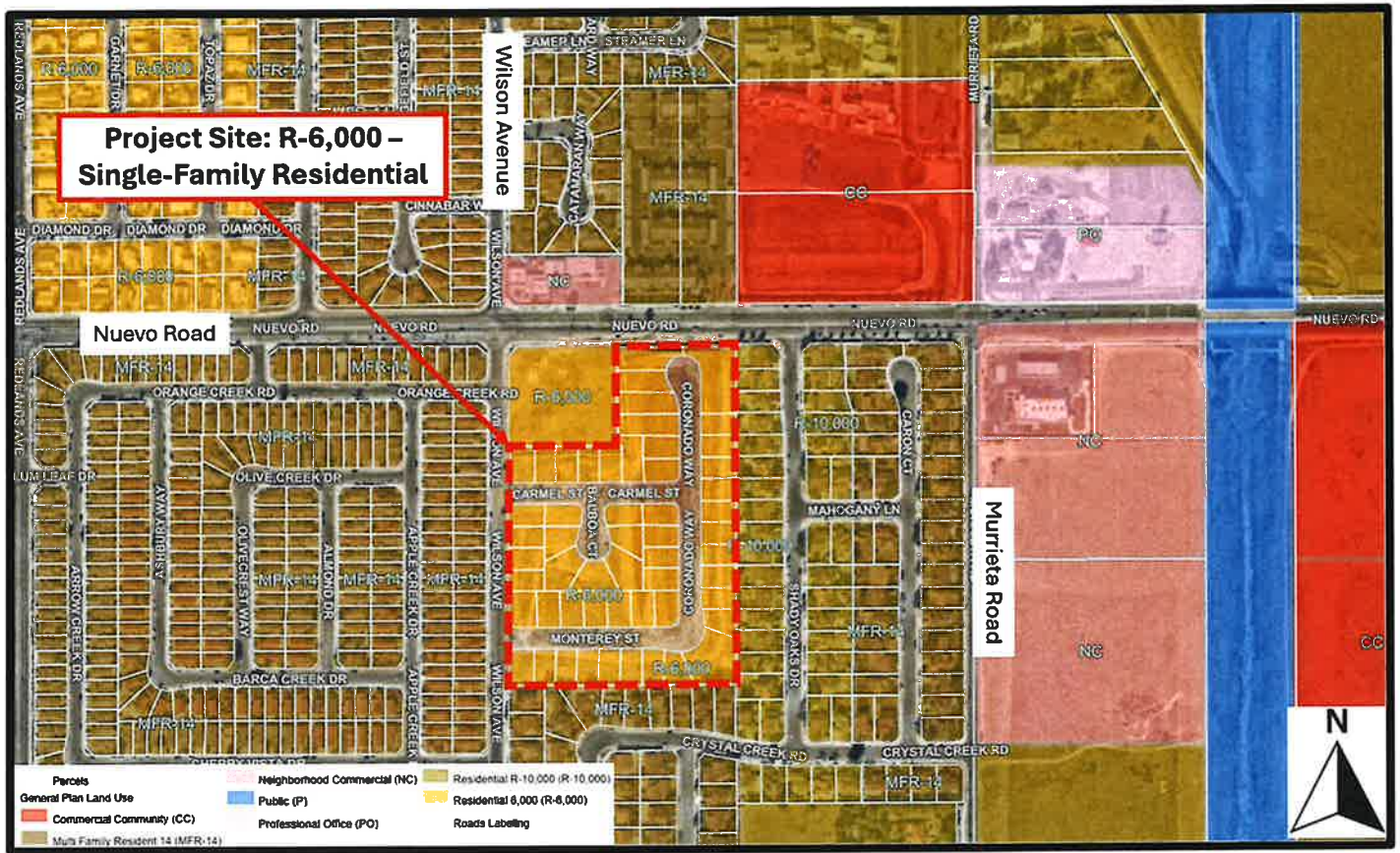

Proposed Land Use Map

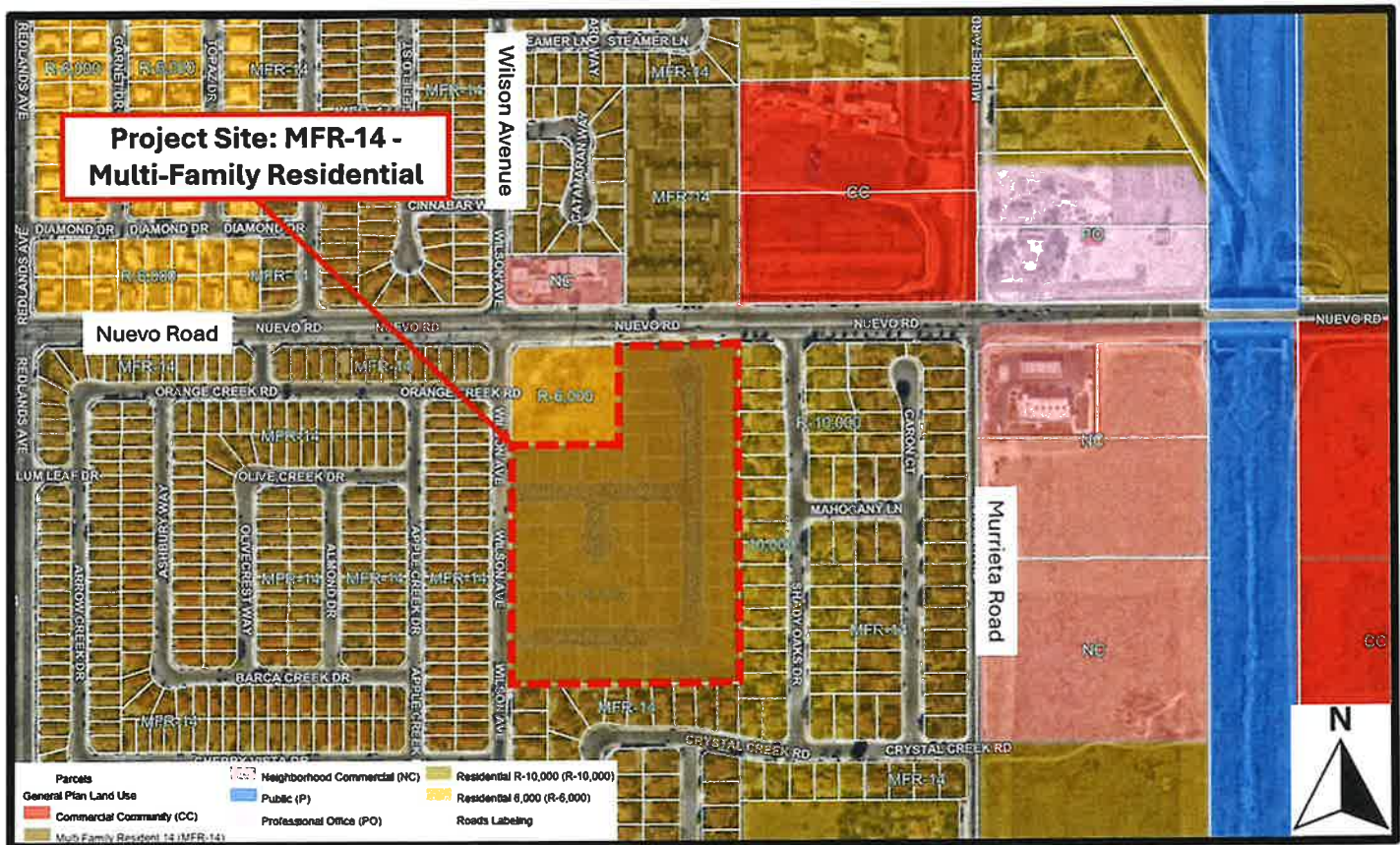

Exhibit D

Existing and Proposed Zoning Map (PDO Zone)

Exhibit E

MARB/IPA ALUCP Map

MARB/IPA ALUCP Map

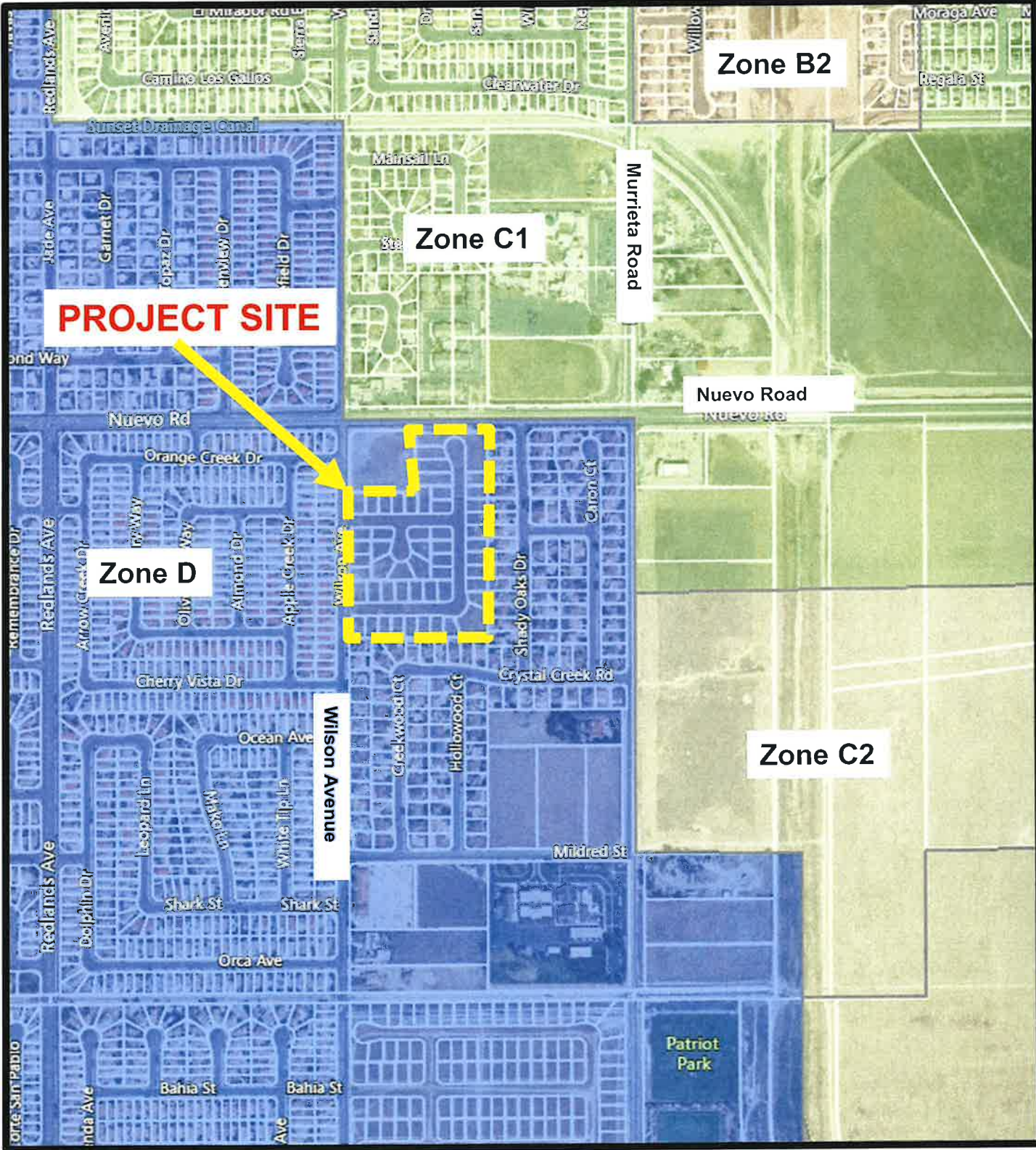

Parcels
Perris Boundary



Exhibit F

Project Plans (Site Plan, Building Elevations, Renderings, Floor Plans, Landscape Plans, and Wall/Fence Plans)

Due to the size of the files, Project Plans (Site Plan, Building Elevations, Renderings, Floor Plans, Landscape Plans, Wall and Fence Plans, Color and Material Sample Sheet, etc.) are available online at:

https://www.cityofperris.org/departments/development-services/planning/environmental-documents-for-public-review/-folder-517#docan1206_1313_479



View from Wilson Avenue

ACACIA POINTE

PERRIS, CA

R.1

WHA

DESIGN REVIEW

© 2021 WALSH GROUP, INC. ALL RIGHTS RESERVED | 2021289 | 07-22-25

Note: Artist's Conception; Colors, Materials and Application May Vary.

PERHORN INC.
America's Builder



PLAN 3A

LEFT



PLAN 3A

PLAN 1A

PLAN 2A-R

FRONT



PLAN 2A-R

RIGHT



PLAN 2A-R

PLAN 1A

PLAN 3A

REAR

STYLE ELEMENTS: SPANISH

- Concrete Low 'S' Tile
- Stucco with 16/20 Finish
- Foam Shutters
- Stucco Wrapped Polished with Brackets
- Stucco Wrapped Shaped Corbels
- Gable End Wrought Iron Detail
- Windows with Divided Lights
- Stucco Wrapped Trim
- Stucco Wrapped Column
- Solid Panel Entry Door
- Sectional Decorative Garage Door with Windows
- Decorative Tile
- Wrought Iron Pot Shelf

TOWNHOMES | BUILDING 300A
Spanish Elevations (Elevation A)



ACACIA POINTE

PERRIS, CA

Note: Artist's Conception, Colors, Materials And Application May Vary.

1.7
 SCALE 3/16" = 1'-0" 0 3 6 12
 DESIGN REVIEW
 2021.2.29 | 07-22-25





Plan 3B

LEFT



Plan 3

Plan 1B

Plan 2B-R

FRONT



Plan 2B-R

RIGHT



Plan 2B-R

Plan 1B

Plan 3B

REAR

STYLE ELEMENTS: ITALIANATE

- Concrete Low 'S' Tile
- Stucco with 16/20 Finish
- Foam Shutters
- Stucco Wrapped Pots/Shell with Brackets
- Stucco Wrapped Shaped Cornels
- Stucco Wrapped Cornice Trim
- Windows with Divided Lights
- Stucco Wrapped Trim
- Stucco Wrapped Column
- Solid Panel Entry Door
- Sectional Decorative Garage Door with Windows
- Stone Veneer Wainscot

TOWNHOMES | BUILDING 300B
Italianate Elevations (Elevation B)

ACACIA POINTE

PERRIS, CA



Note: Artist's Conception; Colors, Materials And Application May Vary

SCALE: 3/16" = 1'-0" 0 3 6 12
1.8
WHA
 DESIGN REVIEW
 © 2022 WEAVER CONSULTANTS, INC. | 2021239 | 07-22-25



Front

Right



Rear

Left

POOL BUILDING
Building Elevations

ACACIA POINTE

PERRIS, CA

Note: Artist's Conception; Colors, Materials And Application May Vary.

EXPRESS

D.R. HOUBIN
America's Builder

3.8

WHA

DESIGN REVIEW
2021239 | 07-22-25

© 2025 WILSON JONES ARCHITECTS, INC. ALL RIGHTS RESERVED

ACACIA (TR 38775)

WALL & FENCE DETAILS



- LEGEND**
1. BRICK/BLACK WALL COLUMN
 2. FOOTING - PER STRUCTURAL ENGINEER'S REQUIREMENTS
 3. PRECASTER WALLS

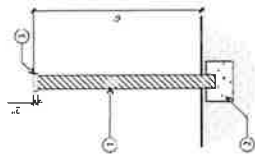

NON-RETAINING

- A** BLOCK WALL

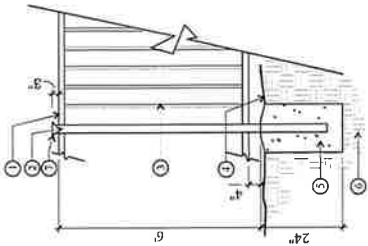

LEGEND

1. 1-1/2" x 1" TOP & BOTTOM RAIL
 2. 1-1/2" SQ. TUBULAR STEEL POST @ 6' O.C. MAXIMUM
 3. 3/8" SQ. PICKETS @ 3-1/2" O.C.
 4. FINISH GRADE
 5. 12" DIA. CONCRETE FOOTING SLOPE TO DRAIN
 6. 90% COMPACTED SUBGRADE
 7. 2-1/2" SQ. TUBULAR STEEL CAP
- REFER TO CONSTRUCTION PLAN FOR LOCATIONS
- STEEL NOTES**
- A. PAINT - ALL TUBULAR STEEL SHALL RECEIVE (2) COATS RUST INHIBITIVE PRIMER
 - B. GRIND ALL WELDS SMOOTH
 - C. PAINT TO BE VERIFIED WITH BUILDER PRIOR TO START OF CONSTRUCTION

C TUBULAR STEEL FENCE

- B** WALL W/ CAP

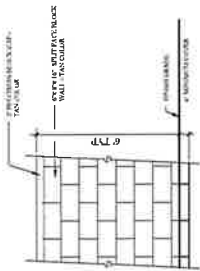

NON-RETAINING

- A** BLOCK WALL

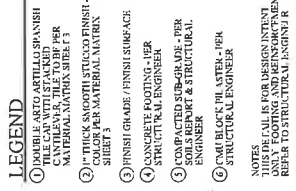

LEGEND

1. DOUBLE ARTO ARTILLO SPANISH TILE CAP WITH FINISH PER MATERIAL MANUFACTURER'S SPECIFICATIONS
2. 1" THICK SMOOTH STUCCO FINISH - SHEET 3
3. FINISH GRADE / FINISH SURFACE
4. CONCRETE FOOTING - PER STRUCTURAL ENGINEER
5. COMPACTED SUB-GRADE - PER ENGINEER, MECHANICAL & STRUCTURAL
6. GALV. BARS IN STEEL PER STRUCTURAL ENGINEER

NOTES

- A. ALL REINFORCEMENT SHALL BE INSTALLED IN ACCORDANCE WITH THE REQUIREMENTS OF THE STRUCTURAL ENGINEER

- D** PILASTERS



- LEGEND**
1. MONUMENT WALL CAP
 2. MONUMENT WALL
 3. MONUMENT WALL COLUMN
 4. MONUMENT WALL
 5. MONUMENT WALL
 6. MONUMENT WALL
 7. MONUMENT WALL
 8. MONUMENT WALL
 9. MONUMENT WALL
 10. MONUMENT WALL
 11. MONUMENT WALL
 12. MONUMENT WALL
 13. MONUMENT WALL
 14. MONUMENT WALL
 15. MONUMENT WALL
 16. MONUMENT WALL
 17. MONUMENT WALL
 18. MONUMENT WALL
 19. MONUMENT WALL
 20. MONUMENT WALL
 21. MONUMENT WALL
 22. MONUMENT WALL
 23. MONUMENT WALL
 24. MONUMENT WALL
 25. MONUMENT WALL
 26. MONUMENT WALL
 27. MONUMENT WALL
 28. MONUMENT WALL
 29. MONUMENT WALL
 30. MONUMENT WALL
 31. MONUMENT WALL
 32. MONUMENT WALL
 33. MONUMENT WALL
 34. MONUMENT WALL
 35. MONUMENT WALL
 36. MONUMENT WALL
 37. MONUMENT WALL
 38. MONUMENT WALL
 39. MONUMENT WALL
 40. MONUMENT WALL
 41. MONUMENT WALL
 42. MONUMENT WALL
 43. MONUMENT WALL
 44. MONUMENT WALL
 45. MONUMENT WALL
 46. MONUMENT WALL
 47. MONUMENT WALL
 48. MONUMENT WALL
 49. MONUMENT WALL
 50. MONUMENT WALL
 51. MONUMENT WALL
 52. MONUMENT WALL
 53. MONUMENT WALL
 54. MONUMENT WALL
 55. MONUMENT WALL
 56. MONUMENT WALL
 57. MONUMENT WALL
 58. MONUMENT WALL
 59. MONUMENT WALL
 60. MONUMENT WALL
 61. MONUMENT WALL
 62. MONUMENT WALL
 63. MONUMENT WALL
 64. MONUMENT WALL
 65. MONUMENT WALL
 66. MONUMENT WALL
 67. MONUMENT WALL
 68. MONUMENT WALL
 69. MONUMENT WALL
 70. MONUMENT WALL
 71. MONUMENT WALL
 72. MONUMENT WALL
 73. MONUMENT WALL
 74. MONUMENT WALL
 75. MONUMENT WALL
 76. MONUMENT WALL
 77. MONUMENT WALL
 78. MONUMENT WALL
 79. MONUMENT WALL
 80. MONUMENT WALL
 81. MONUMENT WALL
 82. MONUMENT WALL
 83. MONUMENT WALL
 84. MONUMENT WALL
 85. MONUMENT WALL
 86. MONUMENT WALL
 87. MONUMENT WALL
 88. MONUMENT WALL
 89. MONUMENT WALL
 90. MONUMENT WALL
 91. MONUMENT WALL
 92. MONUMENT WALL
 93. MONUMENT WALL
 94. MONUMENT WALL
 95. MONUMENT WALL
 96. MONUMENT WALL
 97. MONUMENT WALL
 98. MONUMENT WALL
 99. MONUMENT WALL
 100. MONUMENT WALL

- E** ENTRY MONUMENT



- F** DOG PARK FENCE

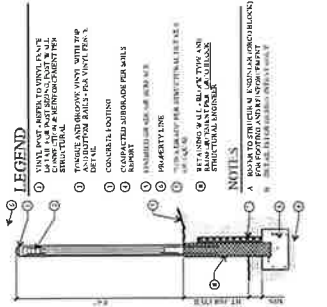

LEGEND

1. VINYL POST AND RAIL TO VINYL FENCE
2. VINYL POST AND RAIL TO VINYL FENCE
3. VINYL POST AND RAIL TO VINYL FENCE
4. VINYL POST AND RAIL TO VINYL FENCE
5. VINYL POST AND RAIL TO VINYL FENCE
6. VINYL POST AND RAIL TO VINYL FENCE
7. VINYL POST AND RAIL TO VINYL FENCE
8. VINYL POST AND RAIL TO VINYL FENCE
9. VINYL POST AND RAIL TO VINYL FENCE
10. VINYL POST AND RAIL TO VINYL FENCE
11. VINYL POST AND RAIL TO VINYL FENCE
12. VINYL POST AND RAIL TO VINYL FENCE
13. VINYL POST AND RAIL TO VINYL FENCE
14. VINYL POST AND RAIL TO VINYL FENCE
15. VINYL POST AND RAIL TO VINYL FENCE
16. VINYL POST AND RAIL TO VINYL FENCE
17. VINYL POST AND RAIL TO VINYL FENCE
18. VINYL POST AND RAIL TO VINYL FENCE
19. VINYL POST AND RAIL TO VINYL FENCE
20. VINYL POST AND RAIL TO VINYL FENCE
21. VINYL POST AND RAIL TO VINYL FENCE
22. VINYL POST AND RAIL TO VINYL FENCE
23. VINYL POST AND RAIL TO VINYL FENCE
24. VINYL POST AND RAIL TO VINYL FENCE
25. VINYL POST AND RAIL TO VINYL FENCE
26. VINYL POST AND RAIL TO VINYL FENCE
27. VINYL POST AND RAIL TO VINYL FENCE
28. VINYL POST AND RAIL TO VINYL FENCE
29. VINYL POST AND RAIL TO VINYL FENCE
30. VINYL POST AND RAIL TO VINYL FENCE
31. VINYL POST AND RAIL TO VINYL FENCE
32. VINYL POST AND RAIL TO VINYL FENCE
33. VINYL POST AND RAIL TO VINYL FENCE
34. VINYL POST AND RAIL TO VINYL FENCE
35. VINYL POST AND RAIL TO VINYL FENCE
36. VINYL POST AND RAIL TO VINYL FENCE
37. VINYL POST AND RAIL TO VINYL FENCE
38. VINYL POST AND RAIL TO VINYL FENCE
39. VINYL POST AND RAIL TO VINYL FENCE
40. VINYL POST AND RAIL TO VINYL FENCE
41. VINYL POST AND RAIL TO VINYL FENCE
42. VINYL POST AND RAIL TO VINYL FENCE
43. VINYL POST AND RAIL TO VINYL FENCE
44. VINYL POST AND RAIL TO VINYL FENCE
45. VINYL POST AND RAIL TO VINYL FENCE
46. VINYL POST AND RAIL TO VINYL FENCE
47. VINYL POST AND RAIL TO VINYL FENCE
48. VINYL POST AND RAIL TO VINYL FENCE
49. VINYL POST AND RAIL TO VINYL FENCE
50. VINYL POST AND RAIL TO VINYL FENCE
51. VINYL POST AND RAIL TO VINYL FENCE
52. VINYL POST AND RAIL TO VINYL FENCE
53. VINYL POST AND RAIL TO VINYL FENCE
54. VINYL POST AND RAIL TO VINYL FENCE
55. VINYL POST AND RAIL TO VINYL FENCE
56. VINYL POST AND RAIL TO VINYL FENCE
57. VINYL POST AND RAIL TO VINYL FENCE
58. VINYL POST AND RAIL TO VINYL FENCE
59. VINYL POST AND RAIL TO VINYL FENCE
60. VINYL POST AND RAIL TO VINYL FENCE
61. VINYL POST AND RAIL TO VINYL FENCE
62. VINYL POST AND RAIL TO VINYL FENCE
63. VINYL POST AND RAIL TO VINYL FENCE
64. VINYL POST AND RAIL TO VINYL FENCE
65. VINYL POST AND RAIL TO VINYL FENCE
66. VINYL POST AND RAIL TO VINYL FENCE
67. VINYL POST AND RAIL TO VINYL FENCE
68. VINYL POST AND RAIL TO VINYL FENCE
69. VINYL POST AND RAIL TO VINYL FENCE
70. VINYL POST AND RAIL TO VINYL FENCE
71. VINYL POST AND RAIL TO VINYL FENCE
72. VINYL POST AND RAIL TO VINYL FENCE
73. VINYL POST AND RAIL TO VINYL FENCE
74. VINYL POST AND RAIL TO VINYL FENCE
75. VINYL POST AND RAIL TO VINYL FENCE
76. VINYL POST AND RAIL TO VINYL FENCE
77. VINYL POST AND RAIL TO VINYL FENCE
78. VINYL POST AND RAIL TO VINYL FENCE
79. VINYL POST AND RAIL TO VINYL FENCE
80. VINYL POST AND RAIL TO VINYL FENCE
81. VINYL POST AND RAIL TO VINYL FENCE
82. VINYL POST AND RAIL TO VINYL FENCE
83. VINYL POST AND RAIL TO VINYL FENCE
84. VINYL POST AND RAIL TO VINYL FENCE
85. VINYL POST AND RAIL TO VINYL FENCE
86. VINYL POST AND RAIL TO VINYL FENCE
87. VINYL POST AND RAIL TO VINYL FENCE
88. VINYL POST AND RAIL TO VINYL FENCE
89. VINYL POST AND RAIL TO VINYL FENCE
90. VINYL POST AND RAIL TO VINYL FENCE
91. VINYL POST AND RAIL TO VINYL FENCE
92. VINYL POST AND RAIL TO VINYL FENCE
93. VINYL POST AND RAIL TO VINYL FENCE
94. VINYL POST AND RAIL TO VINYL FENCE
95. VINYL POST AND RAIL TO VINYL FENCE
96. VINYL POST AND RAIL TO VINYL FENCE
97. VINYL POST AND RAIL TO VINYL FENCE
98. VINYL POST AND RAIL TO VINYL FENCE
99. VINYL POST AND RAIL TO VINYL FENCE
100. VINYL POST AND RAIL TO VINYL FENCE

NOTES

- A. ALL REINFORCEMENT SHALL BE INSTALLED IN ACCORDANCE WITH THE REQUIREMENTS OF THE STRUCTURAL ENGINEER

- G** VINYL FENCE / RET'G WALL



- E** ENTRY MONUMENT

Exhibit G

Tentative Tract Map No. 38775

Exhibit H

Planning Commission Staff Report Without Exhibits – Dated 5/7/2025.

Due to the size of the files, only the staff report is included as a hard copy. The staff report and exhibits are available online at:

https://www.cityofperris.org/departments/development-services/planning/environmental-documents-for-public-review/-folder-517#docan1206_1313_479



CITY OF PERRIS

PLANNING COMMISSION

AGENDA SUBMITTAL

MEETING DATE: May 7, 2025

SUBJECT: General Plan Amendment (GPA) 23-05247, Zone Change (ZC) 23-05245, Planned Development Overlay (PDO) Zone 23-05246, Tentative Tract Map 23-05244 (TTM 38775), Development Plan Review (DPR) 23-00019 – A proposal to consider the following entitlements to facilitate the construction of 141 townhome-style condominiums and amenities on 11.6 acres, located south of Nuevo Road and east of Wilson Avenue: 1) General Plan Amendment and Zone Change to change the land use designation of 11.6 acres from R-6,000 – Single Family Residential to MFR-14 – Multiple Family Residential; 2) Planned Development Overlay to allow flexibility from the MFR-14 development standards; 3) Tentative Tract Map to consolidate 57 parcels into one condominium lot and two lettered lots; and 4) Development Plan Review for review of the site plan and building elevations. Applicant: Ryan Woosley, D.R. Horton

REQUESTED ACTION: Adopt Resolution No. 25-07 recommending that the City Council adopt Mitigated Negative Declaration No. 2403 and the Mitigation Monitoring and Reporting Program and approve the General Plan Amendment (GPA) 23-05247, Zone Change (ZC) 23-05245, Planned Development Overlay (PDO) Zone 23-05246, Tentative Tract Map 23-05244 (TTM 38775), Development Plan Review (DPR) 23-00019 based on the findings contained in the Resolution and subject to the Conditions of Approval.

CONTACT: Patricia Brenes, Planning Manager

BACKGROUND

The 11.62-acre project site consists of a vacant 57-lot residential subdivision (Tract Map 31651) approved by the City Council in 2004, which is proposed to be developed with 141 townhome units. These parcels are located south of Nuevo Road and east of Wilson Avenue. The project site is surrounded by residences to the east and south; residences across Wilson Avenue and a vacant parcel zoned Professional Office to the west; and Providence Perris apartments and a shopping center across Nuevo Road, and a vacant parcel zoned Professional Office to the north.

PROJECT DESCRIPTION

The applicant is requesting approval of a General Plan Amendment, Zone Change, Planned Development Overlay, Tentative Tract Map, and Development Plan Review to construct 141-unit

townhome-style condominiums, drainage basins, and associated amenities on 11.6 acres, yielding a density of 13.7 units per acre.

The proposed condominium development comprises 34 detached two-story buildings, including 7 three-plex buildings, 15 four-plex buildings, and 12 five-plex buildings, designed in traditional Spanish and Italianate architecture. Each residential building includes three floor plans with three and four bedrooms, ranging in size from 1,600 to 1,652 square feet. Each unit includes a kitchen, living room, dining room, bedrooms, bathrooms, laundry room, private open space, and a two-car garage. Amenities include a 766-square-foot single-story pool building, pickleball courts, bocce courts, a swimming pool, a tot lot, seating, and open space areas. The project will also feature two drainage basins designated as Lots A and B.

Access is provided along Wilson Avenue. Primary vehicular access is provided via the northerly driveway, and secondary access for emergency vehicles is provided via the southerly driveway. A pedestrian gate is provided on one side of the main entry. Guest parking is proposed throughout the development. The development is proposed to be gated and secured with masonry walls, tubular steel, and vinyl fencing.

To facilitate this project, the following entitlements are requested:

1. General Plan Amendment: To change the land use designation of 11.62 acres from R-6,000-Single-Family Residential to MFR-14-Multi-Family Residential to increase the density to 14 dwelling units per acre.
2. Zone Change and Planned Development Overlay: To rezone 11.62 acres from R-6,000-Single-Family Residential Zone to MFR-14-PDO - Multi-Family Residential—Planned Development Overlay Zone to increase the residential density to 14 dwelling units per acre and allow flexibility in the development standards.
3. Tentative Tract Map: To subdivide 57 vacant parcels totaling 11.62 acres into a 10.29-acre condominium parcel, a 0.72-acre Lot A, and a 0.61-acre Lot B.
4. Development Plan Review: To review the site plan and building elevations.

PROJECT ANALYSIS

The table below summarizes the project's consistency with the General Plan, Title 19 - Zoning Code, Title 18 - Subdivisions Code, and the 2014 March Air Reserve Base/Inland Port Airport Land Use Compatibility Plan.

CONSISTENCY TABLE
<p>Consistency with the General Plan</p> <p>The General Plan land use designation of the 11.62-acre project site is proposed to be amended from R-6,000-Single-Family Residential Zone to MFR-14-Multi-Family Residential, as the MFR-14 designation is intended for apartments, townhomes, and condominiums at a density of 7 to 14 dwellings per acre. The project proposes townhome-style condominiums at a density of 13.7 dwelling units per acre, consistent with the proposed MFR-14 land use designation.</p> <p>Subject to the approval of the GPA, the Project will be consistent with the General Plan and will further the following General Plan Safety Element, Circulation Element, and Housing Element goals:</p>

CONSISTENCY TABLE

➤ Safety Element:

Policy S-2.1 – Require road upgrades as part of new developments/major remodels to ensure adequate evacuation and emergency vehicle access. Limit improvements for existing building sites to property frontages.

Policy S-6.1 – Ensure new development complies with the development requirements of the AICUZ (Air Installation Compatibility Use Zones) Land Use Compatibility Guidelines and ALUP (Airport Land Use Plan) Airport Influence Areas for March Air Reserve Base.

➤ Circulation Element:

Policy IV.A - Provide non-motorized alternatives for commuter travel as well as recreational opportunities that maximize safety and minimize potential conflicts with pedestrians and motor vehicles.

➤ Housing Element:

Policy 1.2: - Promote development within the City that provides a variety of housing types and densities based on the suitability of the land, including the availability of infrastructure, the provision of adequate services, and recognition of environmental constraints.

Consistency with Title 19 - Zoning Code

The project proposes to rezone the 11.62-acre site from R-6,000-Single-Family Residential Zone to MFR-14-PDO - Multi-Family Residential - Planned Development Overlay Zone. The MFR 14 Zone is intended for attached or detached medium-density residential development such as duplexes, condominiums, and townhomes at a density of 7-14 dwellings per acre, and the application of the PDO Zone allows flexibility from the development standards, in exchange for superior architecture, site design, and amenities.

The project proposes townhome-style condominiums at a density of 13.7 dwelling units per acre, consistent with the 7 to 14 dwelling units per acre allowed in the MFR-14 Zone. Except for lot coverage, the project complies with all the development standards of the MFR 14 Zone. The application of the PDO Zone will allow the project to deviate from this standard, and in exchange, the proposed planned development proposes the following: 1) A well-designed, superior environment with safe pedestrian connections to recreational amenities and public right of way that otherwise could not be achieved by strict application of a conventional zone; 2) Adequate circulation system to carry the anticipated traffic volume; 3) A density/ intensity of development harmonious with surrounding development; and 4) Four sided architecture featuring elements characteristic of Spanish and Italianate style.

In summary, the requested zone change from R-6000 to MFR-14-PDO will facilitate a project that is compatible with the surrounding neighborhood.

Consistency with Title 18 – Subdivisions

The proposed Tentative Tract Map for condominium purposes complies with the development standards of the Subdivision Code (Title 18).

Consistency with the March Air Reserve Base/Inland Port Airport Land Use Compatibility Plan

CONSISTENCY TABLE

The project site is located within Zone D (Flight Corridor Buffer) of the March Air Reserve Base Airport Land Use Compatibility Plan, which has no density limitations for residential development. The proposed project was considered by the Airport Land Use Commission (ALUC) on December 12, 2024, for consistency with the D Zone and was determined to be consistent with the MARB/IPA ALUCP.

COMPLIANCE WITH APPLICABLE DEVELOPMENT STANDARDS

The table below summarizes compliance with the development standards of the proposed MFR-14 Zone and Parking Standards, subject to the approval of the Planned Development Overlay Zone standards found in Chapter 19.59 of the Perris Municipal Code.

Development Standards				
MFR-14 Multi-Family Residential and Planned Development Overlay (PDO) Zone*				
Standard		Proposed	Consistent	
Density	7-14 du/ac	13.7 du/ac	Yes	
Lot Coverage	40 percent	51 percent*	Yes, with PDO*	
Lot Minimum	3,000 sq. ft.	10.29 acres	Yes	
Building Setbacks	Front (Wilson Avenue)	20 feet	20 feet	Yes
	Streetside building setback (Nuevo Road)	15 feet	84 feet	Yes
	Interior Side Building Setback	15 feet	20 feet	Yes
	Rear Yard	15 feet	20 feet	Yes
Private Yard	200 square feet	250 square feet	Yes	
Common Open Space	150 sq. ft. Open Space per Unit 21,150 square feet	183,905 square feet	Yes	
Minimum Dwelling Size	Minimum of 1,000 sq. ft	1,600 sq. ft.	Yes	
Landscape Coverage	30 percent	36.3 percent	Yes	

Note: *PDO Zone allows flexibility concerning lot standards, and yard requirements as deemed appropriate by the approving authority.

Chapter 19.69 - Parking Standards				
Requirements of Section 19.69.20 (B) and Section 19.59.040 (B.2.) General Regulations				
Use	Standard – Single Family	Required	Proposed	Consistent
Visitor Parking	0.3 – 0.5 Spaces per unit (141 units)	71 spaces	77 spaces	Yes
Covered Parking	2 garage spaces/unit - 141 units	282 spaces	282 spaces	Yes
Total Parking		353 spaces	359 spaces	Yes
Total Surplus Parking		6 spaces		

COMPLIANCE APPLICABLE REQUIREMENTS

➤ **Building Elevations/Architecture**

The Project includes Spanish and Italianate architectural styles featuring tile roofs, wrought iron details, cement plastered walls, shutters, arches, knee braces, cantilevered elements, decorative coach lights, and wood corbels. The front entrances have been designed to include a small porch and garage doors with windows. The buildings include four-sided architecture enhanced by shutters, clay vents, and wrought iron fixtures. The proposed colors include earthtone colors such as Wheat Penny (brown), Smoke House (dark brown), and Omega (mocha). The project is consistent with the City's Residential Design Guidelines (RDG).

➤ **Amenities**

In accordance with the MFR-14 Zone, all multi-family developments are required to provide on-site amenities. A 120-unit or more development would require a clubhouse, court game facilities (tennis, basketball, racquetball), a swimming pool and spa, barbecue with seating area, and a tot-lot with play equipment. The project includes the following amenities: tennis/pickle ball courts, covered outdoor picnic seating areas, cornhole courts, dog park, a tot-lot play area, a community pool with spa, and a 766-square-foot pool building, consistent with the majority of the required amenities. However, the project does not include a clubhouse.

The applicant is supporting their decision not to include a clubhouse by referencing the flexibility allowed by the PDO Zone concerning development standards. These standards typically include adaptable lot requirements, yard setbacks, and open space areas, which may not be achievable under other zoning districts. In addition, the applicant indicated that a clubhouse would result in an undue development cost and maintenance burden that would be apportioned onto the future homeowners.

➤ **Landscaping**

The applicant has submitted a conceptual landscape plan conforming to Chapter 19.70 (Landscaping) of the Perris Municipal Code to create a sense of place, screen parking areas, and soften hardscape areas. The proposed on-site landscaping coverage totals approximately 183,905 square feet, equivalent to 36.3% of the site. The conceptual landscape plan includes various 36-inch, and 24-inch trees planted throughout the site for shade and to enhance the buildings, walkways, parking, common open space, amenities, main entrance, and the site's perimeter. Also, the proposed conceptual landscape plan has

been designed to provide adequate plant materials along the street frontages, parking lot areas, common open space areas, and building footprint perimeter areas. In addition to landscaped areas, each entrance and exit point will be enhanced with stamped concrete, and the primary entrance will include a raised landscape center median with an entry kiosk.

➤ **Perimeter Wall/Fencing and Gates**

The project is secured by a 6-foot-high tubular steel fence with stuccoed pilasters and automatic steel gates along Wilson Avenue, and a 6-foot-high split-faced block wall with decorative pilasters every 100 feet along Nuevo Road. A 6-foot-high vinyl fence is proposed along the southerly property line extending 482 feet from Wilson Avenue, with the remainder consisting of a 6-foot-high block wall. The fence/wall along the easterly property line consists of a 6-foot-high block wall segment extending 105 feet from Nuevo Road and a combination of retaining block wall with a 6-foot-high vinyl fence extending 822 feet, with the remainder consisting of a 6-foot-high block wall.

➤ **Homeowners Association**

As proposed by the developer and as conditioned, all project amenities, including common open spaces, the pool building, pool, dog park, internal sidewalks, and streets, on-site landscaping, fencing, internal and external walls, entry monuments and kiosk and all other project amenities will be installed by the developer and maintained in perpetuity for the life of the project by a Homeowners Association (HOA).

ENVIRONMENTAL DETERMINATION

An Initial Study was prepared for the project in accordance with the California Environmental Quality Act (CEQA), which concluded that all potential significant environmental effects could be reduced to less than significant levels with mitigation measures. In accordance with the California Environmental Quality Act (CEQA), a Notice of Intent to Adopt a Mitigated Negative Declaration (NOI) was published, with a 30-day public review period commencing on February 21, 2025, and concluding on March 24, 2025. The NOI was also posted on the City's website and at City Hall and sent to public agencies and property owners within a 300-foot radius of the Project site. During the 30-day comment period, the City received three (3) comment letters from:

1. California Department of Transportation (CADT) – The comments provided were informational in nature.
2. Riverside County Flood Control - The comments provided were informational in nature.
3. Eastern Municipal Water District (EMWD) - EMWD commented that the project proponent needs to consult with their Development Services Department to compare proposed and existing water demands and sewer flows, and prepare a Design Conditions report (DC), prior to final design and plan check.

Responses to comment letters were prepared to address the agency's comments (Exhibit H). None of the comment letters raised additional environmental concerns that have not already been addressed in the IS/MND 2403, constitute "significant new information," or meet any of the conditions in Section 15088.5 of the State CEQA Guidelines that would require recirculation of the IS/MND 2403.

PUBLIC HEARING NOTICE

A Notice of Public Hearing for the Planning Commission meeting was published in the local newspaper and sent to agencies and property owners within 300 feet of the project site. As of the writing of the staff report, staff has received no additional comments from surrounding property owners.

RECOMMENDATION

Adopt Resolution No. 25-07, recommending that the City Council adopt Mitigated Negative Declaration No. 2403 and the Mitigation Monitoring and Reporting Program and approve the Planned Development Overlay (PDO) Zone 23-05246, General Plan Amendment (GPA) 23-05247, Zone Change (ZC) 23-05245, Tentative Tract Map 23-05244 (TTM 38775), Development Plan Review (DPR) 23-00019 based on the findings contained in the Resolution and subject to the Conditions of Approval.

BUDGET (or FISCAL) IMPACT: There is no fiscal impact associated with this project since the applicant bears all project costs.

Prepared by: Nathan Perez, Senior Planner
Reviewed by: Patricia Brenes, Planning Manager

EXHIBITS:

- A. Resolution 25-07 recommending adoption of the Mitigated Negative Declaration No. 2403 and the Mitigation Monitoring and Reporting Program and approval of the project with Conditions of Approval (Planning and Fire, Engineering, Public Works, Community Services, and Building & Safety)
- B. Location/Aerial Map
- C. Existing and Proposed General Plan Map
- D. Existing and Proposed Zoning Map (PDO Zone)
- E. MARB/IPA/LUCP Map
- F. Project Plans (Site Plan, Building Elevations, Renderings, Floor Plans, Landscape Plans, and Wall/Fence Plans)
Due to the size of the files, Project Plans (Site Plan, Building Elevations, Renderings, Floor Plans, Landscape Plans, Wall and Fence Plans, Color and Material Sample Sheet, etc.) are available online at:
https://www.cityofperris.org/departments/development-services/planning/environmental-documents-for-public-review/-folder-517#docan1206_1313_479
- G. Tentative Tract Map No. 38775
- H. Initial Study/Mitigated Negative Declaration and Associated Technical Studies.
Due to the size of the file, the documents are available online at:
https://www.cityofperris.org/departments/development-services/planning/environmental-documents-for-public-review/-folder-527#docan1206_1313_479
- I. Applicant's Recreational Amenity Response Letter
- J. Notice of Public Hearing

Exhibit I

**Applicant Prepared Outreach Letter (dated
July 10, 2025)**



July 10, 2025

Dear Resident,

D.R. Horton is planning a new subdivision (Tentative Tract Map 38775) at Wilson Ave. and Nuevo Rd. in the City of Perris. This gated community will include 141 townhomes, along with a pool and recreation facilities. We recognize that you may have questions or concerns about this project.

To address any inquiries, we are hosting an informational meeting at the Perris High School Student Union Room (175 E. Nuevo Road) on Wednesday, July 23, 2025, at 5:00 p.m. If you would like to attend, please email me at rwoosley@drhorton.com or call (951) 739-5441 with your name, phone number, and address.

We look forward to meeting you and discussing our development plans.

Sincerely,

A handwritten signature in blue ink, appearing to read "RW" followed by a long horizontal flourish.

Ryan Woosley
Director of Forward Planning



Exhibit J

Initial Study/Mitigated Negative Declaration
and Associated Technical Studies.

*Due to the size of the file, the documents
are available online at:*

[https://www.cityofperris.org/departments/
development-
services/planning/environmental-
documents-for-public-review/-folder-
517#docan1206_1313_479](https://www.cityofperris.org/departments/development-services/planning/environmental-documents-for-public-review/-folder-517#docan1206_1313_479)

Exhibit K

Notice of Public Hearing



NOTICE OF PUBLIC HEARING

This may affect your property. Please read:

Notice is hereby given that the Planning Commission of the City of Perris will hold a Public Hearing on the following item(s):

CASES: General Plan Amendment (GPA) 23-05247,
Zone Change (ZC) 23-05245,
Planned Development Overlay (PDO) 23-05246,
Tentative Tract Map 23-05244 (TTM 38775),
Development Plan Review (DPR) 23-00019

APPLICANT: Ryan Woosley, D.R. Horton

LOCATION: Generally located at the southeast corner of Nuevo Road and Wilson Avenue

PROPOSAL: To consider the following entitlements to facilitate the construction of 141 townhome-style condominiums and amenities including a central area with pickleball courts, a tot lot, a pool and pool house, and open space: 1) General Plan Amendment and Zone Change to change the land use designation of 11.6 acres from R-6,000 to Multi-Family Residential-14 Planned Development Overlay (MFR-14-PDO) to allow a higher residential density; 2) Planned Development Overlay to allow flexibility from the development standards; 3) Tentative Tract Map for one condominium lot with two (2) lettered lots; and 4) Development Plan Review for review of the site plan and building elevations.

ENVIRONMENTAL DETERMINATION:

Recommend the adoption of the Mitigated Negative Declaration (MND 2403), as the project will not have a significant effect on the environment. MND 2403 is available for public review at the City of Perris Planning Division, 135 North "D" Street, Perris, California 92570-2200. The Planning Counter is open Monday – Friday 8:00 a.m. – 5:00 p.m. *Electronic copies can be viewed on the City's website at:*

https://www.cityofperris.org/departments/development-services/planning/environmental-documents-for-public-review/-folder-477#docan1206_1313_479

The MND/Initial Study was circulated for a 30-day review period from February 21, 2025, to March 24, 2025.

Any person affected or concerned by this application may submit written comments to the Office of the City Clerk before 5:00 p.m. on the day of the Planning Commission hearing. At the public hearing, any person may appear and be heard in support of or opposition to the project. The Planning Commission, at the hearing or during deliberations, could recommend approval of an alternative proposal for the above project, including any changes to the proposal.

Any person challenging this project in court may be limited to raising only those issues identified at the public hearing described in this notice or in writing delivered to the Planning Commission prior to the public hearing.



CITY OF PERRIS PLANNING COMMISSION PUBLIC HEARING

COUNCIL CHAMBERS CITY HALL
101 NORTH "D" STREET
PERRIS, CA 92570

Date & Time: **August 20, 2025** – 6:00 p.m.
Contact Planner: Nathan Perez, Senior Planner
nperez@cityofperris.org
(951) 943-5003, ext. 279

Si necesita un intérprete por favor llámenos al (951) 943-5003
All information is available for review at the Development Services Department, Planning Division, located at 135 North D Street, Perris.