

Owner
Optimus Building Corp.
629 Dufranc Ave.
Sebastopol, CA 95472

Architect
SMS Architects
26940 Aliso Viejo Parkway, Suite 120
Aliso Viejo, CA 92656

Parcel 1	Parcel 2	Parcel 3
C-STORE (retail) 5,637 sf	Building 1.2 (fast food) 3,000 sf	Building 1.1 (fast food) 3,340 sf
Total 5,637 sf	Total 3,000 sf	Total 3,340 sf
Parking Required 23 spaces	Parking Required 30 spaces	Parking Required 38 spaces
Parking Provided 33 spaces	Parking Provided 36 spaces	Parking Provided 40 spaces

Parcel A	Parcel B	Parcel C/D
2.49 AC	2.15 AC	4.36 AC
Building 1 (fast food) 3,400 sf	Building 3 (restaurant) 6,000 sf	Pad 5 (car wash) 5,425 sf
Building 2 (restaurant) 6,000 sf	Building 4 (fast food) 3,000 sf	Pad 6 (fast food) 3,000 sf
Total 9,400 sf	Total 9,000 sf	Pad 7 (fast food) 2,200 sf
Parking Required 62 spaces	Parking Required 58 spaces	Pad 8 (c-store/gas station) 4,088 sf
Parking Provided 128 spaces	Parking Provided 117 spaces	Total 14,713 sf
		Parking Required 81 spaces
		Parking Provided 100 spaces

Typical Parking Detail

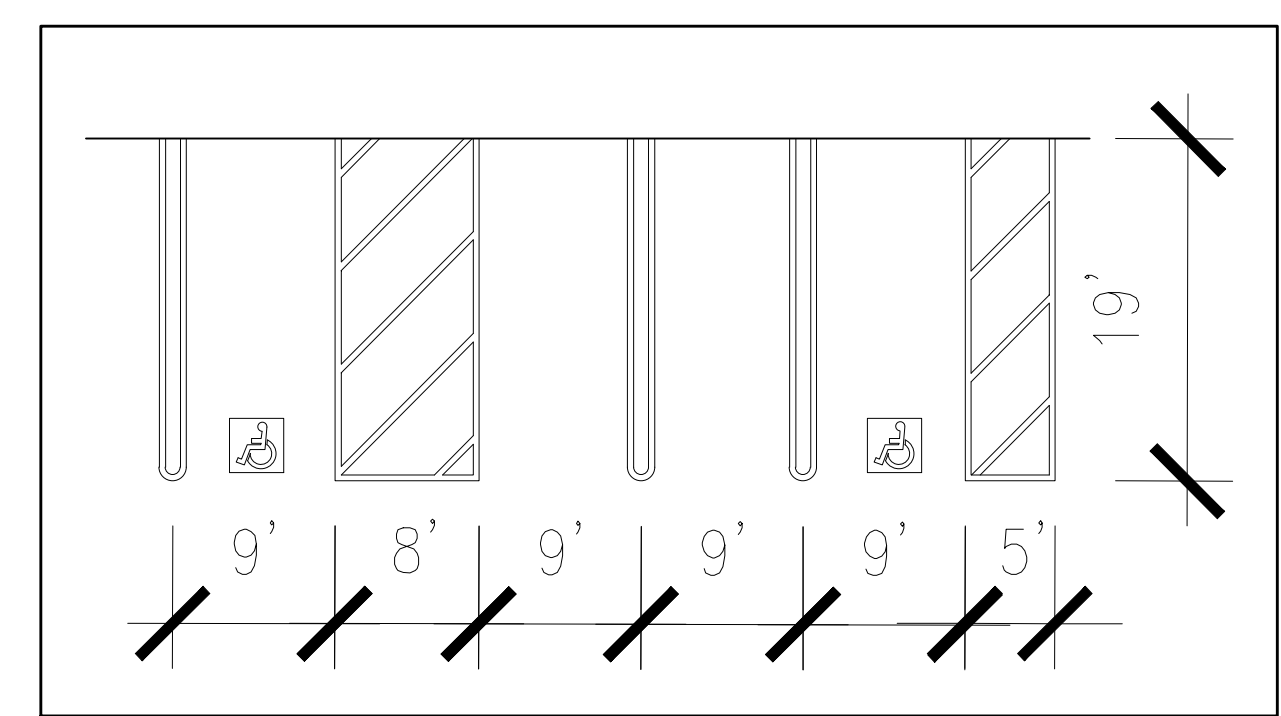

Vicinity Map

