

**City of Perris**  
**Department of Development Service**  
**Office of the Fire Marshal**  
**135 North “D” Street, Perris CA. 92570**  
**Phone: (951) 443-1029 Fax: (951) 943-3293**

## **Spray Booth Guideline**

### **PURPOSE**

The intent of this guideline is to provide the information necessary to ensure that the design and installation of spray booths will comply with the applicable provisions of the 2022 California Fire Code (CFC), 2022 California Building Code (CBC), 2022 California Electrical Code (CEC), 2022 California Mechanical Code (CMC), as adopted by the State of California, and locally adopted ordinances enforced by the City of Perris Office of the Fire Marshal (OFM).

### **SCOPE**

A spray booth is a mechanically ventilated appliance provided to enclose or accommodate a spraying operation, to confine and limit the escape of spray, vapor and residue, and exhausting it safely. Spray booths are manufactured or constructed in a variety of forms to control the unique hazards associated with flammable sprays and vapors.

This guideline is applicable to any spray booth in which spraying operations utilizing flammable or combustible liquids and combustible powders are conducted per the CFC.

### **SUBMITTAL REQUIREMENTS**

#### **1. Review and Inspection Process**

All new plan submittals and revisions will consist of 3 plan hard copies. Plans and the appropriate equipment data sheets for the spray booth(s) shall be reviewed and approved by OFM prior to installation. These plans shall be drawn with all dimensions identified or drawn to scale, and they must demonstrate compliance with the CFC, CBC, and the provisions in this guideline.

An approved Chemical Classification Packet shall be required prior to plan approval of any equipment utilizing flammable and/or combustible liquids. The storage, use, and handling of flammable and combustible liquids shall be in

accordance with CFC Chapter 57. A chemical inventory shall be provided for OFM review. Follow the requirements contained in the OFM "Chemical Classification Packet" guideline. CFC 2403.3, 5001.5.2

Plans for the extinguishing system required in the booth rooms shall be submitted by a licensed fire protection contractor (C-16 license) responsible for the work. Spray Booth plans shall be approved prior submittal of the extinguishing system. CFC 2404.4

Following the plan review process, contact the OFM Inspection Scheduling office at (951) 956-2117 to request an inspection to verify compliance with the approved plans, codes, and standards and to witness testing of any chemical-based fire extinguishing system.

## **2. Permits**

A permit is required for spraying or dipping operations utilizing flammable or combustible liquids or the application of combustible powders regulated by the CFC. Prior to issuance of this permit, plans that detail compliance with the applicable codes must be submitted to the city building department for review and approval. A permit to operate is issued after the booth and extinguishing system have been installed, inspected, and approved. CFC 2401.3

## **3. Submittal Requirements**

### **A. General Requirements**

- 1) Spray booths shall be substantially constructed of steel not less than 0.0478 inches (18 gauge) in thickness or other approved noncombustible material. CFC 2404.3.3.1
- 2) The aggregate area of spray booths in a building shall not exceed the lesser of 10% of the area of any floor of the building or the basic area allowed for a Group H, Division 2 occupancy, without area increases, as set forth in CFC 2404.3.3.6.
- 3) The area of any individual spray booth in a building shall not exceed the lesser of the aggregate size limit or 500 square feet when only a single booth is proposed. CFC 2404.3.3.6
- 4) Spray booths shall be separated from other operations by not less than three feet, by a wall or partition, or by a greater distance as required by the Fire Marshal when specific conditions are defined. CFC 2404.3.3.5.

- 5) All portions of spray booths shall be readily available for cleaning, and a clear space of not less than three feet around the booth shall be kept free of storage or combustible materials. The space required for cleaning would no longer be required if the space adjacent to the wall or partition is sealed. CFC 2404.3.3.5.
- a) Exit doors from pre-manufactured paint spray booths shall not be less than two feet six inches wide by six feet eight inches tall. CFC 2404.3.3.4.
  - b) Areas Subject to Overspray Deposits – Electrical equipment in spraying areas that is located such that deposits of combustible residues could readily accumulate shall be specifically approved for locations containing deposits of readily ignitable residue and explosive vapors in accordance with the California Electrical Code. CFC 2403.2.1.4.
  - c) Areas Not Subject to Overspray Deposits – Electrical wiring and equipment not subject to deposits of combustible residues but located in a spraying area shall be of an explosion-proof type approved for use in a Class I, Division 1 hazardous located in accordance with the California Electrical Code (CEC). CFC 2403.2.1.2 and CEC
  - d) Electrical wiring, motors, and other equipment located outside of but within 20 feet of a spraying area and not separated from the spraying area by partitions shall not produce sparks under normal operating conditions. Such areas shall be considered a Class I, Division 2 hazardous in accordance with the CEC. CFC 2403.2.1 CEC Chapter 6 has been revised to recognize the Zone 21 and Zone 22 hazardous (classified) area classifications for combustible dusts. This correlates with NFPA 70®, National Electrical Code®, with respect to the latter's recognition of Zones 21 and 22 for electrical systems.
    - i) Class I or Class II, Division 1 Locations
    - ii) All interior locations of spray booths and rooms except as specifically provided in Section 516-3(c) of the CEC for portable equipment.
    - iii) All interior portions of exhaust ducts.
    - iv) All areas in the direct path of spray operations.
    - v) Class I or Class II, Division 2 Locations
      - (1) All space outside of, but within 20 feet horizontally and 10 feet vertically of, the Class I, Division 1 location for open spraying, and separated by partitions.

- (2) Locations outside of spraying operations conducted within a closed-top, open-face, or open-front booth or room extending from the edge of the open-face or open-front of the booth or room as follows (Figure 1).
  - (a) Locations measuring 5 feet horizontally and 3 feet vertically when the exhaust ventilation system is interlocked with the spray application equipment.
  - (b) Locations measuring 10 feet horizontally and 3 feet vertically when the exhaust ventilation system is not interlocked with the spray application equipment.
  - (c) Locations measuring 3 feet vertically above the booth and within 3 feet of other booth openings when spraying operations are conducted within an open-top spraying booth (Figure 2).
- vi) Zone 20. As defined in 506.5(B)(1) of NFPA 70, National Electrical Code, a Zone 20 location shall be any location where one of the following conditions exists:
  - (a) An ignitable concentration of combustible dust is present continuously.
  - (b) An ignitable concentration of combustible dust is present for long periods of time.
- vii) Zone 21. As defined in 506.5(B)(2) of NFPA 70, National Electrical Code, a Zone 21 location shall be any location where one of the following conditions exists:
  - (a) An ignitable concentration of combustible dust is likely to exist occasionally under normal operating conditions.
  - (b) An ignitable concentration of combustible dust might exist frequently because of repair or maintenance operations or because of leakage.
  - (c) Equipment is operated or processes are carried on of such a nature that equipment breakdown or faulty operations could result in the release of an ignitable concentration of combustible dust and also cause simultaneous failure of electrical equipment in a mode to cause the electrical equipment to become a source of ignition.
  - (d) An ignitable concentration of combustible dust could be communicated from an adjacent Zone 20 location, unless

communication is prevented by adequate positive pressure ventilation from a source of clean air and effective safeguards against ventilation failure are provided.

viii) Zone 22. As defined in 506.5(B)(3) of NFPA 70, National Electrical Code, a Zone 22 location shall be any location where one of the following conditions exists:

- (a) An ignitable concentration of combustible dust is not likely to occur in normal operation, and if it does occur, will only persist for a short period.
- (b) A combustible dust is handled, processed, or used, but the dust is normally confined within closed containers or closed systems from which it can escape only as a result of the abnormal operation of the equipment with which the dust is handled, processed, or used.
- (c) An ignitable concentration of combustible dust could be communicated from an adjacent Zone 21 location, unless communication is prevented by adequate positive pressure ventilation from a source of clean air and effective safeguards against ventilation failure are provided.

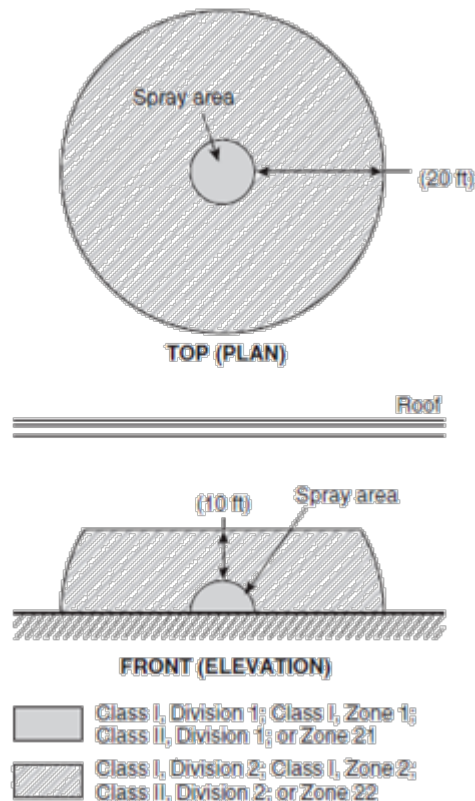

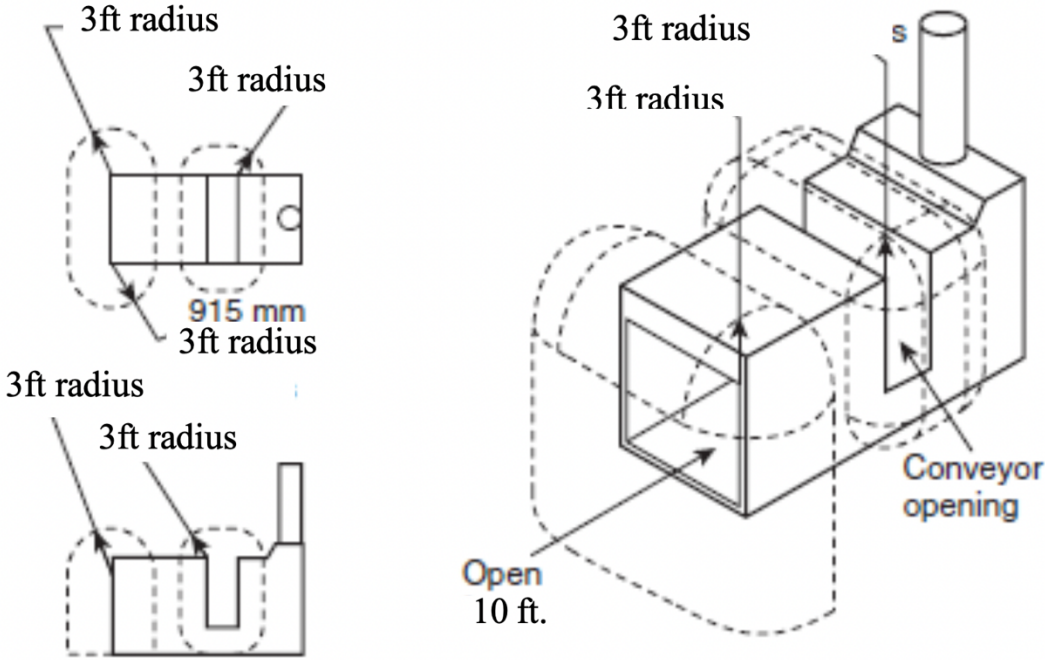

Figure 2  
Class I, Division 2/ Class I, Zone 2; Class II, Division 2; or Zone 22 Locations  
Adjacent to an Open-Face or Open-Front Spray Booth or Spray Room

Figure 1  
Electrical Area Classification for Unenclosed Spray Areas

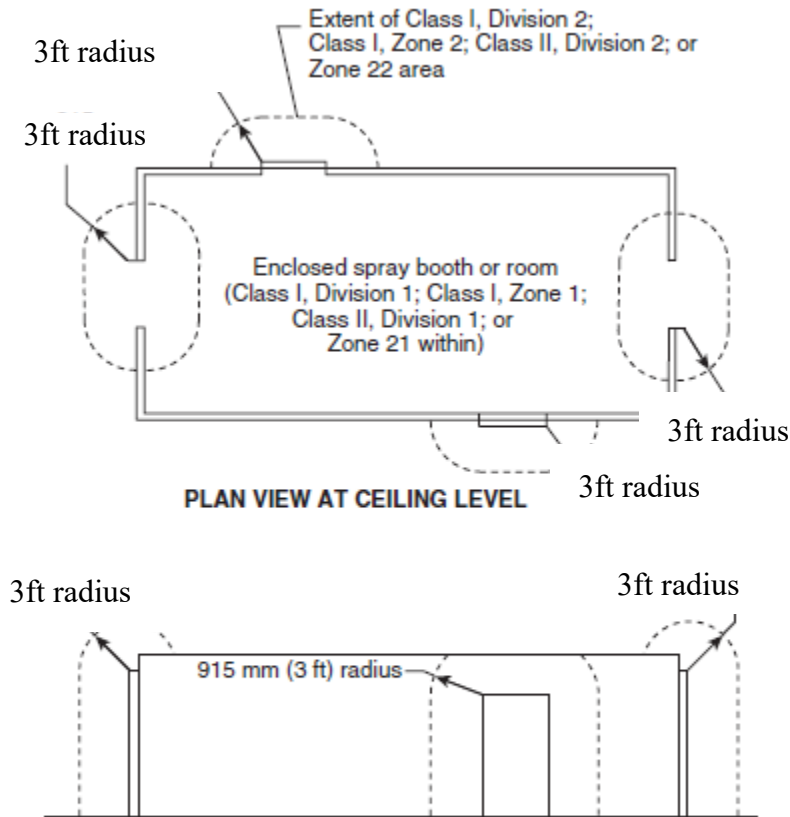

Figure 3  
 Class I, Division 2 Class I, Zone 2; Class II, Division 2; or Zone 22 Locations  
 Adjacent to an Enclosed Spray Booth or Spray Room

e) Ventilation

- i) Each spray booth shall have an independent exhaust system discharging to the building exterior. CFC 2404.7.5.
- ii) Electric motors driving exhaust fans shall not be placed inside booths or ducts. Fan rotating elements shall be nonferrous or non-sparking or casings shall consist of or be lined with such material. Belts shall not enter ducts or booths unless belts and pulleys within a duct or booth are tightly enclosed. CFC 2404.7.7.
- iii) Exhaust ducts shall be constructed of steel having a thickness in accordance with California Mechanical Code (CMC) Tables 506.2(1), 506.2(2).

- iv) The termination point for exhaust ducts shall not be less than the distances stated in CFC 2404.7.6 and the following table.
- v) Exhaust ducts shall have a clearance from combustible construction or material of not less than 18 inches unless equipped with fire protection system and operating below 140 degrees F, the clearance can then be reduced to 6". CMC 506.10 - 506.10.4
- vi) Other methods of duct clearance reduction are allowed per CMC 506.11 and Table 506.11
- vii) Clean-out openings shall be provided at intervals that allow thorough cleaning of ducts. Clean-out openings shall have tight-fitting sliding or hinged doors with metal equal to or greater than the thickness of the duct or pipe and the doors shall latch tightly. CMC 510.3.

<i>Duct Type:</i>	<b>Distance:</b>				
	<b>from property line</b>	<b>from openings into the building</b>	<b>from exterior walls or roofs</b>	<b>from combustible walls or openings into the building which are in the direction of the exhaust discharge</b>	<b>above adjoining grade</b>
<b>Ducts conveying explosive or flammable vapors, fumes, or dust</b>	30'	10'	6'	30'	10'

**B. Drying Apparatus**

- 1) The spraying apparatus, drying equipment, and ventilating system for the spray booth or spraying room shall be equipped with suitable interlocks which shall (CFC 2404.6.1.2.1):
  - a. Prevent the operation of spraying apparatus while drying operations are in progress.
  - b. Purge spray vapors from the spray booth or spraying room for a period of not less than three minutes before drying apparatus can be operated.

- c. Have the ventilating system maintain a safe atmosphere within the spray booth or spraying room during the drying process and automatically shut off drying apparatus in the event of a failure of the ventilating system.
- d. Automatically shut off the drying apparatus if the air temperature within the booth exceeds 200°F, when other than portable infrared drying apparatus is used.

#### **4. Fire Protection Equipment**

- 1) Spray booths, spraying rooms shall be protected by approved automatic fire extinguishing systems. These systems shall be extended to protect exhaust plenums, exhaust ducts, and both sides of dry filters when such filters are used, any solvent concentrator units, and recirculation air supply units. CFC 2404.4
- 2) If a building's sprinkler system is monitored for waterflow by a central monitoring station and the same fire sprinkler system is used to protect the spray booth, then the valve for the sprinkler system required for the spray booth shall have a tamper switch. CFC 903.4
- 3) Portable Fire extinguishers shall be provided with fire extinguishers in accordance with CFC 906.1. This may be accomplished by placing a 40BC fire extinguisher within 30' of the spray-booth at an approved location.

#### **C. Required Notes**

- 1) Copy the OFM required notes, verbatim, on the plans (see next page).

## CITY OF PERRIS NOTES

Place all of the following notes, verbatim, on the plans:

### City of Perris Spray Booth Notes

1. Office of the Fire Marshal (OFM) final inspection required. Please schedule all field inspections at least 48 hours in advance. Call OFM Inspection Scheduling at 951 956-2117. For permits issued in ACCELA go to <HTTPS://ACA.ACCELA.COM/PERRIS/> to sign up for Inspection Requests.
2. Smoking shall be prohibited in spray finishing areas, mixing rooms, and in the vicinity of dip tanks. **“NO SMOKING”** signs shall be conspicuously posted in such areas. CFC 2403.2.6.
3. Welding warning signs shall be posted in the vicinity of spraying areas, dipping operations, and paint storage rooms with the following warning: **“NO WELDING — The use of welding and/or cutting equipment in or near this area is dangerous because of fire and explosion hazards. Welding and cutting shall be done only under the supervision of the person in charge.”** CFC 2403.2.7.
4. Electrical wiring and equipment shall be in accordance with CFC 24, NFPA 70, and the California Electrical Code. CFC 2403.2.1.
5. Interior surfaces of spray booths shall be smooth and continuous without edges and otherwise designed to prevent pocketing of residue, to allow free passage of exhaust air from all pockets of the interior, and to facilitate washing and cleaning without injury. CFC 2404.3.3.2.
6. Floors shall be of noncombustible material or shall be covered with a noncombustible, non-sparking material of such character to facilitate safe cleaning and removal of residue. CFC 2404.3.2.
7. When spray booths are illuminated, fixed lighting units that transmit light into the spray booth through heat-treated or hammered wire glass shall be used. Glass panels shall be arranged to minimize breakage and so that normal accumulation of residue on the exposed surface of a panel will not be raised to 200°F by the heat from the source of the illumination. CFC 2404.6.2.
8. Portable electric lamps shall not be used in spraying areas during a spraying operation. CFC 2404.6.2.4.

9. Metal parts of spray booths, exhaust ducts, and piping systems conveying Class I or Class II liquids shall be electrically grounded in accordance with the National Electrical Code. CFC 2403.2.5.
10. Spraying areas shall be provided with mechanical ventilation adequate to prevent the dangerous accumulation of vapors. CFC 2404.7.
11. Mechanical ventilation shall be kept in operation at all times while spraying operations are being conducted and for a sufficient time thereafter to allow vapors from drying coated articles and finishing material residue to be exhausted. CFC 2404.7.1.
12. Spraying equipment shall be interlocked with the ventilation of the spraying area such that spraying operations cannot be conducted unless the ventilation system is in operation. CFC 2404.8.
13. Recirculation ventilation systems shall have approved vapor detection systems. If the approved vapor concentration in the re-circulated air stream exceeds 25 percent of the lower flammability limit, the system shall automatically shut down the spraying operation, switch the ventilation system to 100 percent outdoor exhaust and sound an alarm. CFC 2404.7.2.
14. Ventilation systems shall be designed, installed and maintained such that the average air velocity over the open face of the booth, or booth cross-section, in the direction of airflow during spraying operations shall not be less than 100 lineal feet per minute. CFC 2404.7.3.
15. Portable fire extinguishers shall be provided for spraying areas in accordance with the requirements for an extra (high) hazard occupancy (e.g., 4-A:40-BC within 30 feet of the booth). CFC 2404.4.1 and 906.
16. Spray booths and spraying rooms shall not be alternately used for the purpose of drying arrangements which would cause a material to increase the surface temperature of the spray booth or room unless used for automobile refinishing in accordance with Section CFC 2404.6.1 and 2404.6.1.2.2
17. Housekeeping, maintenance and storage of hazardous materials. Housekeeping, maintenance, storage and use of hazardous materials shall be in accordance with Sections 2403.3, 2403.4, 2404.5.1 and 2404.5.2.
18. Waste cans: Approved metal waste cans equipped with self-closing lids shall be provided whenever rags or waste are impregnated with finishing materials. Such rags and waste shall be deposited therein immediately after being utilized. The content of waste cans shall be properly deposited of at least once daily and at the end of each shift.