

Appendix F-1

(Site 1 – North Nance)

Project Specific Preliminary Water Quality
Management Plan, North Nance Trailer Yard,
Northwest Corner Of Webster Avenue And
Nance Street

Thienes Engineering, Inc.

July 22, 2022



Thienes Engineering, Inc.
CIVIL ENGINEERING • LAND SURVEYING

**PROJECT SPECIFIC PRELIMINARY
WATER QUALITY MANAGEMENT PLAN
(P-WQMP)**

FOR:

PXX-XXXXX

NORTH NANCE TRAILER YARD

NORTHWEST CORNER OF WEBSTER AVENUE AND NANCE STREET
PERRIS, CALIFORNIA 92571

APNs: 314-153-058, -060, -062, -064, -066, -068, -070, AND -082

PREPARED FOR:

LAKE CREEK INDUSTRIAL LLC

1302 BRITTANY CROSS ROAD

SANTA ANA, CA 92705

PHONE: (949) 910-4616

CONTACT: MIKE TONKONOGY

JULY 22, 2022

JOB NO. 4108

PREPARED BY:

THIENES ENGINEERING, INC.

14349 FIRESTONE BLVD.

LA MIRADA, CALIFORNIA 90638

PHONE: (714) 521-4811

FAX: (714) 521-4173

CONTACT: LUIS PRADO (luisp@thieneseng.com)

**PROJECT SPECIFIC PRELIMINARY
WATER QUALITY MANAGEMENT PLAN
(P-WQMP)**

FOR

“NORTH NANCE TRAILER YARD”



PREPARED BY LUIS PRADO
UNDER THE SUPERVISION OF:

REINHARD STENZEL
R.C.E. 56155
EXP. 12/31/2022

7/22/22
DATE

Project Specific Water Quality Management Plan

A Template for Projects located within the **Santa Ana Watershed** Region of Riverside County

Project Title: North Nance Trailer Yard

Development No: PXX-XXXXX

Design Review/Case No: PXX-XXXXX

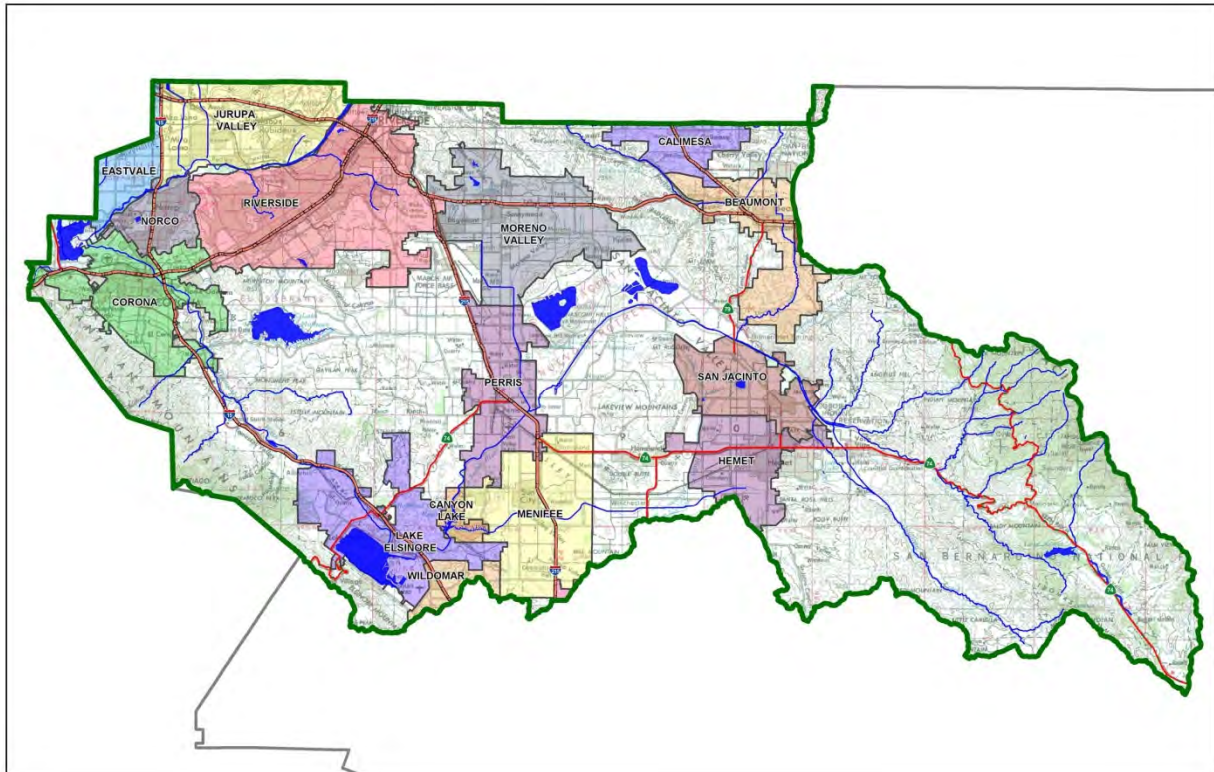

- Preliminary
- Final

Original Date Prepared: July 22, 2022

Revision Date(s):

Prepared for Compliance with

*Regional Board Order No. **R8-2010-0033***

Contact Information:

Prepared for:

Lake Creek Industrial LLC
1302 Brittany Cross Road
Santa Ana, CA 92705
Phone: (949) 910-4616
Contact: Mike Tonkonogy

Prepared by:

Thienes Engineering, Inc.
14349 Firestone Boulevard
La Mirada, CA 90638
(714) 521-4811
Contact: Luis Prado (luisp@thieneseng.com)
Job No. 4108

A Brief Introduction

This Project-Specific WQMP Template for the **Santa Ana Region** has been prepared to help guide you in documenting compliance for your project. Because this document has been designed to specifically document compliance, you will need to utilize the WQMP Guidance Document as your “how-to” manual to help guide you through this process. Both the Template and Guidance Document go hand-in-hand, and will help facilitate a well prepared Project-Specific WQMP. Below is a flowchart for the layout of this Template that will provide the steps required to document compliance.

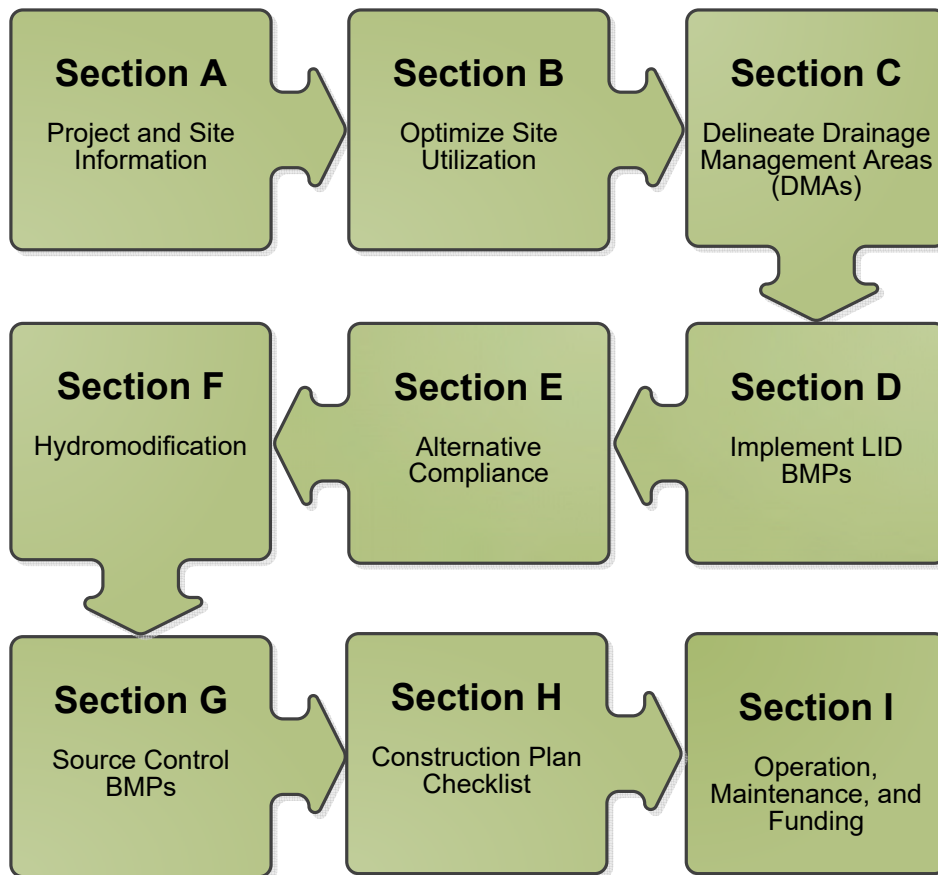

OWNER'S CERTIFICATION

This Project-Specific Water Quality Management Plan (WQMP) has been prepared for **Lake Creek Industrial LLC** by **Thienes Engineering, Inc.** for the **North Nance Trailer Yard** project (PXX-XXXXX).

This WQMP is intended to comply with the requirements of **City of Perris** for **Ordinance No. 1194** which includes the requirement for the preparation and implementation of a Project-Specific WQMP.

The undersigned, while owning the property/project described in the preceding paragraph, shall be responsible for the implementation and funding of this WQMP and will ensure that this WQMP is amended as appropriate to reflect up-to-date conditions on the site. In addition, the property owner accepts responsibility for interim operation and maintenance of Stormwater BMPs until such time as this responsibility is formally transferred to a subsequent owner. This WQMP will be reviewed with the facility operator, facility supervisors, employees, tenants, maintenance and service contractors, or any other party (or parties) having responsibility for implementing portions of this WQMP. At least one copy of this WQMP will be maintained at the project site or project office in perpetuity. The undersigned is authorized to certify and to approve implementation of this WQMP. The undersigned is aware that implementation of this WQMP is enforceable under **City of Perris Ordinance No. 1194**.

"I, the undersigned, certify under penalty of law that the provisions of this WQMP have been reviewed and accepted and that the WQMP will be transferred to future successors in interest."

Owner's Signature

Mike Tonkonogy
Owner's Printed Name

Date

Manager
Owner's Title/Position

PREPARER'S CERTIFICATION

"The selection, sizing and design of stormwater treatment and other stormwater quality and quantity control measures in this plan meet the requirements of Regional Water Quality Control Board Order No. **R8-2010-0033** and any subsequent amendments thereto."

Preparer's Signature

Reinhard Stenzel
Preparer's Printed Name

Date

Director of Engineering
Preparer's Title/Position

Preparer's Licensure:

Table of Contents

Section A: Project and Site Information.....	6
A.1 Maps and Site Plans	7
A.2 Identify Receiving Waters	7
A.3 Additional Permits/Approvals required for the Project:	8
Section B: Optimize Site Utilization (LID Principles)	9
Section C: Delineate Drainage Management Areas (DMAs).....	11
Section D: Implement LID BMPs	13
D.1 Infiltration Applicability	13
D.2 Harvest and Use Assessment.....	14
D.3 Bioretention and Biotreatment Assessment	17
D.4 Feasibility Assessment Summaries	17
D.5 LID BMP Sizing	18
Section E: Alternative Compliance (LID Waiver Program)	19
E.1 Identify Pollutants of Concern	19
E.2 Stormwater Credits	20
E.3 Sizing Criteria.....	21
E.4 Treatment Control BMP Selection	21
Section F: Hydromodification	22
F.1 Hydrologic Conditions of Concern (HCOC) Analysis.....	22
F.2 HCOC Mitigation.....	23
Section G: Source Control BMPs.....	24
Section H: Construction Plan Checklist	26
Section I: Operation, Maintenance and Funding.....	27

List of Tables

Table A.1 Identification of Receiving Waters.....	7
Table A.2 Other Applicable Permits.....	8
Table C.1 DMA Classifications.....	11
Table C.2 Type 'A', Self-Treating Areas.....	11
Table C.3 Type 'B', Self-Retaining Areas.....	11
Table C.4 Type 'C', Areas that Drain to Self-Retaining Areas.....	12
Table C.5 Type 'D', Areas Draining to BMPs.....	12
Table D.1 Infiltration Feasibility.....	13
Table D.2 LID Prioritization Summary Matrix.....	17
Table D.3 DCV Calculations for LID BMPs.....	18
Table E.1 Potential Pollutants by Land Use Type.....	20
Table E.2 Water Quality Credits.....	20
Table E.3 Treatment Control BMP Sizing.....	21
Table E.4 Treatment Control BMP Selection.....	21
Table F.1 Hydrologic Conditions of Concern Summary.....	22
Table G.1 Permanent and Operational Source Control Measures.....	24
Table H.1 Construction Plan Cross-reference.....	26

List of Appendices

Appendix 1: Maps and Site Plans.....	28
Appendix 2: Construction Plans.....	29
Appendix 3: Soils Information.....	30
Appendix 4: Historical Site Conditions.....	31
Appendix 5: LID Infeasibility.....	32
Appendix 6: BMP Design Details.....	33
Appendix 7: Hydromodification.....	34
Appendix 8: Source Control.....	35
Appendix 9: O&M.....	36
Appendix 10: Educational Materials.....	37

Section A: Project and Site Information

PROJECT INFORMATION	
Type of Project:	Light Industrial Warehouse
Planning Area:	Industrial/Business Park
Community Name:	N/A
Development Name:	North Nance Trailer Yard
PROJECT LOCATION	
Latitude & Longitude (GIS): 33.856008, -117.245053	
Project Watershed and Sub-Watershed: Santa Ana River & San Jacinto	
APN(s): 314-153-058, -060, -062, -064, -066, -068, -070, and -082	
Total Project Area: 5.18 acres	
Map Book and Page No.: Assessor's Map BK314 PG. 15	
PROJECT CHARACTERISTICS	
Proposed or Potential Land Use(s)	Light Industrial
Proposed or Potential SIC Code(s)	4225
Area of Existing Impervious Project Footprint (SF)	0
Total Area of <u>proposed</u> Impervious Surfaces within the Project Limits (SF)/or Replacement	174,240 (4.00 acres)
Does the project consist of offsite road improvements?	<input type="checkbox"/> Y <input checked="" type="checkbox"/> N
Does the project propose to construct unpaved roads?	<input type="checkbox"/> Y <input checked="" type="checkbox"/> N
Is the project part of a larger common plan of development (phased project)?	<input type="checkbox"/> Y <input checked="" type="checkbox"/> N
EXISTING SITE CHARACTERISTICS	
Total area of <u>existing</u> Impervious Surfaces within the project limits (SF)	0
Is the project located within any MSHCP Criteria Cell?	<input type="checkbox"/> Y <input checked="" type="checkbox"/> N
If so, identify the Cell number:	N/A
Are there any natural hydrologic features on the project site?	<input type="checkbox"/> Y <input checked="" type="checkbox"/> N
Is a Geotechnical Report attached?	<input checked="" type="checkbox"/> Y <input type="checkbox"/> N
If no Geotech. Report, list the NRCS soils type(s) present on the site (A, B, C and/or D)	Geotechnical Report Available
What is the Water Quality Design Storm Depth for the project?	0.62 inches

Project Description:

The project site encompasses approximately 5.18 acres. Proposed improvements include trailer parking and one office type building on the west side of the site. Vehicle parking is located on the southwesterly portion of the site. There are landscaped areas throughout.

Per the infiltration report, the geotechnical engineer concluded that infiltration is not considered feasible due to non-permeable soils that underlay the site. Based on this, the rates are assumed to be 0.0 in/hr which puts the site at biotreatment BMPs such as the extended detention basin. However, the site is located within Riverside County's Airport Land Use Commission's (ALUC) jurisdiction; specifically, within Zone B1. ALUC guidelines ("Wildlife Hazard Management at Riverside County Airports: Background and Policy" dated October 2018, Table 5-4) specifically states that extended detention basins are prohibited in Zones A through D. As a result, the project proposes to use an equivalent underground biotreatment solution with an underground detention system and proprietary biotreatment unit to treat runoff produced by the 85th percentile storm rainfall depth. Catch basin filters will be provided in order to pre-treat runoff prior to entering the water quality devices.

Existing Site:

The site is currently an undeveloped lot with sparse vegetation. The site generally sheet flows northeasterly to N. Webster Avenue. Flows are conveyed northerly in the street and discharge into an existing catch basin in N. Webster Avenue.

Hydrology:

In the proposed condition, the site will continue to generally drain northeasterly. The westerly parking lot and landscaped area drains to a catch basin located in the parking lot. A proposed onsite storm drain system will convey water easterly around the proposed building and northeasterly through the trailer parking area. The trailer parking area will drain northeasterly to catch basins located in the parking area. Flows will confluence with runoff from the west and continue easterly toward N. Webster Avenue. Flows will ultimately discharge into the existing RCB in N. Webster Avenue.

The driveway and landscaped area fronting Nance Street and the landscaped area fronting N. Webster Avenue sheet flow to each respective street. Flows will be conveyed northerly in N. Webster Avenue and discharge into the existing curb opening catch basin. The landscaped areas are considered self-treating.

A.1 Maps and Site Plans

When completing your Project-Specific WQMP, include a map of the local vicinity and existing site. In addition, include all grading, drainage, landscape/plant palette and other pertinent construction plans in Appendix 2. At a **minimum**, your WQMP Site Plan should include the following:

- Drainage Management Areas
- Proposed Structural BMPs
- Drainage Path
- Drainage Infrastructure, Inlets, Overflows
- Source Control BMPs
- Buildings, Roof Lines, Downspouts
- Impervious Surfaces
- Standard Labeling

Use your discretion on whether or not you may need to create multiple sheets or can appropriately accommodate these features on one or two sheets. Keep in mind that the Co-Permittee plan reviewer must be able to easily analyze your project utilizing this template and its associated site plans and maps.

A.2 Identify Receiving Waters

Using Table A.1 below, list in order of upstream to downstream, and the receiving waters that the project site is tributary to. Continue to fill each row with the Receiving Water's 303(d) listed impairments (if any), designated beneficial uses, and proximity, if any, to a RARE beneficial use. Include a map of the receiving waters in Appendix 1.

Table A.1 Identification of Receiving Waters

Receiving Waters	EPA Approved 303(d) List Impairments	Designated Beneficial Uses	Proximity to RARE Beneficial Use
RCB in N. Webster Avenue	None	None	Not classified as a RARE waterbody.
San Jacinto River, Reach 3	None	AGR, GWR, REC1, REC2, WARM, WILD	Not classified as a RARE waterbody.
Canyon Lake (aka San Jacinto River, Reach 2)	Nutrients	MUN, AGR, GWR, REC1, REC2, WARM, WILD	Not classified as a RARE waterbody.
San Jacinto River, Reach 1	None	MUN, AGR, GWR, REC1, REC2, WARM, WILD	Not classified as a RARE waterbody.
Lake Elsinore	DDT, Nutrients, Organic Enrichment/Low Dissolved Oxygen, PCBs, Toxicity	REC1, REC2, WARM, WILD	Not classified as a RARE waterbody.

A.3 Additional Permits/Approvals required for the Project:

Table A.2 Other Applicable Permits

Agency	Permit Required	
State Department of Fish and Game, 1602 Streambed Alteration Agreement	<input checked="" type="checkbox"/> Y	<input type="checkbox"/> N
State Water Resources Control Board, Clean Water Act (CWA) Section 401 Water Quality Cert.	<input checked="" type="checkbox"/> Y	<input type="checkbox"/> N
US Army Corps of Engineers, CWA Section 404 Permit	<input checked="" type="checkbox"/> Y	<input type="checkbox"/> N
US Fish and Wildlife, Endangered Species Act Section 7 Biological Opinion	<input checked="" type="checkbox"/> Y	<input type="checkbox"/> N
Statewide Construction General Permit Coverage	<input checked="" type="checkbox"/> Y	<input type="checkbox"/> N
Statewide Industrial General Permit Coverage (dependent on tenant)	<input checked="" type="checkbox"/> Y	<input type="checkbox"/> N
Western Riverside MSHCP Consistency Approval (e.g., JPR, DBESP)	<input type="checkbox"/> Y	<input checked="" type="checkbox"/> N
Other (please list in the space below as required)	<input checked="" type="checkbox"/> Y	<input type="checkbox"/> N
City of Perris Grading Permit	<input checked="" type="checkbox"/> Y	<input type="checkbox"/> N
Other (please list in the space below as required)	<input checked="" type="checkbox"/> Y	<input type="checkbox"/> N
City of Perris Building Permit	<input checked="" type="checkbox"/> Y	<input type="checkbox"/> N

If yes is answered to any of the questions above, the Co-Permittee may require proof of approval/coverage from those agencies as applicable including documentation of any associated requirements that may affect this Project-Specific WQMP.

Section B: Optimize Site Utilization (LID Principles)

Review of the information collected in Section 'A' will aid in identifying the principal constraints on site design and selection of LID BMPs as well as opportunities to reduce imperviousness and incorporate LID Principles into the site and landscape design. For example, **constraints** might include impermeable soils, high groundwater, groundwater pollution or contaminated soils, steep slopes, geotechnical instability, high-intensity land use, heavy pedestrian or vehicular traffic, utility locations or safety concerns. **Opportunities** might include existing natural areas, low areas, oddly configured or otherwise unbuildable parcels, easements and landscape amenities including open space and buffers (which can double as locations for bioretention BMPs), and differences in elevation (which can provide hydraulic head). Prepare a brief narrative for each of the site optimization strategies described below. This narrative will help you as you proceed with your LID design and explain your design decisions to others.

The 2010 Santa Ana MS4 Permit further requires that LID Retention BMPs (Infiltration Only or Harvest and Use) be used unless it can be shown that those BMPs are infeasible. Therefore, it is important that your narrative identify and justify if there are any constraints that would prevent the use of those categories of LID BMPs. Similarly, you should also note opportunities that exist which will be utilized during project design. Upon completion of identifying Constraints and Opportunities, include these on your WQMP Site plan in Appendix 1.

Site Optimization

The following questions are based upon Section 3.2 of the WQMP Guidance Document. Review of the WQMP Guidance Document will help you determine how best to optimize your site and subsequently identify opportunities and/or constraints, and document compliance.

Did you identify and preserve existing drainage patterns? If so, how? If not, why?

- *There are no creeks, wetlands, or riparian habitats nearby.*
- *Existing drainage patterns flow northeasterly toward N. Webster Avenue and ultimately into the RCB in N. Webster Avenue. Proposed condition drainage patterns mimic pre-development conditions.*

Did you identify and protect existing vegetation? If so, how? If not, why?

- *Not applicable, there are no sensitive areas.*
- *No applicable, there are no existing trees to preserve.*

Did you identify and preserve natural infiltration capacity? If so, how? If not, why?

- *Per the infiltration report, the geotechnical engineer concluded that infiltration is not considered feasible due to non-permeable soils; therefore, the project proposes to use an underground detention system and proprietary biotreatment unit to treat runoff produced by the 85th percentile storm rainfall depth.*

Did you identify and minimize impervious area? If so, how? If not, why?

- *Impervious area on the site has been minimized to City standards.*
- *Due to the nature of the project site (large trucks), substitution of pavement for landscaping is not feasible. The project does not propose overflow parking where substitution of pavement for*

landscaping would be optimal. Landscaping has been provided wherever applicable and to the maximum extent practicable.

- *The entire Design Capture Volume (DCV) is handled by the proposed underground detention system and proprietary biotreatment unit. Permeable pavement is not needed to meet the DCV.*

Did you identify and disperse runoff to adjacent pervious areas? If so, how? If not, why?

- *Roof runoff is directed to the underground detention system and proprietary biotreatment unit for treatment.*
- *The site is not on a hillside.*
- *All stormwater runoff will be piped or sheet flow into the underground detention system and proprietary biotreatment unit; therefore, curb-cuts into landscaped areas are not utilized.*

Section C: Delineate Drainage Management Areas (DMAs)

Utilizing the procedure in Section 3.3 of the WQMP Guidance Document which discusses the methods of delineating and mapping your project site into individual DMAs, complete Table C.1 below to appropriately categorize the types of classification (e.g., Type A, Type B, etc.) per DMA for your project site. Upon completion of this table, this information will then be used to populate and tabulate the corresponding tables for their respective DMA classifications.

Table C.1 DMA Classifications

DMA Name or ID	Surface Type(s) ¹	Area (Sq. Ft.)	Area (Acres)	DMA Type
A-1	Roofs/Conc/Asphalt	174,240	4.00	Type D
A-2	Ornamental Landscaping	15,682	0.36	Type D
B-2	Ornamental Landscaping	27,878	0.64	Type A
C-2	Ornamental Landscaping	7,841	0.18	Type A

¹Reference Table 2-1 in the WQMP Guidance Document to populate this column.

DMA B-2 and C-2 consists of landscape areas that drain offsite.

Table C.2 Type 'A', Self-Treating Areas

DMA Name or ID	Area (Sq. Ft.)	Stabilization Type	Irrigation Type (if any)
B-2	27,878	California Native Vegetation	Timed Sprinklers
C-2	7,841	California Native Vegetation	Timed Sprinklers

Table C.3 Type 'B', Self-Retaining Areas

Self-Retaining Area				Type 'C' DMAs that are draining to the Self-Retaining Area		
DMA Name/ ID	Post-project surface type	Area (square feet) [A]	Storm Depth (inches) [B]	DMA Name / ID	[C] from Table C.4 [C]	Required Retention Depth (inches) [D]
n/a	n/a	n/a	n/a	n/a	n/a	n/a

$$[D] = [B] + \frac{[B] \cdot [C]}{[A]}$$

Table C.4 Type 'C', Areas that Drain to Self-Retaining Areas

DMA					Receiving Self-Retaining DMA		
DMA Name/ ID	Area (square feet)	Post-project surface type	Runoff factor	Product	DMA name /ID	Area (square feet)	Ratio
	[A]		[B]	[C] = [A] x [B]		[D]	[C]/[D]
n/a	n/a	n/a	n/a	n/a	n/a	n/a	n/a

Table C.5 Type 'D', Areas Draining to BMPs

DMA Name or ID	BMP Name or ID
A-1	StormTech MC-3500 Chambers & Modular Wetlands System (STC-A & MWS-A)
A-2	StormTech MC-3500 Chambers & Modular Wetlands System (STC-A & MWS-A)

Note: More than one drainage management area can drain to a single LID BMP, however, one drainage management area may not drain to more than one BMP.

Section D: Implement LID BMPs

D.1 Infiltration Applicability

Is there an approved downstream ‘Highest and Best Use’ for stormwater runoff (see discussion in Chapter 2.4.4 of the WQMP Guidance Document for further details)? Y N

If yes has been checked, Infiltration BMPs shall not be used for the site. If no, continue working through this section to implement your LID BMPs. It is recommended that you contact your Co-Permittee to verify whether or not your project discharges to an approved downstream ‘Highest and Best Use’ feature.

Geotechnical Report

A Geotechnical Report or Phase I Environmental Site Assessment may be required by the Copermitttee to confirm present and past site characteristics that may affect the use of Infiltration BMPs. In addition, the Co-Permittee, at their discretion, may not require a geotechnical report for small projects as described in Chapter 2 of the WQMP Guidance Document. If a geotechnical report has been prepared, include it in Appendix 3. In addition, if a Phase I Environmental Site Assessment has been prepared, include it in Appendix 4.

Is this project classified as a small project consistent with the requirements of Chapter 2 of the WQMP Guidance Document? Y N

Infiltration Feasibility

Table D.1 below is meant to provide a simple means of assessing which DMAs on your site support Infiltration BMPs and is discussed in the WQMP Guidance Document in Chapter 2.4.5. Check the appropriate box for each question and then list affected DMAs as applicable. If additional space is needed, add a row below the corresponding answer.

Table D.1 Infiltration Feasibility

Does the project site...	YES	NO
...have any DMAs with a seasonal high groundwater mark shallower than 10 feet? If Yes, list affected DMAs:		X
...have any DMAs located within 100 feet of a water supply well? If Yes, list affected DMAs:		X
...have any areas identified by the geotechnical report as posing a public safety risk where infiltration of stormwater could have a negative impact? If Yes, list affected DMAs:		X
...have measured in-situ infiltration rates of less than 1.6 inches / hour? If Yes, list affected DMAs: Per the infiltration report, the geotechnical engineer concluded that infiltration is not considered feasible due to non-permeable soils; therefore, the project proposes to use an underground detention system and proprietary biotreatment unit to treat runoff produced by the 85th percentile storm rainfall depth for the entire site.	X	
...have significant cut and/or fill conditions that would preclude in-situ testing of infiltration rates at the final infiltration surface? If Yes, list affected DMAs:		X
...geotechnical report identify other site-specific factors that would preclude effective and safe infiltration? Describe here:		X

If you answered “Yes” to any of the questions above for any DMA, Infiltration BMPs should not be used for those DMAs and you should proceed to the assessment for Harvest and Use below.

D.2 Harvest and Use Assessment

Please check what applies:

- Reclaimed water will be used for the non-potable water demands for the project.
- Downstream water rights may be impacted by Harvest and Use as approved by the Regional Board (verify with the Copermittee).
- The Design Capture Volume will be addressed using Infiltration Only BMPs. In such a case, Harvest and Use BMPs are still encouraged, but it would not be required if the Design Capture Volume will be infiltrated or evapotranspired.
- None of the above

If any of the above boxes have been checked, Harvest and Use BMPs need not be assessed for the site. If neither of the above criteria applies, follow the steps below to assess the feasibility of irrigation use, toilet use and other non-potable uses (e.g., industrial use).

Irrigation Use Feasibility

Complete the following steps to determine the feasibility of harvesting stormwater runoff for Irrigation Use BMPs on your site:

Step 1: Identify the total area of irrigated landscape on the site, and the type of landscaping used.

Total Area of Irrigated Landscape: 1.18 acres

Type of Landscaping (Conservation Design or Active Turf): Conservative Design

Step 2: Identify the planned total of all impervious areas on the proposed project from which runoff might be feasibly captured and stored for irrigation use. Depending on the configuration of buildings and other impervious areas on the site, you may consider the site as a whole, or parts of the site, to evaluate reasonable scenarios for capturing and storing runoff and directing the stored runoff to the potential use(s) identified in Step 1 above.

Total Area of Impervious Surfaces: 4.00 acres

Step 3: Cross reference the Design Storm depth for the project site (see Exhibit A of the WQMP Guidance Document) with the left column of Table 2-3 in Chapter 2 to determine the minimum area of Effective Irrigated Area per Tributary Impervious Area (EIATIA).

Enter your EIATIA factor: 1.05

Step 4: Multiply the unit value obtained from Step 3 by the total of impervious areas from Step 2 to develop the minimum irrigated area that would be required.

Minimum required irrigated area: 4.20 acres

Step 5: Determine if harvesting stormwater runoff for irrigation use is feasible for the project by comparing the total area of irrigated landscape (Step 1) to the minimum required irrigated area (Step 4).

Minimum required irrigated area (Step 4)	Available Irrigated Landscape (Step 1)
4.20 acres	1.18 acres

Toilet Use Feasibility

Complete the following steps to determine the feasibility of harvesting stormwater runoff for toilet flushing uses on your site:

Step 1: Identify the projected total number of daily toilet users during the wet season, and account for any periodic shut downs or other lapses in occupancy:

Projected Number of Daily Toilet Users: 152 (approximate # of parking stalls)

Project Type: Light Industrial

Step 2: Identify the planned total of all impervious areas on the proposed project from which runoff might be feasibly captured and stored for toilet use. Depending on the configuration of buildings and other impervious areas on the site, you may consider the site as a whole, or parts of the site, to evaluate reasonable scenarios for capturing and storing runoff and directing the stored runoff to the potential use(s) identified in Step 1 above.

Total Area of Impervious Surfaces: 4.00 ac

Step 3: Enter the Design Storm depth for the project site (see Exhibit A) into the left column of Table 2-2 in Chapter 2 to determine the minimum number of toilet users per tributary impervious acre (TUTIA).

Enter your TUTIA factor: 185

Step 4: Multiply the unit value obtained from Step 3 by the total of impervious areas from Step 2 to develop the minimum number of toilet users that would be required.

Minimum number of toilet users: 740

Step 5: Determine if harvesting stormwater runoff for toilet flushing use is feasible for the project by comparing the Number of Daily Toilet Users (Step 1) to the minimum required number of toilet users (Step 4).

Minimum required Toilet Users (Step 4)	Projected number of toilet users (Step 1)
740	152

Other Non-Potable Use Feasibility

Are there other non-potable uses for stormwater runoff on the site (e.g. industrial use)? See Chapter 2 of the Guidance for further information. If yes, describe below. If no, write N/A.

N/A

Step 1: Identify the projected average daily non-potable demand, in gallons per day, during the wet season and accounting for any periodic shut downs or other lapses in occupancy or operation.

Average Daily Demand: N/A

Step 2: Identify the planned total of all impervious areas on the proposed project from which runoff might be feasibly captured and stored for the identified non-potable use. Depending on the configuration of buildings and other impervious areas on the site, you may consider the site as a whole, or parts of the site, to evaluate reasonable scenarios for capturing and storing runoff and directing the stored runoff to the potential use(s) identified in Step 1 above.

Total Area of Impervious Surfaces: N/A

Step 3: Enter the Design Storm depth for the project site (see Exhibit A) into the left column of Table 2-3 in Chapter 2 to determine the minimum demand for non-potable uses per tributary impervious acre.

Enter the factor from Table 2-3: N/A

Step 4: Multiply the unit value obtained from Step 4 by the total of impervious areas from Step 3 to develop the minimum number of gallons per day of non-potable use that would be required.

Minimum required use: N/A

Step 5: Determine if harvesting stormwater runoff for other non-potable use is feasible for the project by comparing the Number of Daily Toilet Users (Step 1) to the minimum required number of toilet users (Step 4).

Minimum required non-potable use (Step 4)	Projected average daily use (Step 1)
N/A	N/A

If Irrigation, Toilet and Other Use feasibility anticipated demands are less than the applicable minimum values, Harvest and Use BMPs are not required and you should proceed to utilize LID Bioretention and Biotreatment, unless a site-specific analysis has been completed that demonstrates technical infeasibility as noted in D.3 below.

D.3 Bioretention and Biotreatment Assessment

Other LID Bioretention and Biotreatment BMPs as described in Chapter 2.4.7 of the WQMP Guidance Document are feasible on nearly all development sites with sufficient advance planning.

Select one of the following:

- LID Bioretention/Biotreatment BMPs will be used for some or all DMAs of the project as noted below in Section D.4 (note the requirements of Section 3.4.2 in the WQMP Guidance Document).
- A site-specific analysis demonstrating the technical infeasibility of all LID BMPs has been performed and is included in Appendix 5. If you plan to submit an analysis demonstrating the technical infeasibility of LID BMPs, request a pre-submittal meeting with the Copermittee to discuss this option. Proceed to Section E to document your alternative compliance measures.

D.4 Feasibility Assessment Summaries

From the Infiltration, Harvest and Use, Bioretention and Biotreatment Sections above, complete Table D.2 below to summarize which LID BMPs are technically feasible, and which are not, based upon the established hierarchy.

Table D.2 LID Prioritization Summary Matrix

DMA Name/ID	LID BMP Hierarchy				Alternative Compliance (Modular Wetlands System)
	1. Infiltration	2. Harvest and use	3. Bioretention	4. Biotreatment	
A-1	<input type="checkbox"/>	<input type="checkbox"/>	<input type="checkbox"/>	<input type="checkbox"/>	<input checked="" type="checkbox"/>
A-2	<input type="checkbox"/>	<input type="checkbox"/>	<input type="checkbox"/>	<input type="checkbox"/>	<input checked="" type="checkbox"/>

For those DMAs where LID BMPs are not feasible, provide a brief narrative below summarizing why they are not feasible, include your technical infeasibility criteria in Appendix 5, and proceed to Section E below to document Alternative Compliance measures for those DMAs. Recall that each proposed DMA must pass through the LID BMP hierarchy before alternative compliance measures may be considered.

D.5 LID BMP Sizing

Each LID BMP must be designed to ensure that the Design Capture Volume will be addressed by the selected BMPs. First, calculate the Design Capture Volume for each LID BMP using the V_{BMP} worksheet in Appendix F of the LID BMP Design Handbook. Second, design the LID BMP to meet the required V_{BMP} using a method approved by the Copermittee. Utilize the worksheets found in the LID BMP Design Handbook or consult with your Copermittee to assist you in correctly sizing your LID BMPs. Complete Table D.3 below to document the Design Capture Volume and the Proposed Volume for each LID BMP. Provide the completed design procedure sheets for each LID BMP in Appendix 6. You may add additional rows to the table below as needed.

Table D.3 DCV Calculations for LID BMPs

DMA Type/ID	DMA Area (square feet)	Post-Project Surface Type	Effective Impervious Fraction, I_f	DMA Runoff Factor	DMA Areas x Runoff Factor	Design Storm Depth (in)	Design Capture Volume, V_{BMP} (cubic feet)	Proposed Volume on Plans (cubic feet)*
	[A]		[B]	[C]	[A] x [C]			
A-1	174,240	Roofs/Conc/Asphalt	1.00	0.89	155,422.1	0.62	8030.1	8,160
A-2	15,682	Ornamental Landscaping	0.10	0.11	1,732.2	0.62	89.5	
	189,922				157,154	0.62	8,120	8,160

[B], [C] is obtained as described in Section 2.3.1 of the WQMP Guidance Document

[E] is obtained from Exhibit A in the WQMP Guidance Document

[G] is obtained from a design procedure sheet, such as in LID BMP Design Handbook and placed in Appendix 6

*Proposed volume = Installed Storage Volume + MWS Linear Static Capacity
 = 92 cu-ft + 8,068 cu-ft = 8,160 cu-ft

Section E: Alternative Compliance (LID Waiver Program)

LID BMPs are expected to be feasible on virtually all projects. Where LID BMPs have been demonstrated to be infeasible as documented in Section D, other Treatment Control BMPs must be used (subject to LID waiver approval by the Copermittee). Check one of the following Boxes:

LID Principles and LID BMPs have been incorporated into the site design to fully address all Drainage Management Areas. No alternative compliance measures are required for this project and thus this Section is not required to be completed.

- Or -

The following Drainage Management Areas are unable to be addressed using LID BMPs. A site-specific analysis demonstrating technical infeasibility of LID BMPs has been approved by the Co-Permittee and included in Appendix 5. Additionally, no downstream regional and/or sub-regional LID BMPs exist or are available for use by the project. The following alternative compliance measures on the following pages are being implemented to ensure that any pollutant loads expected to be discharged by not incorporating LID BMPs, are fully mitigated.

E.1 Identify Pollutants of Concern

Utilizing Table A.1 from Section A above which noted your project's receiving waters and their associated EPA approved 303(d) listed impairments, cross reference this information with that of your selected Priority Development Project Category in Table E.1 below. If the identified General Pollutant Categories are the same as those listed for your receiving waters, then these will be your Pollutants of Concern and the appropriate box or boxes will be checked on the last row. The purpose of this is to document compliance and to help you appropriately plan for mitigating your Pollutants of Concern in lieu of implementing LID BMPs.

Table E.1 Potential Pollutants by Land Use Type

Priority Project Categories and/or Project Features (check those that apply)	General Pollutant Categories							
	Bacterial Indicators	Metals	Nutrients	Pesticides	Toxic Organic Compounds	Sediments	Trash & Debris	Oil & Grease
<input type="checkbox"/> Detached Residential Development	P	N	P	P	N	P	P	P
<input type="checkbox"/> Attached Residential Development	P	N	P	P	N	P	P	P ⁽²⁾
<input checked="" type="checkbox"/> Commercial/Industrial Development	P ⁽³⁾	P	P ⁽¹⁾	P ⁽¹⁾	P ⁽⁵⁾	P ⁽¹⁾	P	P
<input type="checkbox"/> Automotive Repair Shops	N	P	N	N	P ^(4, 5)	N	P	P
<input type="checkbox"/> Restaurants (>5,000 ft ²)	P	N	N	N	N	N	P	P
<input type="checkbox"/> Hillside Development (>5,000 ft ²)	P	N	P	P	N	P	P	P
<input checked="" type="checkbox"/> Parking Lots (>5,000 ft ²)	P ⁽⁶⁾	P	P ⁽¹⁾	P ⁽¹⁾	P ⁽⁴⁾	P ⁽¹⁾	P	P
<input type="checkbox"/> Retail Gasoline Outlets	N	P	N	N	P	N	P	P
Project Priority Pollutant(s) of Concern	<input type="checkbox"/>	<input checked="" type="checkbox"/>	<input type="checkbox"/>	<input type="checkbox"/>	<input type="checkbox"/>	<input type="checkbox"/>	<input checked="" type="checkbox"/>	<input checked="" type="checkbox"/>

P = Potential

N = Not Potential

⁽¹⁾ A potential Pollutant if non-native landscaping exists or is proposed onsite; otherwise not expected

⁽²⁾ A potential Pollutant if the project includes uncovered parking areas; otherwise not expected

⁽³⁾ A potential Pollutant is land use involving animal waste

⁽⁴⁾ Specifically petroleum hydrocarbons

⁽⁵⁾ Specifically solvents

⁽⁶⁾ Bacterial indicators are routinely detected in pavement runoff

E.2 Stormwater Credits

Projects that cannot implement LID BMPs but nevertheless implement smart growth principles are potentially eligible for Stormwater Credits. Utilize Table 3-8 within the WQMP Guidance Document to identify your Project Category and its associated Water Quality Credit. If not applicable, write N/A.

Table E.2 Water Quality Credits

Qualifying Project Categories	Credit Percentage ²
N/A	
Total Credit Percentage¹	

¹Cannot Exceed 50%

²Obtain corresponding data from Table 3-8 in the WQMP Guidance Document

E.3 Sizing Criteria

After you appropriately considered Stormwater Credits for your project, utilize Table E.3 below to appropriately size them to the DCV, or Design Flow Rate, as applicable. Please reference Chapter 3.5.2 of the WQMP Guidance Document for further information.

Table E.3 Treatment Control BMP Sizing

DMA Type/ ID	DMA Area (square feet)	Post- Project Surface Type	Effective Imp Fraction, I_f	DMA Runoff Factor	DMA Area x Runoff Factor				
	[A]		[B]	[C]	[A] x [C]				
N/A	N/A	N/A	N/A	N/A	N/A				
						<i>Design Storm Depth (in)</i>	<i>Minimum Design Capture Volume (cubic feet)</i>	<i>Total Storm Water Credit % Reduction</i>	<i>Proposed Volume or Flow on Plans (cubic feet or cfs)</i>

[B], [C] is obtained as described in Section 2.3.1 from the WQMP Guidance Document

[E] is obtained from Exhibit A in the WQMP Guidance Document

[G] is for Flow-Based Treatment Control BMPs [G] = 43,560, for Volume-Based Control Treatment BMPs, [G] = 12

[H] is from the Total Credit Percentage as Calculated from Table E.2 above

[I] as obtained from a design procedure sheet from the BMP manufacturer and should be included in Appendix 6

E.4 Treatment Control BMP Selection

Treatment Control BMPs typically provide proprietary treatment mechanisms to treat potential pollutants in runoff, but do not sustain significant biological processes. Treatment Control BMPs must have a removal efficiency of a medium or high effectiveness as quantified below:

- **High:** equal to or greater than 80% removal efficiency
- **Medium:** between 40% and 80% removal efficiency

Such removal efficiency documentation (e.g., studies, reports, etc.) as further discussed in Chapter 3.5.2 of the WQMP Guidance Document, must be included in Appendix 6. In addition, ensure that proposed Treatment Control BMPs are properly identified on the WQMP Site Plan in Appendix 1.

Table E.4 Treatment Control BMP Selection

Selected Treatment Control BMP Name or ID ¹	Priority Pollutant(s) of Concern to Mitigate ²	Removal Efficiency Percentage ³
Modular Wetlands System	Metals	38%-69%
Modular Wetlands System	Trash & Debris/TSS	85%
Modular Wetlands System	Oil & Grease	95%

¹ Treatment Control BMPs must not be constructed within Receiving Waters. In addition, a proposed Treatment Control BMP may be listed more than once if they possess more than one qualifying pollutant removal efficiency.

² Cross Reference Table E.1 above to populate this column.

³ As documented in a Co-Permittee Approved Study and provided in Appendix 6.

Section F: Hydromodification

F.1 Hydrologic Conditions of Concern (HCOC) Analysis

Once you have determined that the LID design is adequate to address water quality requirements, you will need to assess if the proposed LID Design may still create a HCOC. Review Chapters 2 and 3 (including Figure 3-7) of the WQMP Guidance Document to determine if your project must mitigate for Hydromodification impacts. If your project meets one of the following criteria which will be indicated by the check boxes below, you do not need to address Hydromodification at this time. However, if the project does not qualify for Exemptions 1, 2 or 3, then additional measures must be added to the design to comply with HCOC criteria. This is discussed in further detail below in Section F.2.

HCOC EXEMPTION 1: The Priority Development Project disturbs less than one acre. The Copermitttee has the discretion to require a Project-Specific WQMP to address HCOCs on projects less than one acre on a case by case basis. The disturbed area calculation should include all disturbances associated with larger common plans of development.

Does the project qualify for this HCOC Exemption? Y N

If Yes, HCOC criteria do not apply.

HCOC EXEMPTION 2: The volume and time of concentration¹ of storm water runoff for the post-development condition is not significantly different from the pre-development condition for a 2-year return frequency storm (a difference of 5% or less is considered insignificant) using one of the following methods to calculate:

- Riverside County Hydrology Manual
- Technical Release 55 (TR-55): Urban Hydrology for Small Watersheds (NRCS 1986), or derivatives thereof, such as the Santa Barbara Urban Hydrograph Method
- Other methods acceptable to the Co-Permittee

Does the project qualify for this HCOC Exemption? Y N

If yes, report results in Table F.1 below and provide your substantiated hydrologic analysis in Appendix 7.

Table F.1 Hydrologic Conditions of Concern Summary

	2 year – 24 hour		
	Pre-condition	Post-condition	% Difference
Time of Concentration (min)	N/A	N/A	N/A
Volume (Cubic Feet)	N/A	N/A	N/A

¹ Time of concentration is defined as the time after the beginning of the rainfall when all portions of the drainage basin are contributing to flow at the outlet.

HCOC EXEMPTION 3: All downstream conveyance channels to an adequate sump (for example, Prado Dam, Lake Elsinore, Canyon Lake, Santa Ana River, or other lake, reservoir or naturally erosion resistant feature) that will receive runoff from the project are engineered and regularly maintained to ensure design flow capacity; no sensitive stream habitat areas will be adversely affected; or are not identified on the Co-Permittees Hydromodification Sensitivity Maps.

Does the project qualify for this HCOC Exemption? Y N

If Yes, HCOC criteria do not apply and note below which adequate sump applies to this HCOC qualifier:

F.2 HCOC Mitigation

As an alternative to the HCOC Exemption Criteria above, HCOC criteria is considered mitigated if the project meets one of the following conditions, as indicated:

- a. Additional LID BMPS are implemented onsite or offsite to mitigate potential erosion or habitat impacts as a result of HCOCs. This can be conducted by an evaluation of site-specific conditions utilizing accepted professional methodologies published by entities such as the California Stormwater Quality Association (CASQA), the Southern California Coastal Water Research Project (SCCRWP), or other Co-Permittee approved methodologies for site-specific HCOC analysis.
- b. The project is developed consistent with an approved Watershed Action Plan that addresses HCOC in Receiving Waters.
- c. Mimicking the pre-development hydrograph with the post-development hydrograph, for a 2-year return frequency storm. Generally, the hydrologic conditions of concern are not significant, if the post-development hydrograph is no more than 10% greater than pre-development hydrograph. In cases where excess volume cannot be infiltrated or captured and reused, discharge from the site must be limited to a flow rate no greater than 110% of the pre-development 2-year peak flow.
- d. None of the above.

All pertinent documentation used in analysis of the items a, b or c can be found in Appendix 7.

The project site is located within the exempted HCOC area, as presented in the April 20, 2017 approved WAP/HCOC document. Refer to HCOC map provided in Appendix 7.

Section G: Source Control BMPs

Source control BMPs include permanent, structural features that may be required in your project plans — such as roofs over and berms around trash and recycling areas — and Operational BMPs, such as regular sweeping and “housekeeping”, that must be implemented by the site’s occupant or user. The MEP standard typically requires both types of BMPs. In general, Operational BMPs cannot be substituted for a feasible and effective permanent BMP. Using the Pollutant Sources/Source Control Checklist in Appendix 8, review the following procedure to specify Source Control BMPs for your site:

1. **Identify Pollutant Sources:** Review Column 1 in the Pollutant Sources/Source Control Checklist. Check off the potential sources of Pollutants that apply to your site.
2. **Note Locations on Project-Specific WQMP Exhibit:** Note the corresponding requirements listed in Column 2 of the Pollutant Sources/Source Control Checklist. Show the location of each Pollutant source and each permanent Source Control BMP in your Project-Specific WQMP Exhibit located in Appendix 1.
3. **Prepare a Table and Narrative:** Check off the corresponding requirements listed in Column 3 in the Pollutant Sources/Source Control Checklist. In the left column of Table G.1 below, list each potential source of runoff Pollutants on your site (from those that you checked in the Pollutant Sources/Source Control Checklist). In the middle column, list the corresponding permanent, Structural Source Control BMPs (from Columns 2 and 3 of the Pollutant Sources/Source Control Checklist) used to prevent Pollutants from entering runoff. **Add additional narrative** in this column that explains any special features, materials or methods of construction that will be used to implement these permanent, Structural Source Control BMPs.
4. **Identify Operational Source Control BMPs:** To complete your table, refer once again to the Pollutant Sources/Source Control Checklist. List in the right column of your table the Operational BMPs that should be implemented as long as the anticipated activities continue at the site. Copermittee stormwater ordinances require that applicable Source Control BMPs be implemented; the same BMPs may also be required as a condition of a use permit or other revocable Discretionary Approval for use of the site.

Table G.1 Permanent and Operational Source Control Measures

Potential Sources of Runoff pollutants	Permanent Structural Source Control BMPs	Operational Source Control BMPs
A. On-site storm drain inlets	<ul style="list-style-type: none"> Mark all inlets with the words “Only Rain Down the Storm Drain” or similar. 	<ul style="list-style-type: none"> Maintain and periodically repaint or replace inlet markings annually. Provide stormwater pollution prevention information to new site owners, lessees, or operators upon occupancy and annually thereafter. See CASQA fact sheet SC-44 for “Drainage System Maintenance,” included in Appendix of this document. Include the following lease agreements: “Tenant shall not allow anyone to discharge anything to storm drain or to store or deposit materials so as to create a potential discharge to storm drains.”

Potential Sources of Runoff pollutants	Permanent Structural Source Control BMPs	Operational Source Control BMPs
B. Interior floor drains and elevator shaft sump pumps	<ul style="list-style-type: none"> Interior floor drains and elevator shaft sump pumps will be plumbed to sanitary sewer. 	<ul style="list-style-type: none"> Inspect and maintain drains semi-annually to prevent blockages and overflow.
D2. Landscape / Outdoor Pesticide Use	<ul style="list-style-type: none"> Landscape plans will minimize irrigation and runoff, to promote surface infiltration where appropriate, and to minimize the use of fertilizers and pesticides that can contribute to stormwater pollution. Pest-resistant plans will be used adjacent to hardscape. The landscape plans will consider plants appropriate to the site soils, slopes, climate, sun, wind, rain, land use, air movement, ecological consistency, and plant interactions. 	<ul style="list-style-type: none"> Maintain landscaping only using minimum pesticides, when needed. See Appendix 10 for "Landscape and Gardening" brochure by RCFlood. Provide Integrated Pest Management (IPM) information to new owners, lessees and operators upon occupancy and annually thereafter. IPM is an effective and environmentally sensitive approach to pest management.
G. Refuse Areas	<ul style="list-style-type: none"> Site refuse will be handled by contractor on a weekly basis. Signs will be posted on or near dumpsters with the words "Do not dump hazardous materials here" or similar. 	<ul style="list-style-type: none"> A minimum of two receptacles will be provided and located indoors. Receptacles are to be inspected daily and repairs or replacements to leaky receptacles will be completed immediately. Receptacles are to remain covered when not in use. Dumping of liquid or hazardous wastes is prohibited. A "no hazardous materials" sign will be posted. Spills will be cleaned immediately upon discovery. Spill control materials will be available onsite. See Appendix 10 for CASQA fact sheet SC-34 for "Waste Handling and Disposal."
H. Industrial processes	<ul style="list-style-type: none"> All process activities to be performed indoors. No processes to drain to exterior or to storm drain system. 	<ul style="list-style-type: none"> See Appendix 10 for CASQA fact sheet SC-10 for "Non-Stormwater Discharges"
O. Miscellaneous Drain or Wash Water or Other Sources	<ul style="list-style-type: none"> Drainage sumps on-site shall feature a sediment sump to reduce the quantity of sediment in pumped water. 	
P. Plazas, sidewalks, and parking lots		<ul style="list-style-type: none"> Sweep plazas, sidewalks, and parking lots monthly to prevent accumulation of litter and debris. Collect debris from pressure washing to prevent entry into the storm drain system. Collect washwater containing any cleaning agent or degreaser and discharge to the sanitary sewer not to a storm drain.

Section H: Construction Plan Checklist

Populate Table H.1 below to assist the plan checker in an expeditious review of your project. The first two columns will contain information that was prepared in previous steps, while the last column will be populated with the corresponding plan sheets. This table is to be completed with the submittal of your final Project-Specific WQMP.

Table H.1 Construction Plan Cross-reference

BMP No. or ID	BMP Identifier and Description	Corresponding Plan Sheet(s)	Latitude	Longitude
A	On-site storm drain inlets	Conceptual Grading Plan Sheets 1-3	---	---
B	Interior floor drains and elevator shaft sump pumps	N/A	---	---
D2	Landscape / Outdoor Pesticide Use	On-site Landscape Improvement Plans	---	---
G	Refuse Areas	Conceptual Grading Plan Sheet 1	---	---
H	Industrial processes	Grading Plans (indoors, if any)	---	---
P	Plazas, sidewalks, and parking lots	Conceptual Grading Plan Sheets 1-3	---	---
MWS-A	Modular Wetlands System	Conceptual Grading Plan Sheets 1-3	33.856078	-117.244071
STC-A	Underground Detention	Conceptual Grading Plan Sheets 1-3	33.856068	-117.244292

Note that the updated table — or Construction Plan WQMP Checklist — is **only a reference tool** to facilitate an easy comparison of the construction plans to your Project-Specific WQMP. Co-Permittee staff can advise you regarding the process required to propose changes to the approved Project-Specific WQMP.

Section I: Operation, Maintenance and Funding

The Copermittee will periodically verify that Stormwater BMPs on your site are maintained and continue to operate as designed. To make this possible, your Copermittee will require that you include in Appendix 9 of this Project-Specific WQMP:

1. A means to finance and implement facility maintenance in perpetuity, including replacement cost.
2. Acceptance of responsibility for maintenance from the time the BMPs are constructed until responsibility for operation and maintenance is legally transferred. A warranty covering a period following construction may also be required.
3. An outline of general maintenance requirements for the Stormwater BMPs you have selected.
4. Figures delineating and designating pervious and impervious areas, location, and type of Stormwater BMP, and tables of pervious and impervious areas served by each facility. Geo-locating the BMPs using a coordinate system of latitude and longitude is recommended to help facilitate a future statewide database system.
5. A separate list and location of self-retaining areas or areas addressed by LID Principles that do not require specialized O&M or inspections but will require typical landscape maintenance as noted in Chapter 5, pages 85-86, in the WQMP Guidance. Include a brief description of typical landscape maintenance for these areas.

Your local Co-Permittee will also require that you prepare and submit a detailed Stormwater BMP Operation and Maintenance Plan that sets forth a maintenance schedule for each of the Stormwater BMPs built on your site. An agreement assigning responsibility for maintenance and providing for inspections and certification may also be required.

Details of these requirements and instructions for preparing a Stormwater BMP Operation and Maintenance Plan are in Chapter 5 of the WQMP Guidance Document.

Maintenance Mechanism: City of Perris: Covenant and Agreement
Water Quality Management Plan and Urban Runoff BMP Transfer, Access and Maintenance Agreement

Will the proposed BMPs be maintained by a Home Owners' Association (HOA) or Property Owners Association (POA)?

Y N

Include your Operation and Maintenance Plan and Maintenance Mechanism in Appendix 9. Additionally, include all pertinent forms of educational materials for those personnel that will be maintaining the proposed BMPs within this Project-Specific WQMP in Appendix 10.

This section will be completed and addressed at the time of the final WQMP Submittal

Appendix 1: Maps and Site Plans

Location Map, WQMP Site Plan and Receiving Waters Map

Legend

↓ PROJECT SITE

PROJECT SITE

LAKE PERRIS





1 mi

VICINITY MAP

North Nance Trailer Yard



Legend

-  DRAINAGE PATH
-  PROJECT SITE

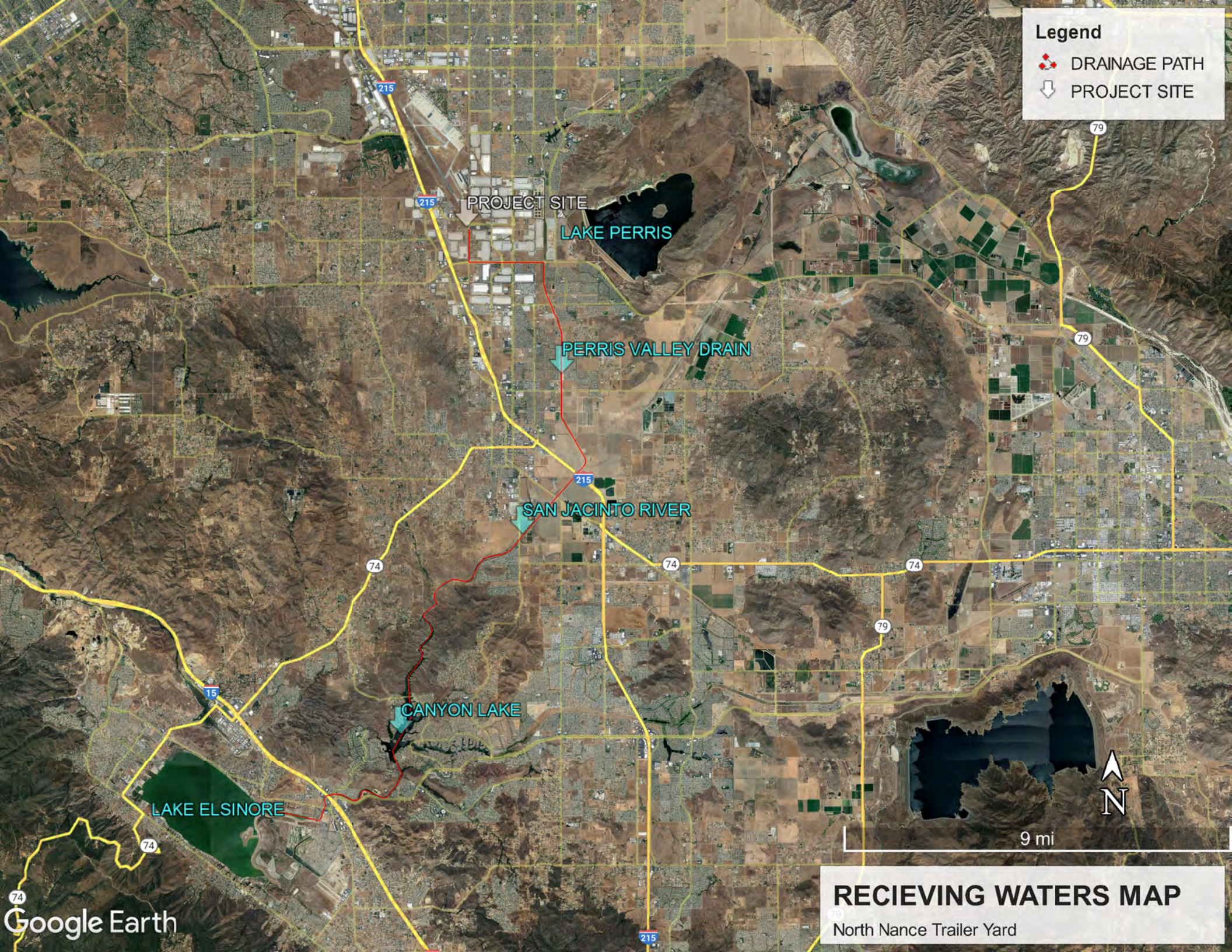

PROJECT SITE

LAKE PERRIS

PERRIS VALLEY DRAIN

SAN JACINTO RIVER

CANYON LAKE

LAKE ELSINORE

RECIEVING WATERS MAP

North Nance Trailer Yard

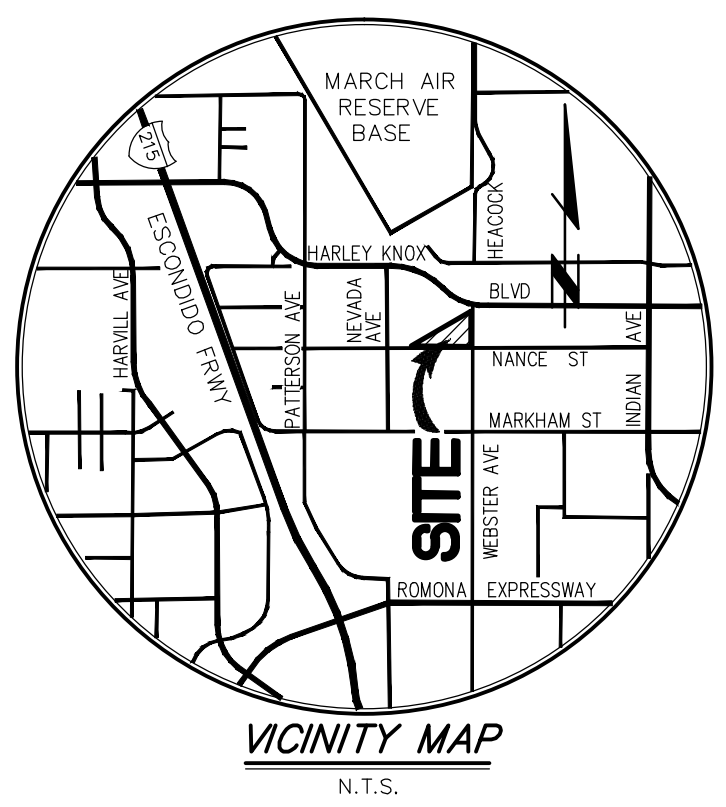

LEGEND

- ① EDUCATIONAL MATERIAL
- ② STORM DRAIN STENCIL
- ③ STORMTECH MC-3500 DETENTION CHAMBERS
- ④ PARKING LOT MAINTENANCE (SWEEPING)
- ⑤ PROPRIETARY BIOTREATMENT UNIT (MODULAR WETLANDS SYSTEM)
- ⑥ DRAIN INSERT(S)
- ⑦ SUMP PUMP
- ⑧ SELF-TREATING LANDSCAPE
- ⑨ DIVERSION STRUCTURE

NOTE:

- BOUNDARY
- SUBAREAS
- SURFACE FLOW LINE
- SD FLOW LINE

DMA A
DMA B
DMA C

LANDSCAPE AREA



SAMPLE STORM DRAIN STENCIL

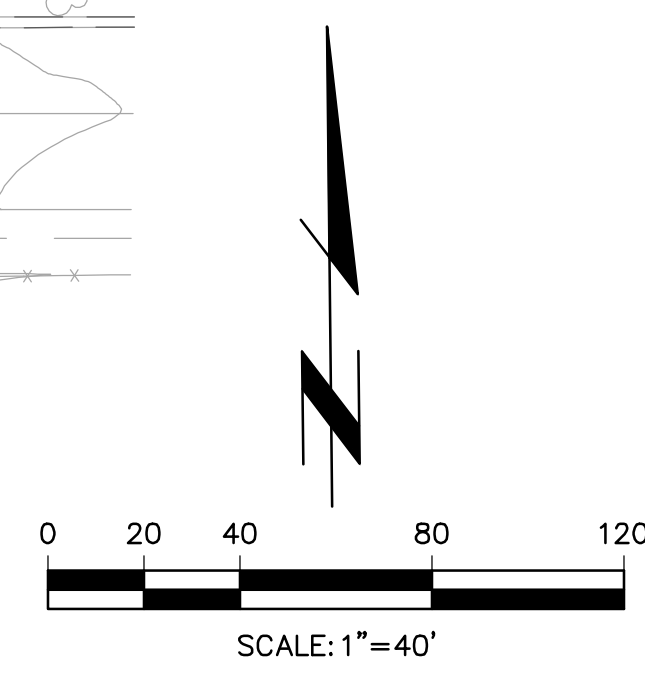
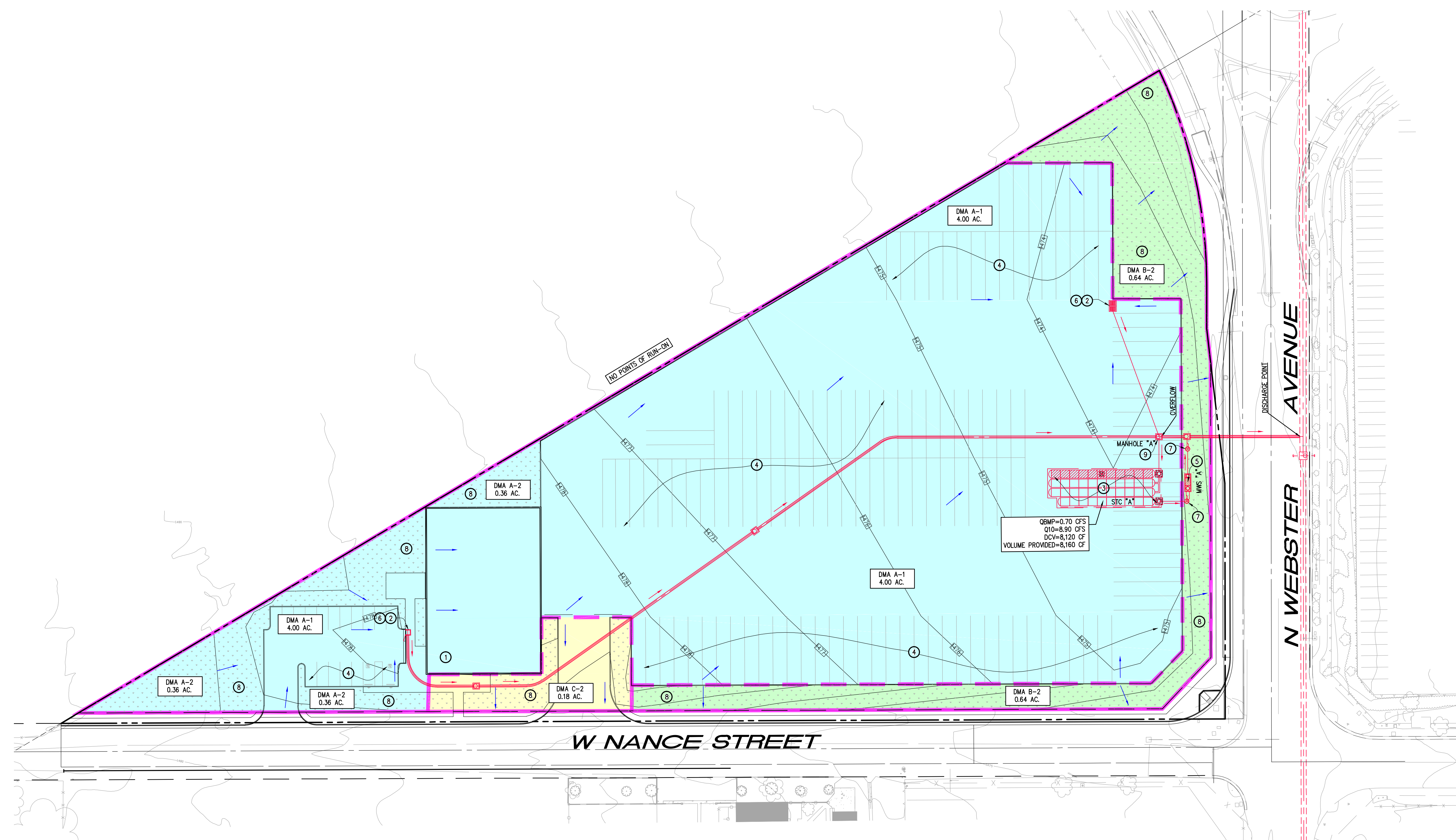

DMA Name or ID	Surface Type(s)	Area (Sq. Ft.)	Area (Acres)	DMA Type
A-1	Roofs/Conc/Asphalt	174,240	4.00	Type D
A-2	Ornamental Landscaping	15,682	0.36	Type D
B-2	Ornamental Landscaping	27,878	0.64	Type A
C-2	Ornamental Landscaping	7,841	0.18	Type A

DMA	AREA (ACRES)	DCV (CF)	MODULAR WETLANDS SYSTEM (MWS)		MC-3500 STORMTECH CHAMBERS		TOTAL VOLUME PROVIDED (CF)	
			MWS MODEL	LINEAR STATIC CAPACITY (CF)	DETENTION REQUIRED (CF)	DETENTION PROVIDED (CF)		# OF CHAMBERS
A	4.36	8,120	MWS-L-4-13	92	8,028	8,068	43	8,160
TOTAL	4.36	8,120		92	8,028	8,068	43	8,160

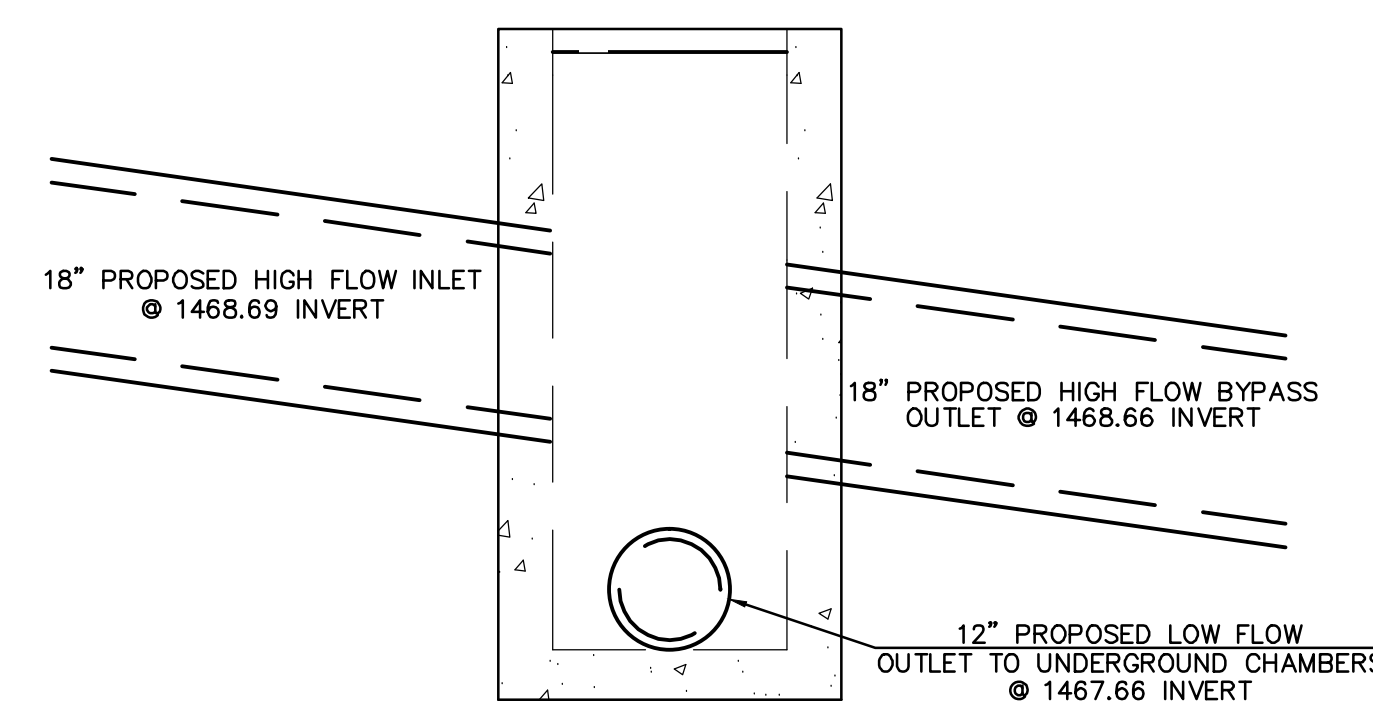
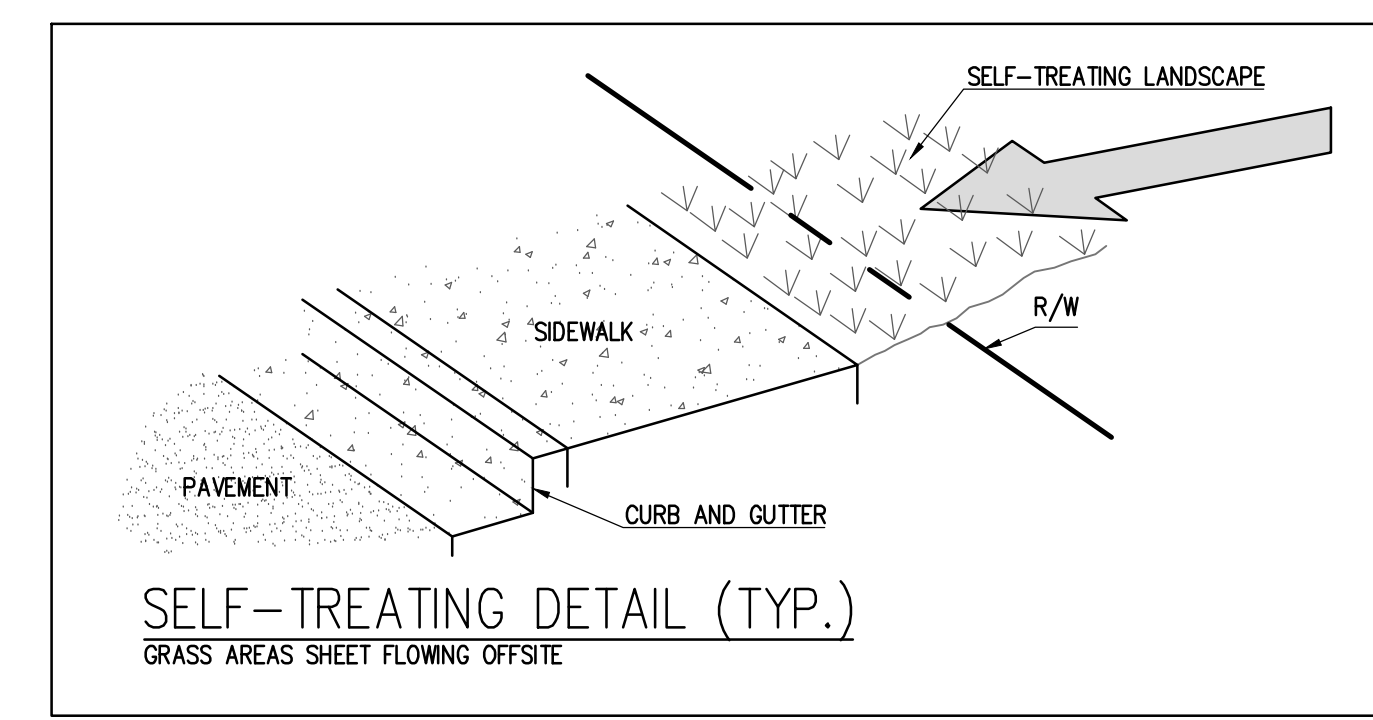

DIVERSION MANHOLE 'A'
N.T.S.

CITY OF PERRIS
PUBLIC WORKS DEPARTMENT

BMP SITE MAP

NORTH NANCE TRAILER YARD
NANCE STREET AND WEBSTER AVENUE

Prepared for: LAKE CREEK INDUSTRIAL LLC
1302 BRITANY CROSS ROAD
SANTA ANA, CA 92705
PHONE: (949) 910-4616

Prepared by: **Tai** Thienes Engineering, Inc.
CIVIL ENGINEERING - LAND SURVEYING
14340 FIRESTONE BOULEVARD
LA BREA, CALIFORNIA 90639
PH: (714) 521-4811 FAX: (714) 521-4773

Designed by: _____ Date: _____
Checked by: _____ Date: _____
Designed by: _____ Date: _____
Checked by: _____ Date: _____

Approved by: _____ Date: _____
Public Works Director R.C.E.

Sheet **1** of **2** Sheets

4108 / 1 OF 2 SHEET

Last Update: 7/22/22
0:14100-4199_4108_V108BMPSTEMP.dwg

**BIO CLEAN FULL CAPTURE FILTER WITH TROUGH SYSTEM
FOR USE IN CURB INLETS**

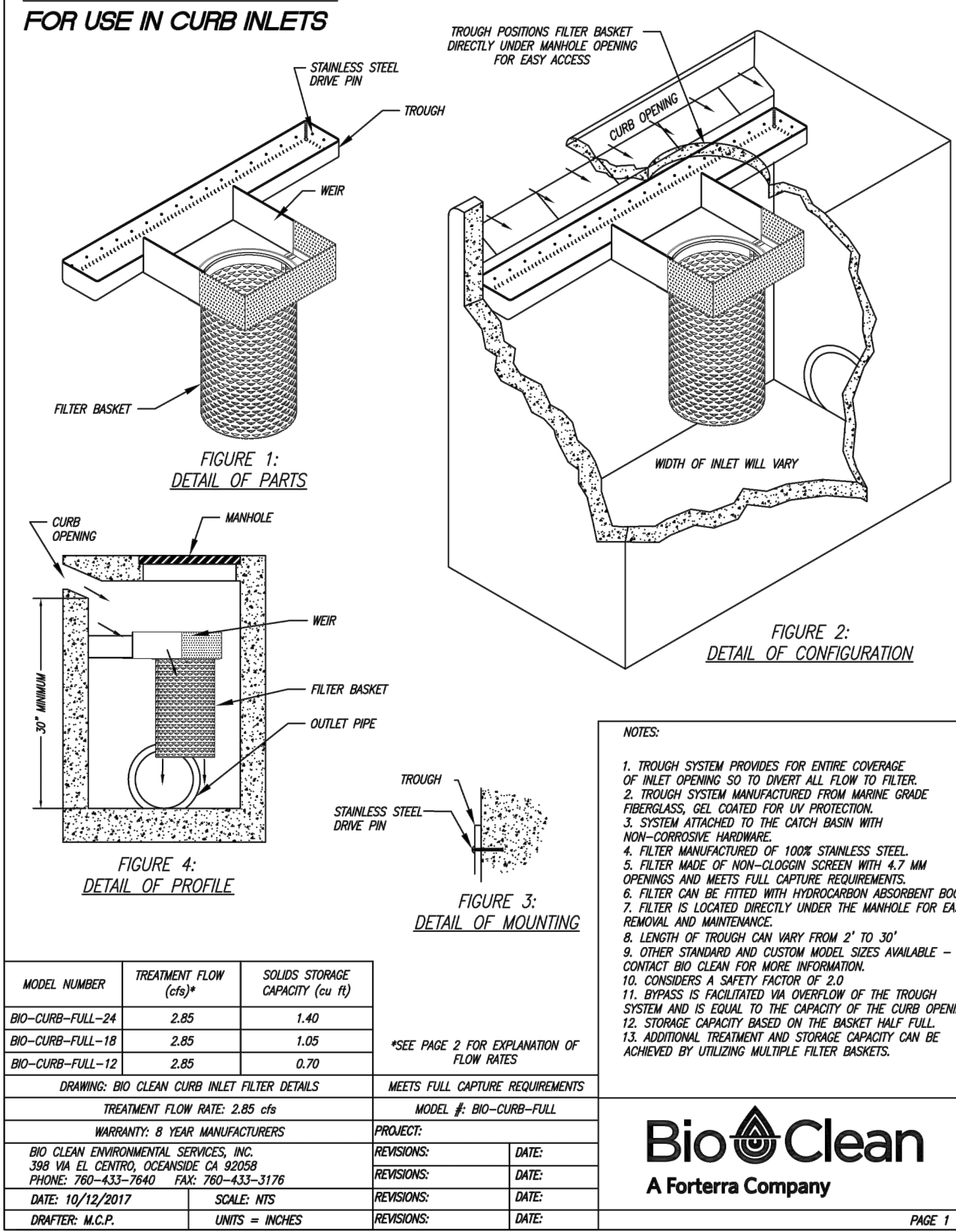

MODEL #	TREATMENT FLOW (GPM)	SOLIDS STORAGE CAPACITY (cu ft)
BIO-CURB-FULL-24	2.85	1.40
BIO-CURB-FULL-18	2.85	1.05
BIO-CURB-FULL-12	2.85	0.70

NOTE: SEE PAGE 2 FOR EXPLANATION OF FLOW RATES.

**BIO CLEAN FULL CAPTURE FILTER
FOR USE IN GRATE INLETS**

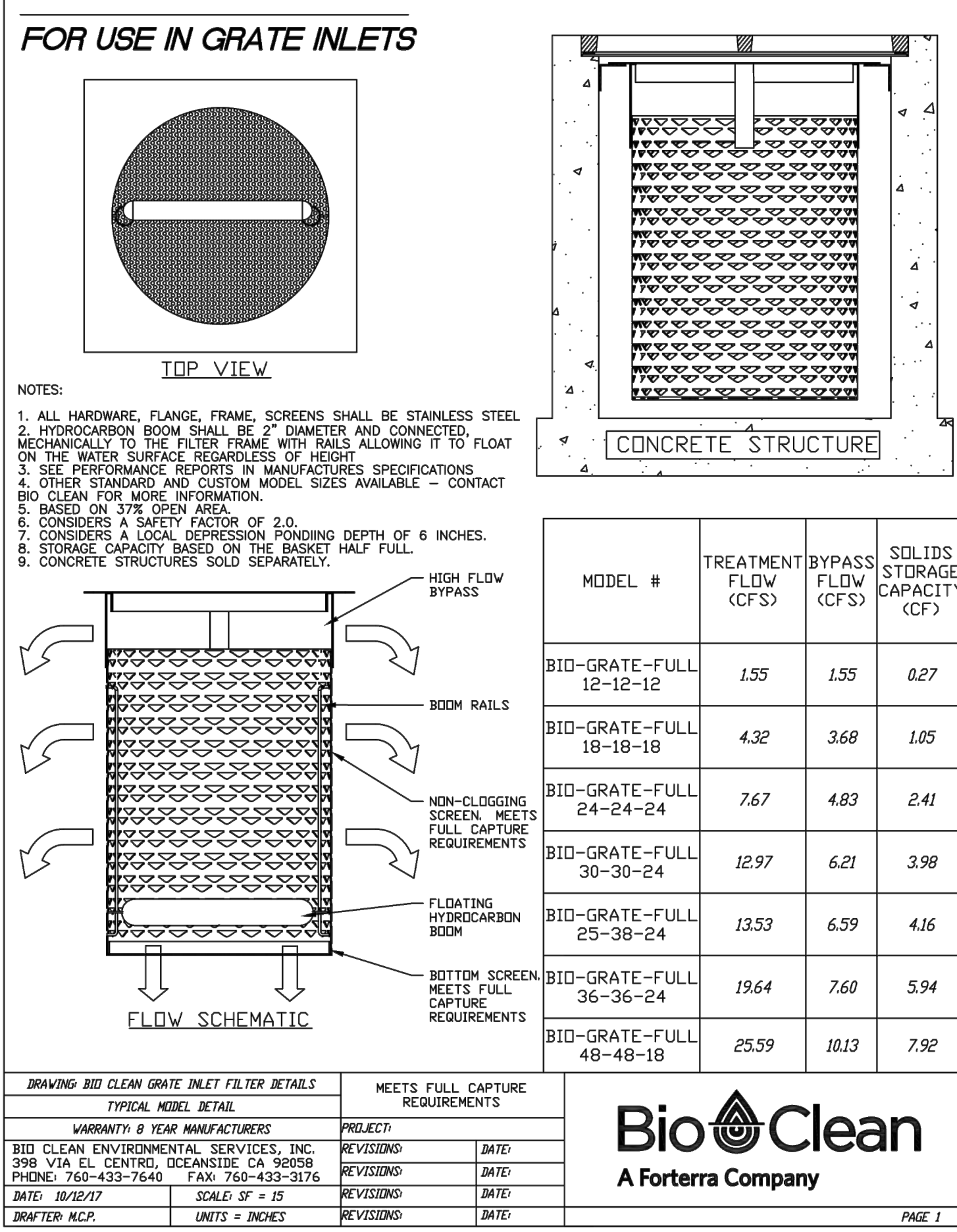

MODEL #	TREATMENT FLOW (CFD)	BYPASS FLOW (CFD)	SOLIDS STORAGE CAPACITY (CF)
BIO-GRATE-FULL-12-12-12	1.55	1.55	0.27
BIO-GRATE-FULL-18-18-18	4.32	3.68	1.05
BIO-GRATE-FULL-24-24-24	7.67	4.83	2.41
BIO-GRATE-FULL-30-30-24	12.97	6.21	3.98
BIO-GRATE-FULL-25-38-24	13.53	6.59	4.16
BIO-GRATE-FULL-36-36-24	19.64	7.60	5.94
BIO-GRATE-FULL-48-48-18	25.59	10.13	7.92

NOTE: DRAWING BIO-CLEAN GRATE INLET FILTER DETAILS MEETS FULL CAPTURE REQUIREMENTS.

SITE SPECIFIC DATA

PROJECT NUMBER	717.996
PROJECT NAME	PERRIS TRAILER YARD
PROJECT LOCATION	PERRIS, CA
STRUCTURE ID	N/A

TREATMENT REQUIRED:

VOLUME BASED (CF)	8753	FLOW BASED (CFS)	N/A
TREATMENT VOL. AVAILABLE (FT)	N/A	OFFLINE	N/A
PEAK BYPASS REQUIRED (CFS) - IF APPLICABLE	N/A	OFFLINE	N/A
PIPE DATA I.E. MATERIAL	PVC	DIAMETER	2"
INLET PIPE	-3.00		
RETURN PIPE	-1.60		
OUTLET PIPE	-5.08		
PRE-TREATMENT	BIOFILTRATION	DISCHARGE	
RIM ELEVATION	0.00		
SURFACE LOAD	PEDESTRIAN		
FRAME & COVER	#30" OPEN PLANTER	#24"	
WETLAND MEDIA VOLUME (CY)			3.77
ORIFICE SIZE (DIA. INCHES)			#0.86"

INSTALLATION NOTES:

- CONTRACTOR TO PROVIDE ALL LABOR, EQUIPMENT, MATERIALS AND INCIDENTALS REQUIRED TO OFFLOAD AND INSTALL THE SYSTEM AND APPURTENANCES IN ACCORDANCE WITH THIS DRAWING AND THE MANUFACTURER'S SPECIFICATIONS, UNLESS OTHERWISE STATED IN THE PROJECT ENGINEER'S RECOMMENDED BASE SPECIFICATIONS.
- UNIT MUST BE INSTALLED ON LEVEL BASE. MANUFACTURER RECOMMENDS A MINIMUM 6" LEVEL ROCK BASE UNLESS SPECIFIED BY THE PROJECT ENGINEER. CONTRACTOR IS RESPONSIBLE FOR VERIFYING PROJECT ENGINEER'S RECOMMENDED BASE SPECIFICATIONS.
- CONTRACTOR TO SUPPLY AND INSTALL ALL EXTERNAL CONNECTING PIPES. ALL PIPES MUST BE FLUSH WITH INSIDE SURFACE OF CONCRETE (PIPES CANNOT INTRUDE BEYOND FLUSH). INVERT OF OUTFLOW PIPE MUST BE FLUSH WITH DISCHARGE CHAMBER FLOOR. ALL PIPES SHALL BE SEALED WATER TIGHT PER MANUFACTURER'S STANDARD CONNECTION DETAIL.
- CONTRACTOR RESPONSIBLE FOR INSTALLATION OF ALL PIPES, RISERS, MANHOLES, AND HATCHES. CONTRACTOR TO USE GROUT AND/OR BRICKS TO MATCH COVERS WITH FINISHED SURFACE UNLESS SPECIFIED OTHERWISE.
- VEGETATION SUPPLIED AND INSTALLED BY OTHERS. ALL UNITS WITH VEGETATION MUST HAVE DRIP OR SPRAY IRRIGATION SUPPLIED AND INSTALLED BY OTHERS.
- CONTRACTOR RESPONSIBLE FOR CONTACTING BIO CLEAN FOR ACTIVATION OF UNIT. MANUFACTURER'S WARRANTY IS VOID WITHOUT PROPER ACTIVATION BY A BIO CLEAN REPRESENTATIVE.

GENERAL NOTES:

- MANUFACTURER TO PROVIDE ALL MATERIALS UNLESS OTHERWISE NOTED.
- ALL DIMENSIONS, ELEVATIONS, SPECIFICATIONS AND CAPACITIES ARE SUBJECT TO CHANGE. FOR PROJECT SPECIFIC DRAWINGS DETAILING EXACT DIMENSIONS, WEIGHTS AND ACCESSORIES PLEASE CONTACT BIO CLEAN.

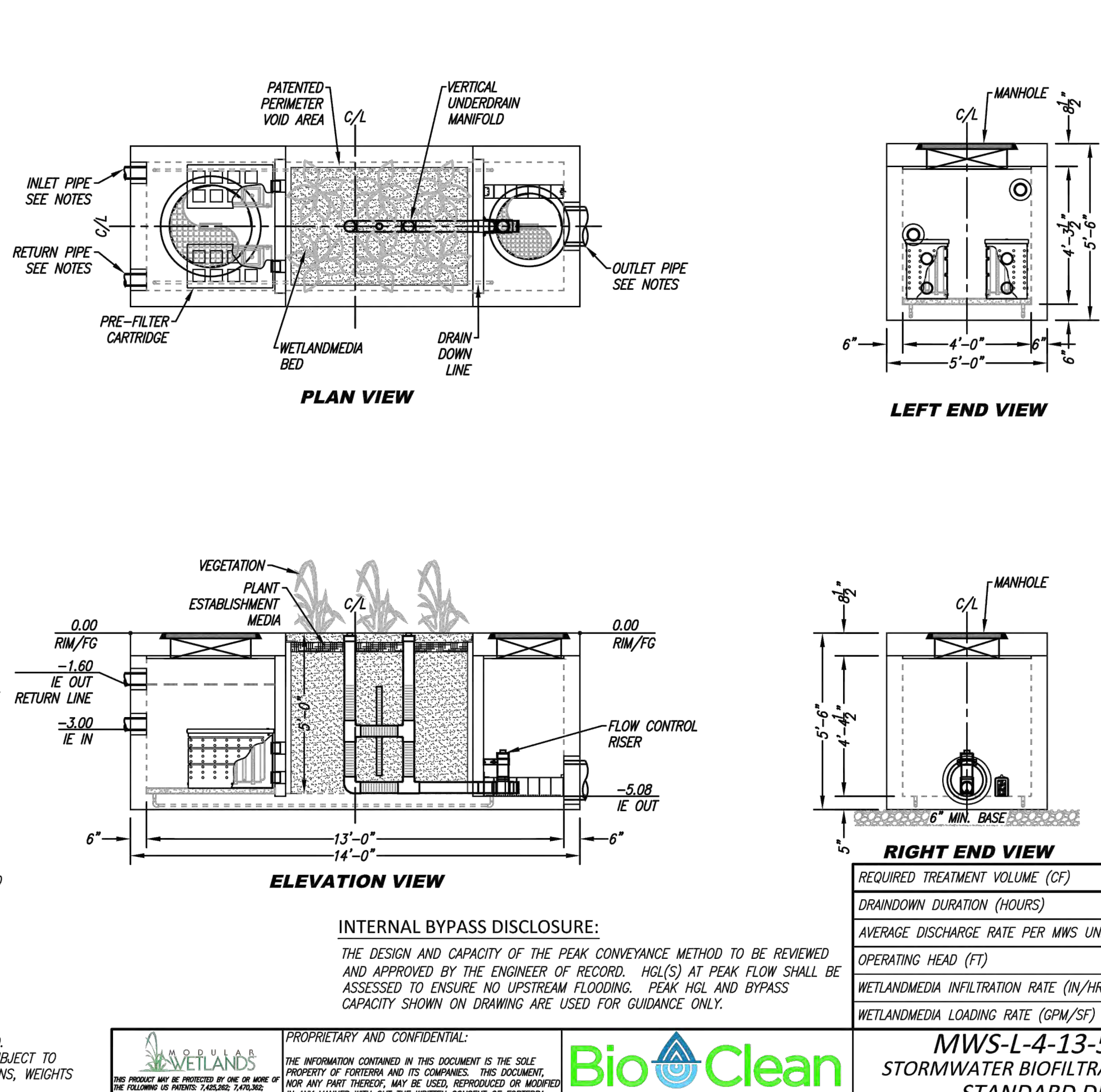

INTERNAL BYPASS DISCLOSURE:

THE DESIGN AND CAPACITY OF THE PEAK CONVEYANCE METHOD TO BE REVIEWED AND APPROVED BY THE ENGINEER OF RECORD. HGL(S) AT PEAK FLOW SHALL BE ASSESSED TO ENSURE NO UPSTREAM FLOODING. PEAK HGL AND BYPASS CAPACITY SHOWN ON DRAWING ARE USED FOR GUIDANCE ONLY.

REQUIRED TREATMENT VOLUME (CY)	8753
DRAINDOWN DURATION (HOURS)	67
AVERAGE DISCHARGE RATE PER MWS UNIT (GPM)	16.27
OPERATING HEAD (FT)	3.4
WETLAND MEDIA INFILTRATION RATE (IN/HR)	26
WETLAND MEDIA LOADING RATE (GPM/SF)	0.26

MWS-L-4-13-5'-0"-V
STORMWATER BIOFILTRATION SYSTEM
STANDARD DETAIL



STORMTECH MC-3500 CHAMBER

Designed to meet the most stringent industry performance standards for superior structural integrity while providing designers with a cost-effective method to save valuable land and protect water resources. The StormTech system is designed primarily to be used under parking lots, thus maximizing land usage for private (commercial) and public applications. StormTech chambers can also be used in conjunction with Green Infrastructure, thus enhancing the performance and extending the service life of these practices.

STORMTECH MC-3500 CHAMBER
(not to scale)

Nominal Chamber Specifications

Size (L x W x H)
90" x 71" x 45"
2,286 mm x 1,856 mm x 1,143 mm

Chamber Storage
105.9 ft³ (3.11 m³)

Min. Installed Storage*
175.0 ft³ (4.96 m³)

Weight
134 lbs (60.8 kg)

Shipping
15 chambers/pallet
7 end caps/pallet
7 pallets/truck

*Assumes a minimum of 12" (300 mm) of stone above, 6" (150 mm) of stone below, 6" (150 mm) of stone between chambers, 6" (150 mm) of stone between chambers/end caps and 40% stone porosity.

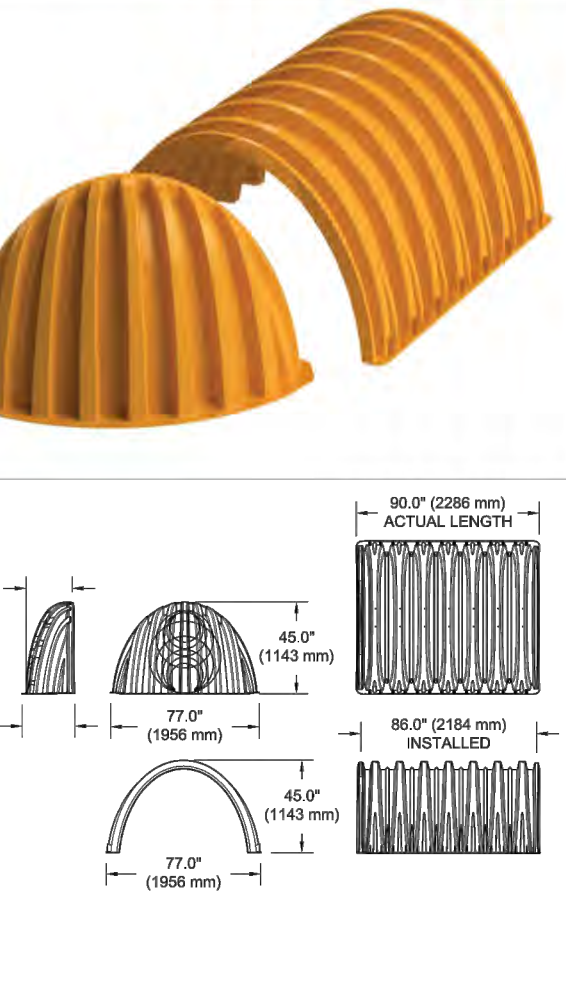

MC-3500 CHAMBER SPECIFICATION

STORAGE VOLUME PER CHAMBER FT³ (M³)

Chamber and Stone Foundation Depth (ft, (mm))	9" (230 mm)	12" (300 mm)	15" (375 mm)	18" (450 mm)
MC-3500 Chamber	105.9 (3.11)	175.0 (4.96)	179.9 (5.09)	184.9 (5.26)
MC-3500 End Cap	14.8 (0.42)	45.1 (1.28)	46.8 (1.32)	48.3 (1.37)

Note: Assumes 6" (150 mm) row spacing, 40% stone porosity, 12" (300 mm) stone above and includes the bare chambered cap volume.

AMOUNT OF STONE PER CHAMBER

ENGLISH TONS (gds)	9"	12"	15"	18"
MC-3500 Chamber	8.5 (8.0)	9.1 (8.5)	9.7 (9.0)	10.4 (7.4)
MC-3500 End Cap	3.9 (3.6)	4.1 (3.8)	4.3 (3.1)	4.5 (3.2)

VOLUME EXCAVATION PER CHAMBER YD³ (M³)

Stone Foundation Depth	9" (230 mm)	12" (300 mm)	15" (375 mm)	18" (450 mm)
MC-3500 Chamber	11.9 (8.1)	12.4 (8.5)	12.8 (8.4)	13.3 (10.2)
MC-3500 End Cap	4.0 (3.1)	4.1 (3.2)	4.3 (3.3)	4.4 (3.4)

Note: Assumes 6" (150 mm) of separation between chamber rows and 24" (600 mm) of cover. The volume of excavation will vary as depth of cover increases.

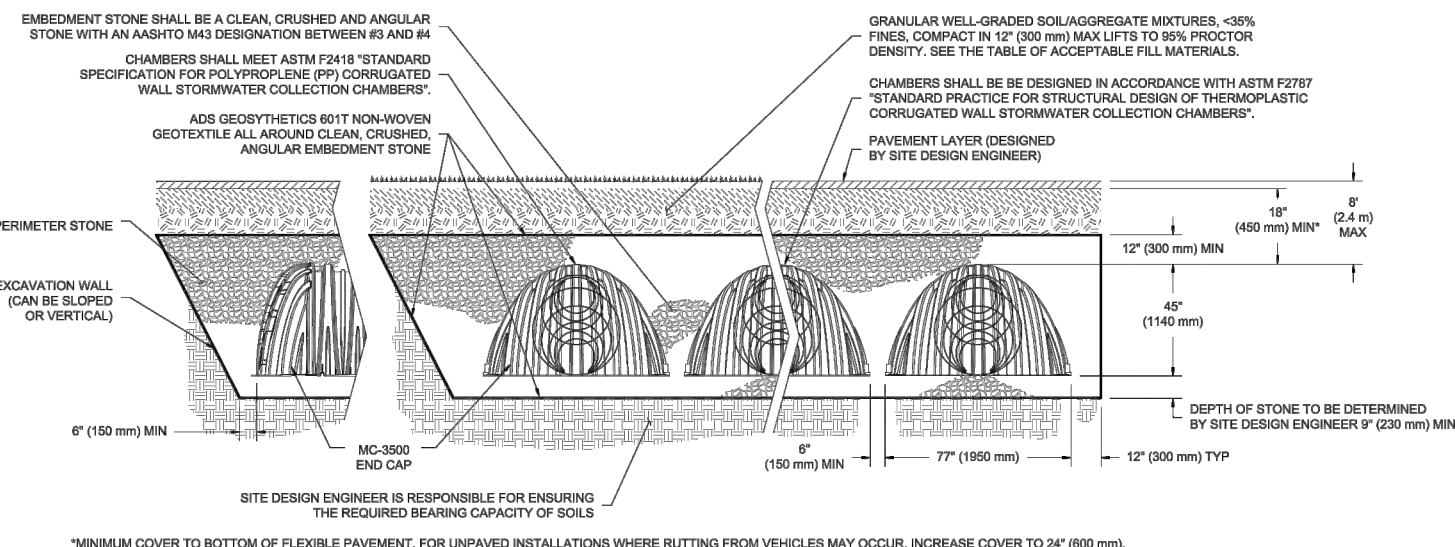

ADS DESIGN TOOL 2.0

Working on a project?
Visit us at www.stormtech.com
and utilize the StormTech Design Tool

For more information on the StormTech MC-3500 Chamber and other ADS products, please contact our Customer Service Representatives at 1-800-821-8710

THE MOST ADVANCED NAME IN WATER MANAGEMENT SOLUTIONS™

Advanced Drainage Systems, Inc.
4646 Truman Blvd., Newark, OH 43055
1-800-821-8710 www.ads-pipe.com

PREPARED FOR:
LAKE CREEK INDUSTRIAL LLC
1302 BRITANNY CROSS ROAD
SANTA ANA, CA 92705
PHONE: (949) 910-4616

PREPARED BY:
Tai Thienes Engineering, Inc.
CIVIL ENGINEERING - LAND SURVEYING
14144 FORESTONE BOULEVARD
LA BREA, CALIFORNIA 90639
PH: (714) 521-4811 FAX: (714) 521-4733

CITY OF PERRIS
PUBLIC WORKS DEPARTMENT
BMP SITE MAP
NORTH NANCE TRAILER YARD
NANCE STREET AND WEBSTER AVENUE

Designed by _____ Date _____
Checked by _____
Designed by _____ Date _____
Checked by _____ Date _____

Approved by _____ Date _____
Public Works Director R.C.E.

Sheet **2** of **2** Sheets

Appendix 2: Construction Plans

Grading and Drainage Plans

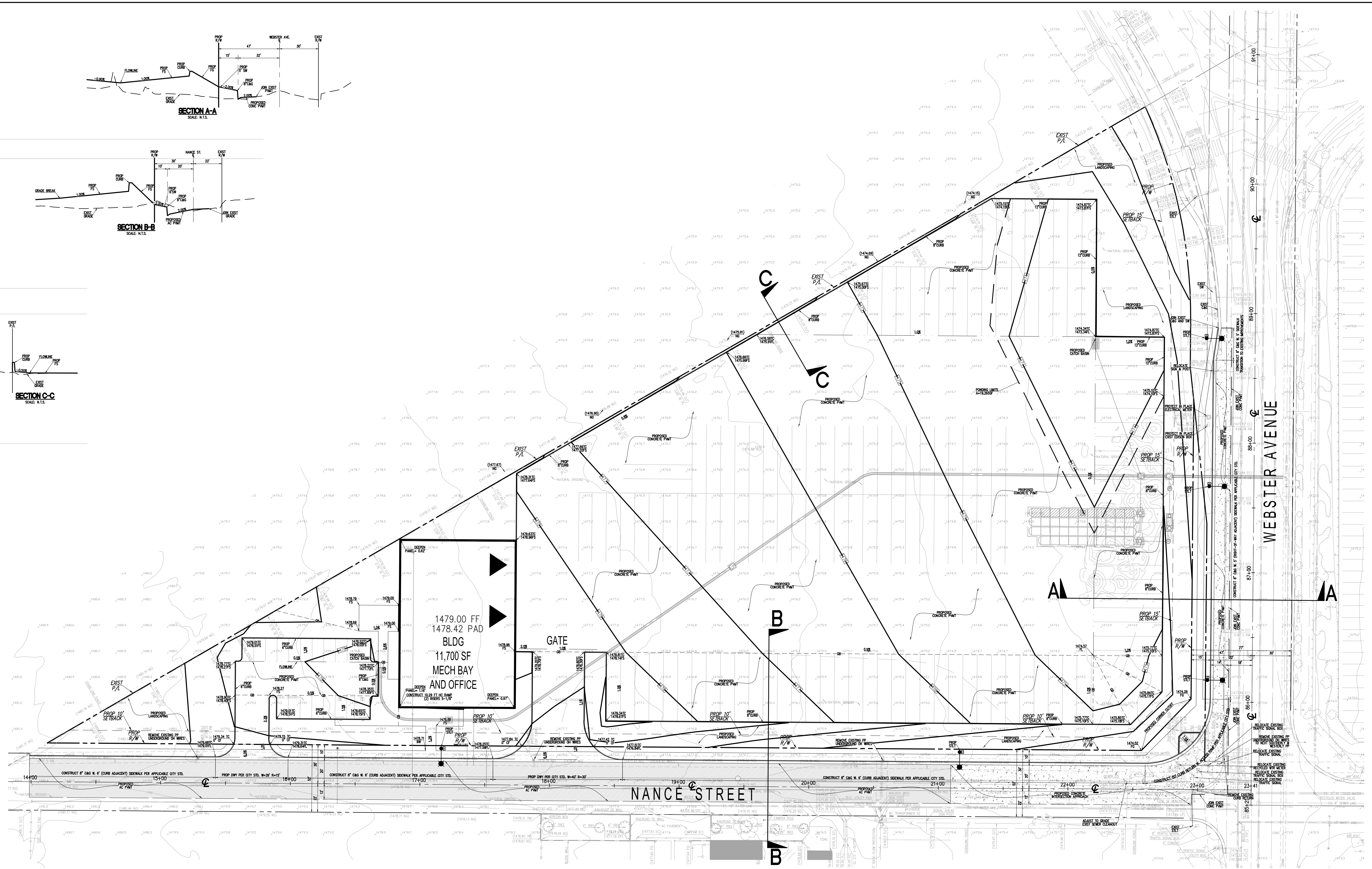
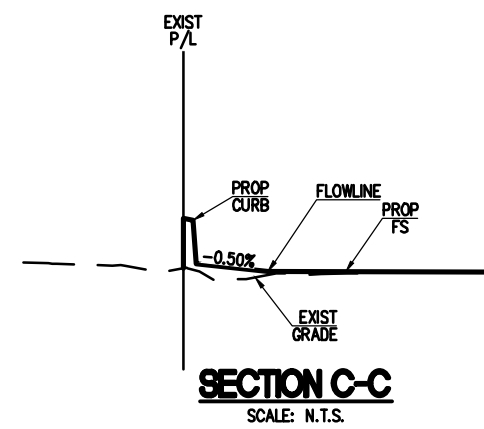
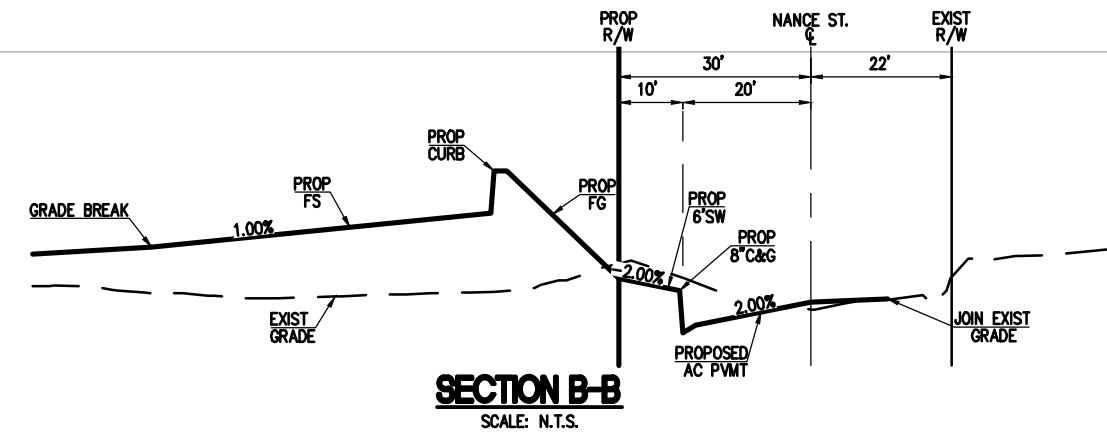
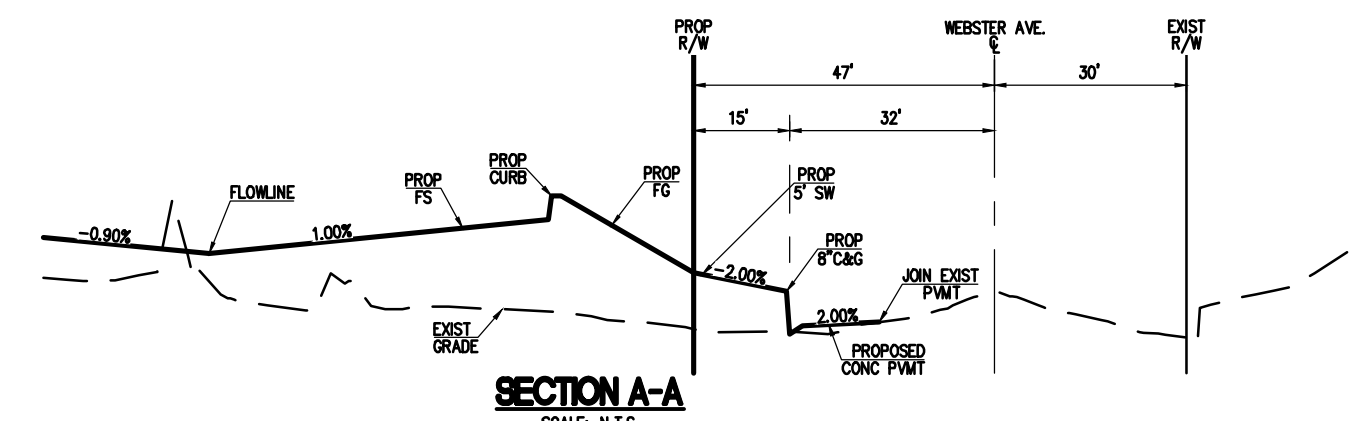

1479.00 FF
1478.42 PAD
BLDG
11,700 SF
MECH BAY
AND OFFICE

NANCE STREET

WEBSTER AVENUE

EARTHWORK BALANCE CALCULATIONS		6/23/2022
PROJECT:	LAKE CREEK INDUSTRIAL, LLC - PERRIS TRAILER YARD	
JOB#:	4108	
	QUANTITY	UNITS
K. SITE AREA:	225,577	SF
L. SUBSIDENCE FACTOR:	0.1	
M. SHRINKAGE FACTOR:	10.0	%
N. SITE STRIPPING FACTOR:	0.04	
O. OVEREXCAVATION:	1,083	CY
A. CALCULATED CUT:	1,800	CY
ADDITION SLAB CUT:	36	CY
FOOTING AND UTILITY SPOILS	248	CY
RECYCLE MATERIAL	-	CY
UGS-WQMP	558	CY
TOTAL CUT: (A+B)	2,642	CY
D. CALCULATED FILL:	1,100	CY
E. LIGHT PAVING FILL:	-	CY
F. SUBSIDENCE (LxK)/27=	835	CY
G. SHRINKAGE (M/100)C=	264	CY
H. SITE STRIPPING	334	CY
I. OVEREXCAVATION SHRINKAGE	108	CY
J. TOTAL FILL: (D+E+F+G+H)=	2,642	CY
K. TOTAL (IMPORT) OR EXPORT:	(0)	CY
SITE ADJUSTMENT	(0.00)	

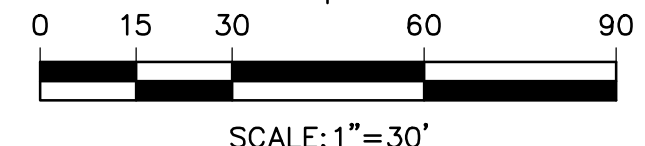
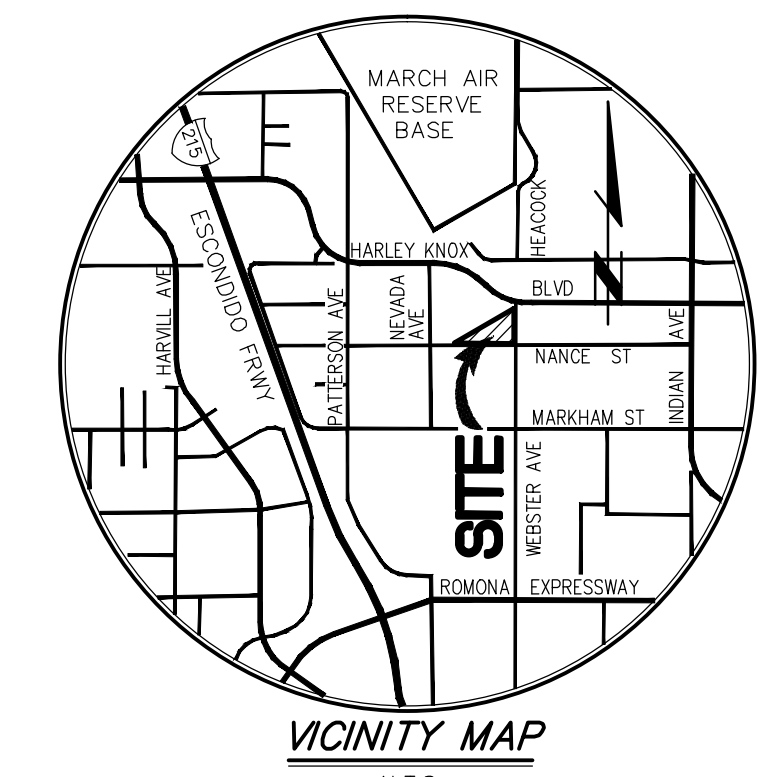

CITY OF PERRIS
PUBLIC WORKS DEPARTMENT
CONCEPTUAL GRADING PLAN
PERRIS TRAILER YARD
NANCE ST. AND WEBSTER AVE.

PREPARED FOR:
LAKE CREEK INDUSTRIAL, LLC
1302 BRITANNY CROSS RD
SANTA ANA, CA 92705
CONTACT: MIKE TONKONOCY

Tai Thienes Engineering, Inc.
CIVIL ENGINEERING - LAND SURVEYING
14144 FORESTONE BOULEVARD
LA BREA, CALIFORNIA 90639
PH: (714) 521-4811 FAX: (714) 521-4773

Designed by	Approved by	Date
Checked by	Public Works Director	R.C.E. XXXXX
Designed by		
Checked by		
Sheet 1 of 4 Sheets		JUN 4108

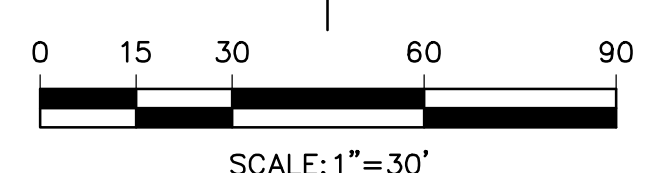
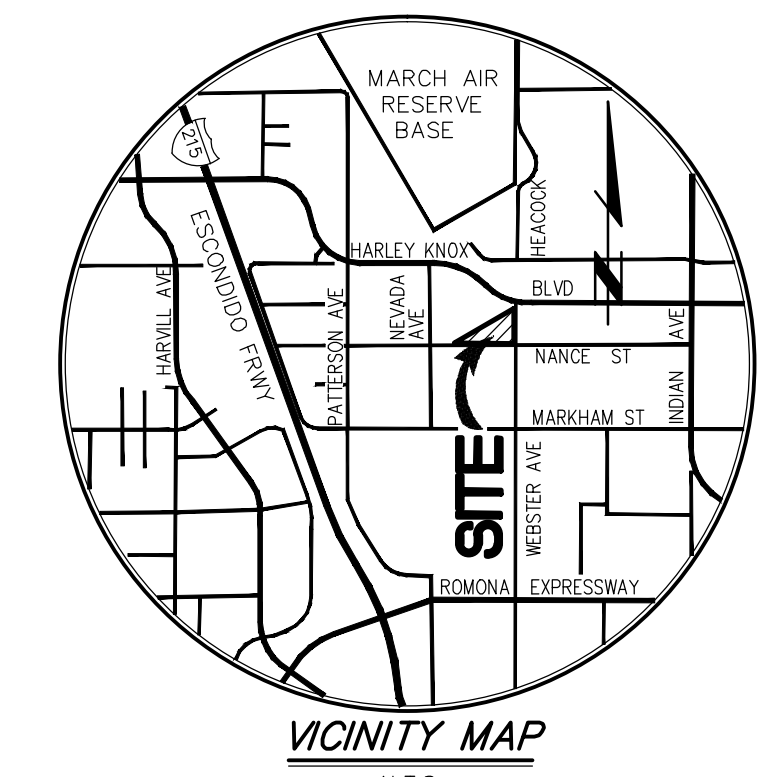
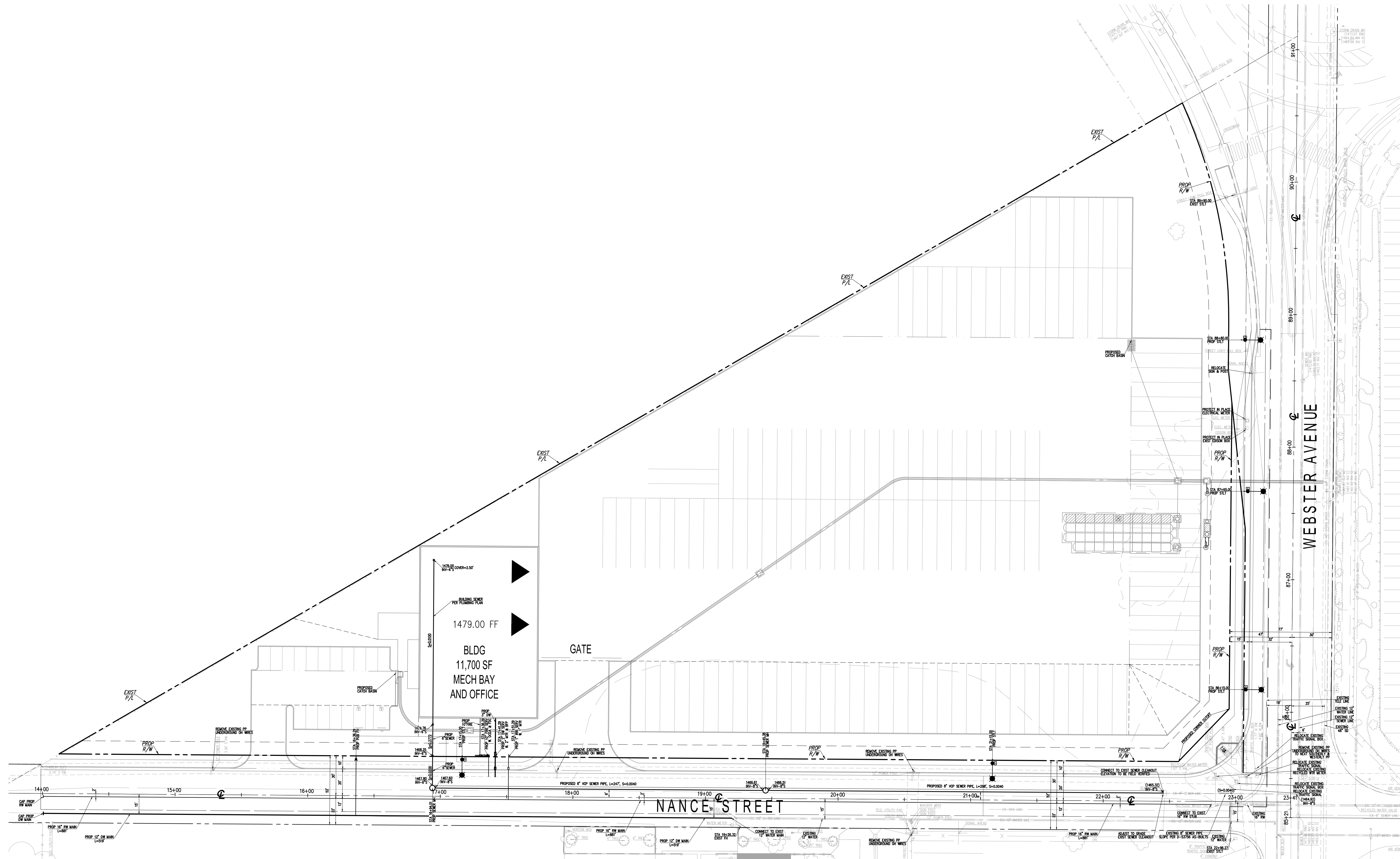

CITY OF PERRIS
PUBLIC WORKS DEPARTMENT
CONCEPTUAL UTILITY PLAN
PERRIS TRAILER YARD
NANCE ST. AND WEBSTER AVE.

PREPARED FOR:
LAKE CREEK INDUSTRIAL, LLC
1302 BRITANNY CROSS RD.
SANTA ANA, CA 92705
CONTACT: MIKE TONKONOCY



Designed by _____	Approved by _____	Date _____
Checked by _____	Public Works Director _____	R.C.E. XXXXX
Designed by _____		
Checked by _____		
Date _____		

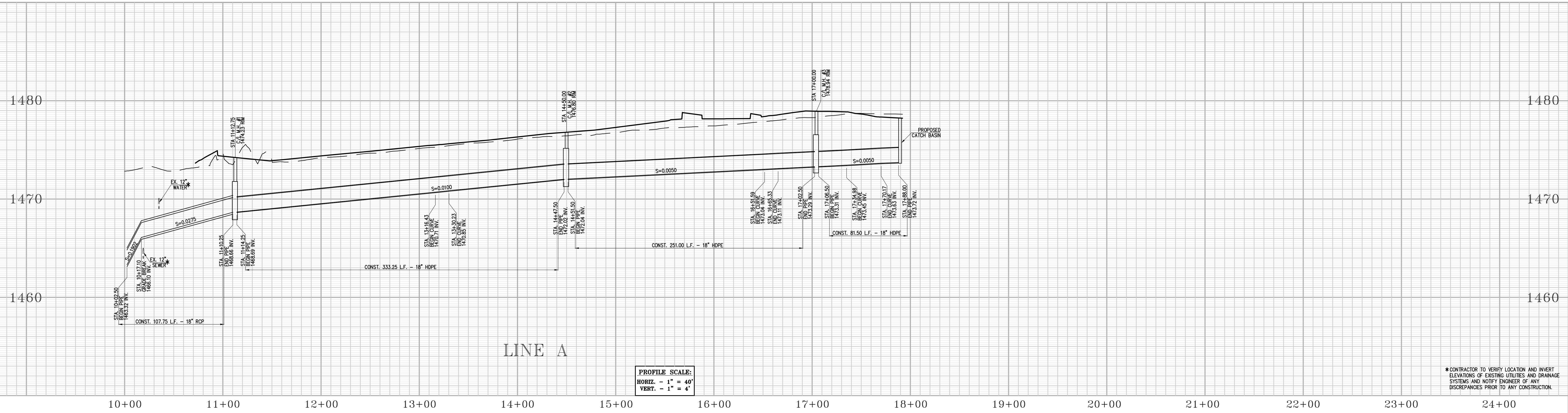

PROFILE SCALE:
 HORIZ. - 1" = 40'
 VERT. - 1" = 4'

* CONTRACTOR TO VERIFY LOCATION AND INVERT ELEVATIONS OF EXISTING UTILITIES AND DRAINAGE SYSTEMS AND NOTIFY ENGINEER OF ANY DISCREPANCIES PRIOR TO ANY CONSTRUCTION.

CITY OF PERRIS
 PUBLIC WORKS DEPARTMENT
CONCEPTUAL STORM DRAIN PLAN
PERRIS TRAILER YARD
NANCE ST. AND WEBSTER AVE.

PREPARED FOR:
 LAKE CREEK INDUSTRIAL, LLC
 1302 BRITANNY CROSS RD.
 SANTA ANA, CA 92705
 CONTACT: MIKE TONKONOCY



Designed by _____	Approved by _____	Date _____
Checked by _____		
Designed by _____	Public Works Director _____	R.C.E. XXXXX
Checked by _____		
Date _____	Sheet 4 of 4	Sheets

JNK: 4108
 Plot Date: 07/20/2022
 Plot Scale: 0.14100-4198141081419820-04-800-PS.dwg

Appendix 3: Soils Information

Geotechnical Study and Other Infiltration Testing Data



**SOUTHERN
CALIFORNIA
GEOTECHNICAL**
A California Corporation

June 8, 2022

Lake Creek Industrial, LLC
1302 Brittany Cross Road
Santa Ana, California 92705

Attention: Mr. Mike Tonkonogy
Manager

Project No.: **22G184-2**

Subject: **Results of Infiltration Testing**
Proposed Maintenance Building and Parking Lot
NWC West Nance Street and North Webster Avenue
Perris, California

Reference: Geotechnical Investigation, Proposed Maintenance Building and Parking Lot, NWC West Nance Street and North Webster Avenue, Perris, California, prepared for Lake Creek Industrial, LLC, by Southern California Geotechnical, Inc. (SCG), SCG Project No. 22G184-1, dated June 8, 2022.

Dear Mr. Tonkonogy:

In accordance with your request, we have conducted infiltration testing at the subject site. We are pleased to present this report summarizing the results of the infiltration testing and our design recommendations.

Scope of Services

The scope of services performed for this project was in general accordance with our Proposal No. 22P221, dated April 21, 2022. The scope of services included site reconnaissance, subsurface exploration, field testing, and engineering analysis to determine the infiltration rates of the on-site soils. The infiltration testing was performed in general accordance with the guidelines published in Riverside County – Low Impact Development BMP Design Handbook – Section 2.3 of Appendix A, prepared for the Riverside County Department of Environmental Health (RCDEH), dated December, 2013.

Site and Project Description

The site is located at the northwest corner of West Nance Street and North Webster Avenue in Perris, California. The site is bounded to the northwest by a vacant lot, to the south by West Nance Street, and to the east by North Webster Avenue. The general location of the site is illustrated on the Site Location Map, included as Plate 1 of this report.

The site consists of seven (7) contiguous parcels, which total 5.61 ± acres in size. The project site is vacant and undeveloped. The ground surface consists of tilled soil with sparse native grass and weed growth.

Detailed topographic information was not available at the time of this report. Based on elevations obtained from Google Earth, and visual observations made at the time of the subsurface investigation, the overall site topography gently slopes downward to the east at a gradient of less than 1 percent.

Proposed Development

Based on the site plan, identified as Scheme 01 dated April 11, 2022, prepared by LHA, the site will be developed with a maintenance building, approximately 7,800 ft² in size located in the western area of the site. It should be noted that the northwestern corner of the building will be constructed in close proximity, 2± feet away, to the property line. The remaining areas of the site will be developed as an asphaltic concrete (AC) or a Portland cement concrete (PCC) parking lot. Landscaped areas and concrete flatwork are also expected to be included throughout the site.

We understand that the proposed development may include on-site stormwater infiltration. Based on our experience with similar projects in the area, the infiltration systems are expected to be several detention basins located in the northern and western areas of the site. The bottoms of the basins are expected to be 8 to 10± feet below the existing site grades.

Concurrent Study

SCG concurrently conducted a geotechnical investigation at the subject site, referenced above. As a part of this study, six (6) borings (identified as Boring Nos. B-1 through B-6) were advanced to depths of 4½ to 20± feet below the existing site grades.

Soils classified as disturbed alluvium were encountered at the ground surface at all of the boring locations. The disturbed alluvium generally consists of medium dense silty sands and clay sands, with occasional dense clayey sands and hard sandy clays, extending to depths of 2½ to 3± feet below the existing site grades. Native younger alluvium was encountered beneath the disturbed alluvium at Boring Nos. B-5 and B-6, extending to depths of 6½ to 10± feet. The younger alluvium generally consists of loose to medium dense clayey sands and silty sands. Native older alluvium was encountered beneath the disturbed alluvium at Boring Nos. B-1 through B-4, and beneath the younger alluvium at Boring No. B-5, extending to at least the maximum depth explored of 20± feet. The older alluvium generally consists of medium dense to dense clayey sands and silty sands and very stiff to hard sandy clays.

Groundwater

Free water was not encountered during the drilling of any of the borings. Based on the moisture content of the recovered soil samples and the lack of free water in the borings, the static groundwater table is at a greater depth than 20± feet below existing site grades.

As a part of our research, we reviewed available groundwater data in order to determine groundwater levels for the site. Water level data was obtained from the California Department of Water Resources Water Data Library website, <https://wdl.water.ca.gov/waterdatalibrary/>. Two (2) monitoring wells on record (identified as Local Well Names: EMWD12471 and EMWD12474) are located within 1,000± feet of the site. Water level readings within these monitoring wells indicate a high groundwater level of 65± feet below the ground surface in March 2022.

Subsurface Exploration

Scope of Exploration

The subsurface exploration conducted for the infiltration testing consisted of four (4) infiltration test borings, advanced to a depth of 10± feet below the existing site grades. The infiltration borings were advanced using a truck-mounted drilling rig, equipped with 8-inch-diameter hollow stem augers and were logged during drilling by a member of our staff. The approximate locations of the infiltration test borings (identified as Infiltration Test Nos. I-1 through I-4) are indicated on the Infiltration Test Location Plan, enclosed as Plate 2 of this report.

Upon the completion of the infiltration borings, the bottom of each test boring was covered with 2± inches of clean ¾-inch gravel. A sufficient length of 3-inch-diameter perforated PVC casing was then placed into each test hole so that the PVC casing extended from the bottom of the test hole to the ground surface. Clean ¾-inch gravel was then installed in the annulus surrounding the PVC casing.

Geotechnical Conditions

Native younger alluvium was encountered at the ground surface at Infiltration Test Nos. I-3 and I-4, extending to depths of 7 to 10± feet below the existing site grades. The younger alluvium generally consists of medium dense silty sands to sandy silts with varying clay content. Native older alluvium was encountered beneath the native younger alluvium at Infiltration Test Nos. I-3 and I-4, and at the ground surface at the remaining infiltration test locations, extending to at least the maximum depth explored of 10± feet. The older alluvium generally consists of medium dense to dense clayey sands, and very stiff to hard sandy clays, with occasional dense silty sands to sandy silts with trace to little clay content. The Boring Logs, which illustrate the conditions encountered at each of the borings, are included with this report.

Infiltration Testing

As previously mentioned, the infiltration testing was performed in general accordance with the Riverside County guidelines: Riverside County – Low Impact Development BMP Design Handbook – Section 2.3 of Appendix A.

Pre-soaking

In accordance with the county infiltration standards all of the infiltration test borings were pre-soaked prior to the infiltration testing. The pre-soaking process consisted of filling the test borings by inverting a full 5-gallon bottle of clear water supported over each hole so that the water level **reaches a level of at least 5 times the hole's radius above the gravel at the bottom of each hole.** The pre-soaking was completed after all of the water had percolated through each test hole or after 15 hours since initiating the pre-soak. Based on the results of the pre-soaking process, 30-minute readings were utilized during all of the infiltration tests.

Infiltration Testing

Following the pre-soaking process of the infiltration test borings, SCG performed the infiltration testing. Each **test hole was filled with water to a depth of at least 5 times the hole's radius above the gravel at the bottom of each test hole.** In accordance with the Riverside County guidelines, **in areas where "non-sandy soils" were encountered at the bottom of the infiltration test borings** (where 6 inches of water did not infiltrate into the surrounding soils in less than 25 minutes for two (2) consecutive readings), readings were taken at 30-minute intervals for a total of 6 hours at the test locations. The water level readings are presented on the spreadsheets enclosed with this report. The infiltration rates for each of the timed intervals are also tabulated on the spreadsheets.

The infiltration rates from the test are tabulated in inches per hour. In accordance with the typically accepted practice, it is recommended that the most conservative reading from the latter part of the infiltration tests be used as the design infiltration rate. The rates are summarized below:

<u>Infiltration Test No.</u>	<u>Depth (feet)</u>	<u>Soil Description</u>	<u>Measured Infiltration Rate (inches/hour)</u>
I-1	10	Gray Brown Clayey fine to medium Sand to fine to medium Sandy Clay, trace to little Silt	0.02
I-2	10	Brown Silty fine to medium Sand to fine to medium Sandy Silt, little to some Clay	0.02
I-3	10	Brown Clayey fine to medium Sand to fine to medium Sandy Clay, trace Silt	0.03
I-4	10	Brown Clayey fine to medium Sand to fine to medium Sandy Clay, trace to little Silt	0.02

Laboratory Testing

Moisture Content

The moisture contents for the recovered soil samples within the borings were determined in accordance with ASTM D-2216 and are expressed as a percentage of the dry weight. These test results are presented on the Boring Logs.

Grain Size Analysis

The grain size distribution of selected soils collected from the bottom of each infiltration test boring have been determined using a range of wire mesh screens. These tests were performed in general accordance with ASTM D-422 and/or ASTM D-1140. The weight of the portion of the sample retained on each screen is recorded and the percentage finer or coarser of the total weight is calculated. The results of these tests are presented on Plates C-1 through C-4 of this report.

Design Recommendations

Four (4) infiltration tests were performed at the subject site. As noted above, the calculated infiltration rates at the infiltration test locations range between 0.02 and 0.03 inches per hour.

The major factors affecting the lack of infiltration at these locations are the presence of alluvial soils consisting of very stiff to hard sandy clays, and medium dense to dense clayey sands and silty sands to sandy silts with varying clay content. **Based on these conditions and the results of infiltration testing, infiltration is not recommended at this site due to the poor draining qualities of the on-site native soils.**

Although infiltration is not considered feasible at the site, the client may desire to use storm water disposal systems that do not rely on infiltration at this site. The design of storm water disposal systems should be performed by the project civil engineer, in accordance with the City of Perris and/or County of Riverside guidelines. It is recommended any such systems be designed and constructed to facilitate removal of silt and clay, or other deleterious materials from any water that may enter the system. The presence of such materials would decrease the flow rates through the system. It should be noted that the recommended infiltration rates are based on infiltration testing at four (4) discrete locations and that the overall infiltration rates of the proposed infiltration systems could vary considerably.

General Comments

This report has been prepared as an instrument of service for use by the client in order to aid in the evaluation of this property and to assist the architects and engineers in the design and preparation of the project plans and specifications. This report may be provided to the contractor(s) and other design consultants to disclose information relative to the project. However, this report is not intended to be utilized as a specification in and of itself, without appropriate interpretation by the project architect, structural engineer, and/or civil engineer. The design of the proposed storm water infiltration system is the responsibility of the civil engineer. The role of the geotechnical engineer is limited to determination of infiltration rate only. By using the design infiltration rate contained herein, the civil engineer agrees to indemnify, defend, and hold harmless the geotechnical engineer for all aspects of the design and performance of the proposed storm water infiltration system. The reproduction and distribution of this report must be authorized by the client and Southern California Geotechnical, Inc. Furthermore, any reliance **on this report by an unauthorized third party is at such party's sole risk, and we accept no responsibility for damage or loss which may occur.**

The analysis of this site was based on a subsurface profile interpolated from limited discrete soil samples. While the materials encountered in the project area are considered to be representative of the total area, some variations should be expected between boring locations and testing depths. If the conditions encountered during construction vary significantly from those detailed herein, we should be contacted immediately to determine if the conditions alter the recommendations contained herein.

This report has been based on assumed or provided characteristics of the proposed development. It is recommended that the owner, client, architect, structural engineer, and civil engineer carefully review these assumptions to ensure that they are consistent with the characteristics of the proposed development. If discrepancies exist, they should be brought to our attention to verify that they do not affect the conclusions and recommendations contained herein. We also recommend that the project plans and specifications be submitted to our office for review to verify that our recommendations have been correctly interpreted. The analysis, conclusions, and

recommendations contained within this report have been promulgated in accordance with generally accepted professional geotechnical engineering practice. No other warranty is implied or expressed.

Closure

We sincerely appreciate the opportunity to be of service on this project. We look forward to providing additional consulting services during the course of the project. If we may be of further assistance in any manner, please contact our office.

Respectfully Submitted,

SOUTHERN CALIFORNIA GEOTECHNICAL, INC.



Joseph Lozano Leon
Staff Engineer



Robert G. Trazo, GE 2655
Principal Engineer



Distribution: (1) Addressee

Enclosures: Plate 1 - Site Location Map
Plate 2 - Infiltration Test Location Plan
Boring Log Legend and Logs (6 pages)
Infiltration Test Results Spreadsheets (4 pages)
Grain Size Distribution Graphs (4 pages)

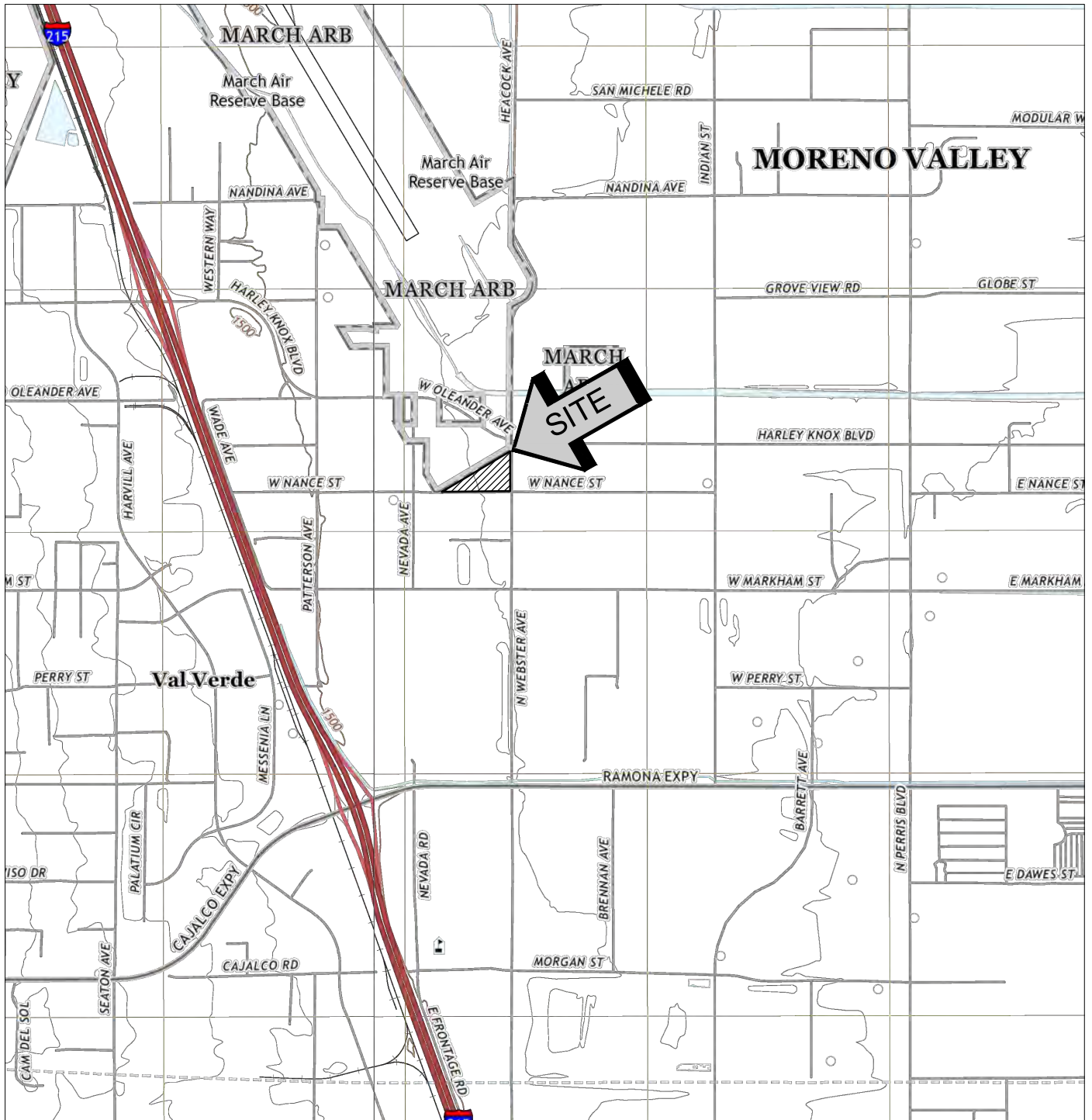



SOURCE: USGS TOPOGRAPHIC MAPS OF THE STEELE PEAK QUADRANGLE AND THE PERRIS QUADRANGLE, RIVERSIDE COUNTY, CALIFORNIA, 2021.



SITE LOCATION MAP	
PROPOSED MAINTENANCE BUILDING AND PARKING LOT	
PERRIS, CALIFORNIA	
SCALE: 1" = 2000'	 SOUTHERN CALIFORNIA GEOTECHNICAL
DRAWN: JLL	
CHKD: RGT	
SCG PROJECT 22G184-2	
PLATE 1	









GEOTECHNICAL LEGEND

-  APPROXIMATE INFILTRATION TEST LOCATION
-  APPROXIMATE BORING LOCATION FROM CONCURRENT STUDY (SCG PROJECT NO. 22G184-1)

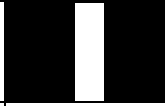
NOTE: SITE PLAN PROVIDED BY THE CLIENT.

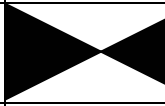
INFILTRATION TEST LOCATION PLAN	
PROPOSED MAINTENANCE BUILDING AND PARKING LOT	
PERRIS, CALIFORNIA	
SCALE: 1" = 80'	 SOUTHERN CALIFORNIA GEOTECHNICAL
DRAWN: JLL	
CHKD: RGT	
SCG PROJECT 22G184-2	
PLATE 2	

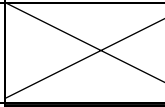
BORING LOG LEGEND

SAMPLE TYPE	GRAPHICAL SYMBOL	SAMPLE DESCRIPTION
AUGER		SAMPLE COLLECTED FROM AUGER CUTTINGS, NO FIELD MEASUREMENT OF SOIL STRENGTH. (DISTURBED)
CORE		ROCK CORE SAMPLE: TYPICALLY TAKEN WITH A DIAMOND-TIPPED CORE BARREL. TYPICALLY USED ONLY IN HIGHLY CONSOLIDATED BEDROCK.
GRAB		SOIL SAMPLE TAKEN WITH NO SPECIALIZED EQUIPMENT, SUCH AS FROM A STOCKPILE OR THE GROUND SURFACE. (DISTURBED)
CS		CALIFORNIA SAMPLER: 2-1/2 INCH I.D. SPLIT BARREL SAMPLER, LINED WITH 1-INCH HIGH BRASS RINGS. DRIVEN WITH SPT HAMMER. (RELATIVELY UNDISTURBED)
NSR		NO RECOVERY: THE SAMPLING ATTEMPT DID NOT RESULT IN RECOVERY OF ANY SIGNIFICANT SOIL OR ROCK MATERIAL.
SPT		STANDARD PENETRATION TEST: SAMPLER IS A 1.4 INCH INSIDE DIAMETER SPLIT BARREL, DRIVEN 18 INCHES WITH THE SPT HAMMER. (DISTURBED)
SH		SHELBY TUBE: TAKEN WITH A THIN WALL SAMPLE TUBE, PUSHED INTO THE SOIL AND THEN EXTRACTED. (UNDISTURBED)
VANE		VANE SHEAR TEST: SOIL STRENGTH OBTAINED USING A 4 BLADED SHEAR DEVICE. TYPICALLY USED IN SOFT CLAYS-NO SAMPLE RECOVERED.

COLUMN DESCRIPTIONS

DEPTH:

Distance in feet below the ground surface.

SAMPLE:

Sample Type as depicted above.

BLOW COUNT:

Number of blows required to advance the sampler 12 inches using a 140 lb hammer with a 30-inch drop. 50/3" indicates penetration refusal (>50 blows) at 3 inches. WH indicates that the weight of the hammer was sufficient to push the sampler 6 inches or more.

POCKET PEN.:

Approximate shear strength of a cohesive soil sample as measured by pocket penetrometer.

GRAPHIC LOG:

Graphic Soil Symbol as depicted on the following page.

DRY DENSITY:

Dry density of an undisturbed or relatively undisturbed sample in lbs/ft³.

MOISTURE CONTENT:

Moisture content of a soil sample, expressed as a percentage of the dry weight.

LIQUID LIMIT:

The moisture content above which a soil behaves as a liquid.

PLASTIC LIMIT:

The moisture content above which a soil behaves as a plastic.

PASSING #200 SIEVE:

The percentage of the sample finer than the #200 standard sieve.

UNCONFINED SHEAR:

The shear strength of a cohesive soil sample, as measured in the unconfined state.

SOIL CLASSIFICATION CHART

MAJOR DIVISIONS			SYMBOLS		TYPICAL DESCRIPTIONS	
			GRAPH	LETTER		
<p>COARSE GRAINED SOILS</p> <p>MORE THAN 50% OF MATERIAL IS LARGER THAN NO. 200 SIEVE SIZE</p>	<p>GRAVEL AND GRAVELLY SOILS</p>	<p>CLEAN GRAVELS</p> <p>(LITTLE OR NO FINES)</p>		GW	WELL-GRADED GRAVELS, GRAVEL - SAND MIXTURES, LITTLE OR NO FINES	
		<p>MORE THAN 50% OF COARSE FRACTION RETAINED ON NO. 4 SIEVE</p>	<p>GRAVELS WITH FINES</p> <p>(APPRECIABLE AMOUNT OF FINES)</p>		GP	POORLY-GRADED GRAVELS, GRAVEL - SAND MIXTURES, LITTLE OR NO FINES
			<p>GRAVELS WITH FINES</p> <p>(APPRECIABLE AMOUNT OF FINES)</p>		GM	SILTY GRAVELS, GRAVEL - SAND - SILT MIXTURES
		<p>MORE THAN 50% OF COARSE FRACTION PASSING ON NO. 4 SIEVE</p>	<p>CLEAN SANDS</p> <p>(LITTLE OR NO FINES)</p>		SW	WELL-GRADED SANDS, GRAVELLY SANDS, LITTLE OR NO FINES
	<p>MORE THAN 50% OF COARSE FRACTION PASSING ON NO. 4 SIEVE</p>		<p>SANDS WITH FINES</p> <p>(APPRECIABLE AMOUNT OF FINES)</p>		SP	POORLY-GRADED SANDS, GRAVELLY SAND, LITTLE OR NO FINES
		<p>SANDS WITH FINES</p> <p>(APPRECIABLE AMOUNT OF FINES)</p>		SM	SILTY SANDS, SAND - SILT MIXTURES	
	<p>FINE GRAINED SOILS</p> <p>MORE THAN 50% OF MATERIAL IS SMALLER THAN NO. 200 SIEVE SIZE</p>	<p>SILTS AND CLAYS</p> <p>LIQUID LIMIT LESS THAN 50</p>		ML	INORGANIC SILTS AND VERY FINE SANDS, ROCK FLOUR, SILTY OR CLAYEY FINE SANDS OR CLAYEY SILTS WITH SLIGHT PLASTICITY	
				CL	INORGANIC CLAYS OF LOW TO MEDIUM PLASTICITY, GRAVELLY CLAYS, SANDY CLAYS, SILTY CLAYS, LEAN CLAYS	
				OL	ORGANIC SILTS AND ORGANIC SILTY CLAYS OF LOW PLASTICITY	
		<p>SILTS AND CLAYS</p> <p>LIQUID LIMIT GREATER THAN 50</p>		MH	INORGANIC SILTS, MICACEOUS OR DIATOMACEOUS FINE SAND OR SILTY SOILS	
			CH	INORGANIC CLAYS OF HIGH PLASTICITY		
			OH	ORGANIC CLAYS OF MEDIUM TO HIGH PLASTICITY, ORGANIC SILTS		
<p>HIGHLY ORGANIC SOILS</p>				PT	PEAT, HUMUS, SWAMP SOILS WITH HIGH ORGANIC CONTENTS	

NOTE: DUAL SYMBOLS ARE USED TO INDICATE BORDERLINE SOIL CLASSIFICATIONS



JOB NO.: 22G184-2	DRILLING DATE: 5/6/22	WATER DEPTH: Dry
PROJECT: Prop. Maintenance Bldg. & Parking Lot	DRILLING METHOD: Hollow Stem Auger	CAVE DEPTH: ---
LOCATION: Perris, California	LOGGED BY: Daryl Kas	READING TAKEN: At Completion

FIELD RESULTS				GRAPHIC LOG	DESCRIPTION	LABORATORY RESULTS						COMMENTS
DEPTH (FEET)	SAMPLE	BLOW COUNT	POCKET PEN. (TSF)			DRY DENSITY (PCF)	MOISTURE CONTENT (%)	LIQUID LIMIT	PLASTIC LIMIT	PASSING #200 SIEVE (%)	ORGANIC CONTENT (%)	
SURFACE ELEVATION: --- MSL												
5		22		OLDER ALLUVIUM: Brown Clayey fine Sand, little Silt, trace medium Sand, cemented, medium dense-moist		9						
10		30	4.5	Gray Brown Clayey fine to medium Sand to fine to medium Sandy Clay, trace to little Silt, slightly cemented, dense to hard-damp		8			49			
Boring Terminated at 10'												

TBL 22G184-2.GPJ_SOCALGEO.GDT 6/8/22





JOB NO.: 22G184-2	DRILLING DATE: 5/6/22	WATER DEPTH: Dry
PROJECT: Prop. Maintenance Bldg. & Parking Lot	DRILLING METHOD: Hollow Stem Auger	CAVE DEPTH: ---
LOCATION: Perris, California	LOGGED BY: Daryl Kas	READING TAKEN: At Completion

FIELD RESULTS				GRAPHIC LOG	DESCRIPTION	LABORATORY RESULTS						COMMENTS
DEPTH (FEET)	SAMPLE	BLOW COUNT	POCKET PEN. (TSF)			DRY DENSITY (PCF)	MOISTURE CONTENT (%)	LIQUID LIMIT	PLASTIC LIMIT	PASSING #200 SIEVE (%)	ORGANIC CONTENT (%)	
SURFACE ELEVATION: --- MSL												
5	X	17	4.5		OLDER ALLUVIUM: Brown fine Sandy Clay, trace Silt, trace medium Sand, very stiff-moist		13					
10	X	40			Brown Silty fine to medium Sand to fine to medium Sandy Silt, little to some Clay, dense-moist		11		57			
					Boring Terminated at 10'							

TBL 22G184-2.GPJ_SOCALGEO.GDT 6/8/22

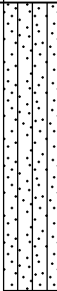

JOB NO.: 22G184-2	DRILLING DATE: 5/6/22	WATER DEPTH: Dry
PROJECT: Prop. Maintenance Bldg. & Parking Lot	DRILLING METHOD: Hollow Stem Auger	CAVE DEPTH: ---
LOCATION: Perris, California	LOGGED BY: Daryl Kas	READING TAKEN: At Completion

FIELD RESULTS				GRAPHIC LOG	DESCRIPTION	LABORATORY RESULTS						COMMENTS
DEPTH (FEET)	SAMPLE	BLOW COUNT	POCKET PEN. (TSF)			DRY DENSITY (PCF)	MOISTURE CONTENT (%)	LIQUID LIMIT	PLASTIC LIMIT	PASSING #200 SIEVE (%)	ORGANIC CONTENT (%)	
5		18			SURFACE ELEVATION: --- MSL YOUNGER ALLUVIUM: Brown Silty fine Sand to fine Sandy Silt, trace Clay, trace Calcareous nodules, medium dense-damp to moist		9					
10		34	4.0		OLDER ALLUVIUM: Brown Clayey fine to medium Sand to fine to medium Sandy Clay, trace Silt, dense to hard-moist		10		48			
					Boring Terminated at 10'							

TBL 22G184-2.GPJ_SOCALGEO.GDT 6/8/22



JOB NO.: 22G184-2	DRILLING DATE: 5/6/22	WATER DEPTH: Dry
PROJECT: Prop. Maintenance Bldg. & Parking Lot	DRILLING METHOD: Hollow Stem Auger	CAVE DEPTH: ---
LOCATION: Perris, California	LOGGED BY: Daryl Kas	READING TAKEN: At Completion

FIELD RESULTS				GRAPHIC LOG	DESCRIPTION	LABORATORY RESULTS						COMMENTS
DEPTH (FEET)	SAMPLE	BLOW COUNT	POCKET PEN. (TSF)			DRY DENSITY (PCF)	MOISTURE CONTENT (%)	LIQUID LIMIT	PLASTIC LIMIT	PASSING #200 SIEVE (%)	ORGANIC CONTENT (%)	
SURFACE ELEVATION: --- MSL												
5		10			YOUNGER ALLUVIUM: Brown Silty fine Sand to fine Sandy Silt, trace medium Sand, medium dense-damp		8					
10		20	4.5		Brown Clayey fine to medium Sand to fine to medium Sandy Clay, trace to little Silt, medium dense to very stiff-moist		11		53			
					Boring Terminated at 10'							

TBL 22G184-2.GPJ_SOCALGEO.GDT 6/8/22

INFILTRATION CALCULATIONS

Project Name	Proposed Maintenance Building and Parking Lot
Project Location	Perris, California
Project Number	22G184-2
Engineer	Michelle Esparza

Test Hole Radius	4 (in)
Test Depth	10.00 (ft)

Infiltration Test Hole I-1

Soil Criteria Test							
Interval Number		Time	Time Interval (min)	Water Depth (ft)	Change in Water Level (in)	Did 6 inches of water seep away in less than 25 minutes?	Sandy Soils or Non-Sandy Soils?
1	Initial	7:30 AM	25.00	7.88	0.24	NO	NON-SANDY SOILS
	Final	7:55 AM		7.90			
2	Initial	7:55 AM	25.00	7.88	0.12	NO	NON-SANDY SOILS
	Final	8:20 AM		7.89			

Test Data							
Interval Number		Time	Time Interval (min)	Water Depth (ft)	Change in Water Level (ft)	Average Head Height (ft)	Infiltration Rate Q (in/hr)
1	Initial	8:20 AM	30.00	7.88	0.01	2.12	0.02
	Final	8:50 AM		7.89			
2	Initial	8:50 AM	30.00	7.88	0.01	2.12	0.02
	Final	9:20 AM		7.89			
3	Initial	9:20 AM	30.00	7.88	0.01	2.12	0.02
	Final	9:50 AM		7.89			
4	Initial	9:50 AM	30.00	7.88	0.01	2.12	0.02
	Final	10:20 AM		7.89			
5	Initial	10:20 AM	30.00	7.88	0.01	2.12	0.02
	Final	10:50 AM		7.89			
6	Initial	10:50 AM	30.00	7.88	0.01	2.12	0.02
	Final	11:20 AM		7.89			
7	Initial	11:20 AM	30.00	7.88	0.01	2.12	0.02
	Final	11:50 AM		7.89			
8	Initial	11:50 AM	30.00	7.88	0.01	2.12	0.02
	Final	12:20 PM		7.89			
9	Initial	12:20 PM	30.00	7.88	0.01	2.12	0.02
	Final	12:50 PM		7.89			
10	Initial	12:50 PM	30.00	7.88	0.01	2.12	0.02
	Final	1:20 PM		7.89			
11	Initial	1:20 PM	30.00	7.88	0.01	2.12	0.02
	Final	1:50 PM		7.89			
12	Initial	1:50 PM	30.00	7.88	0.01	2.12	0.02
	Final	2:20 PM		7.89			

Per County Standards, Infiltration Rate calculated as follows:

$$Q = \frac{\Delta H(60r)}{\Delta t(r + 2H_{avg})}$$

- Where: Q = Infiltration Rate (in inches per hour)
- ΔH = Change in Height (Water Level) over the time interval
- r = Test Hole (Borehole) Radius
- Δt = Time Interval
- H_{avg} = Average Head Height over the time interval

INFILTRATION CALCULATIONS

Project Name	Proposed Maintenance Building and Parking Lot
Project Location	Perris, California
Project Number	22G184-2
Engineer	Michelle Esparza

Test Hole Radius	4 (in)
Test Depth	10.00 (ft)

Infiltration Test Hole	I-2
------------------------	-----

Soil Criteria Test							
Interval Number		Time	Time Interval (min)	Water Depth (ft)	Change in Water Level (in)	Did 6 inches of water seep away in less than 25 minutes?	Sandy Soils or Non-Sandy Soils?
1	Initial	7:35 AM	25.00	7.96	0.24	NO	NON-SANDY SOILS
	Final	8:00 AM		7.98			
2	Initial	8:00 AM	25.00	7.96	0.12	NO	NON-SANDY SOILS
	Final	8:25 AM		7.97			

Test Data							
Interval Number		Time	Time Interval (min)	Water Depth (ft)	Change in Water Level (ft)	Average Head Height (ft)	Infiltration Rate Q (in/hr)
1	Initial	8:25 AM	30.00	7.96	0.01	2.04	0.02
	Final	8:55 AM		7.97			
2	Initial	8:55 AM	30.00	7.96	0.01	2.04	0.02
	Final	9:25 AM		7.97			
3	Initial	9:25 AM	30.00	7.96	0.01	2.04	0.02
	Final	9:55 AM		7.97			
4	Initial	9:55 AM	30.00	7.96	0.01	2.04	0.02
	Final	10:25 AM		7.97			
5	Initial	10:25 AM	30.00	7.96	0.01	2.04	0.02
	Final	10:55 AM		7.97			
6	Initial	10:55 AM	30.00	7.96	0.01	2.04	0.02
	Final	11:25 AM		7.97			
7	Initial	11:25 AM	30.00	7.96	0.01	2.04	0.02
	Final	11:55 AM		7.97			
8	Initial	11:55 AM	30.00	7.96	0.01	2.04	0.02
	Final	12:25 PM		7.97			
9	Initial	12:25 PM	30.00	7.96	0.01	2.04	0.02
	Final	12:55 PM		7.97			
10	Initial	12:55 PM	30.00	7.96	0.01	2.04	0.02
	Final	1:25 PM		7.97			
11	Initial	1:25 PM	30.00	7.96	0.01	2.04	0.02
	Final	1:55 PM		7.97			
12	Initial	1:55 PM	30.00	7.96	0.01	2.04	0.02
	Final	2:25 PM		7.97			

Per County Standards, Infiltration Rate calculated as follows:

$$Q = \frac{\Delta H(60r)}{\Delta t(r + 2H_{avg})}$$

- Where: Q = Infiltration Rate (in inches per hour)
- ΔH = Change in Height (Water Level) over the time interval
- r = Test Hole (Borehole) Radius
- Δt = Time Interval
- H_{avg} = Average Head Height over the time interval

INFILTRATION CALCULATIONS

Project Name	Proposed Maintenance Building and Parking Lot
Project Location	Perris, California
Project Number	22G184-2
Engineer	Michelle Esparza

Test Hole Radius	4 (in)
Test Depth	10.00 (ft)

Infiltration Test Hole I-3

Soil Criteria Test							
Interval Number		Time	Time Interval (min)	Water Depth (ft)	Change in Water Level (in)	Did 6 inches of water seep away in less than 25 minutes?	Sandy Soils or Non-Sandy Soils?
1	Initial	7:40 AM	25.00	7.83	0.24	NO	NON-SANDY SOILS
	Final	8:05 AM		7.85			
2	Initial	8:05 AM	25.00	7.83	0.24	NO	NON-SANDY SOILS
	Final	8:30 AM		7.85			

Test Data							
Interval Number		Time	Time Interval (min)	Water Depth (ft)	Change in Water Level (ft)	Average Head Height (ft)	Infiltration Rate Q (in/hr)
1	Initial	8:30 AM	30.00	7.83	0.02	2.16	0.03
	Final	9:00 AM		7.85			
2	Initial	9:00 AM	30.00	7.83	0.02	2.16	0.03
	Final	9:30 AM		7.85			
3	Initial	9:30 AM	30.00	7.83	0.02	2.16	0.03
	Final	10:00 AM		7.85			
4	Initial	10:00 AM	30.00	7.83	0.02	2.16	0.03
	Final	10:30 AM		7.85			
5	Initial	10:30 AM	30.00	7.83	0.02	2.16	0.03
	Final	11:00 AM		7.85			
6	Initial	11:00 AM	30.00	7.83	0.02	2.16	0.03
	Final	11:30 AM		7.85			
7	Initial	11:30 AM	30.00	7.83	0.02	2.16	0.03
	Final	12:00 PM		7.85			
8	Initial	12:00 PM	30.00	7.83	0.02	2.16	0.03
	Final	12:30 PM		7.85			
9	Initial	12:30 PM	30.00	7.83	0.02	2.16	0.03
	Final	1:00 PM		7.85			
10	Initial	1:00 PM	30.00	7.83	0.02	2.16	0.03
	Final	1:30 PM		7.85			
11	Initial	1:30 PM	30.00	7.83	0.02	2.16	0.03
	Final	2:00 PM		7.85			
12	Initial	2:00 PM	30.00	7.83	0.02	2.16	0.03
	Final	2:30 PM		7.85			

Per County Standards, Infiltration Rate calculated as follows:

$$Q = \frac{\Delta H(60r)}{\Delta t(r + 2H_{avg})}$$

- Where:
- Q = Infiltration Rate (in inches per hour)
 - ΔH = Change in Height (Water Level) over the time interval
 - r = Test Hole (Borehole) Radius
 - Δt = Time Interval
 - H_{avg} = Average Head Height over the time interval

INFILTRATION CALCULATIONS

Project Name	Proposed Maintenance Building and Parking Lot
Project Location	Perris, California
Project Number	22G184-2
Engineer	Michelle Esparza

Test Hole Radius	4 (in)
Test Depth	10.00 (ft)

Infiltration Test Hole I-4

Soil Criteria Test							
Interval Number		Time	Time Interval (min)	Water Depth (ft)	Change in Water Level (in)	Did 6 inches of water seep away in less than 25 minutes?	Sandy Soils or Non-Sandy Soils?
1	Initial	7:45 AM	25.00	8.04	0.12	NO	NON-SANDY SOILS
	Final	8:10 AM		8.05			
2	Initial	8:10 AM	25.00	8.04	0.12	NO	NON-SANDY SOILS
	Final	8:35 AM		8.05			

Test Data							
Interval Number		Time	Time Interval (min)	Water Depth (ft)	Change in Water Level (ft)	Average Head Height (ft)	Infiltration Rate Q (in/hr)
1	Initial	8:35 AM	30.00	8.04	0.01	1.96	0.02
	Final	9:05 AM		8.05			
2	Initial	9:05 AM	30.00	8.04	0.01	1.96	0.02
	Final	9:35 AM		8.05			
3	Initial	9:35 AM	30.00	8.04	0.01	1.96	0.02
	Final	10:05 AM		8.05			
4	Initial	10:05 AM	30.00	8.04	0.01	1.96	0.02
	Final	10:35 AM		8.05			
5	Initial	10:35 AM	30.00	8.04	0.01	1.96	0.02
	Final	11:05 AM		8.05			
6	Initial	11:05 AM	30.00	8.04	0.01	1.96	0.02
	Final	11:35 AM		8.05			
7	Initial	11:35 AM	30.00	8.04	0.01	1.96	0.02
	Final	12:05 PM		8.05			
8	Initial	12:05 PM	30.00	8.04	0.01	1.96	0.02
	Final	12:35 PM		8.05			
9	Initial	12:35 PM	30.00	8.04	0.01	1.96	0.02
	Final	1:05 PM		8.05			
10	Initial	1:05 PM	30.00	8.04	0.01	1.96	0.02
	Final	1:35 PM		8.05			
11	Initial	1:35 PM	30.00	8.04	0.01	1.96	0.02
	Final	2:05 PM		8.05			
12	Initial	2:05 PM	30.00	8.04	0.01	1.96	0.02
	Final	2:35 PM		8.05			

Per County Standards, Infiltration Rate calculated as follows:

$$Q = \frac{\Delta H(60r)}{\Delta t(r + 2H_{avg})}$$

- Where:
- Q = Infiltration Rate (in inches per hour)
 - ΔH = Change in Height (Water Level) over the time interval
 - r = Test Hole (Borehole) Radius
 - Δt = Time Interval
 - H_{avg} = Average Head Height over the time interval

Grain Size Distribution

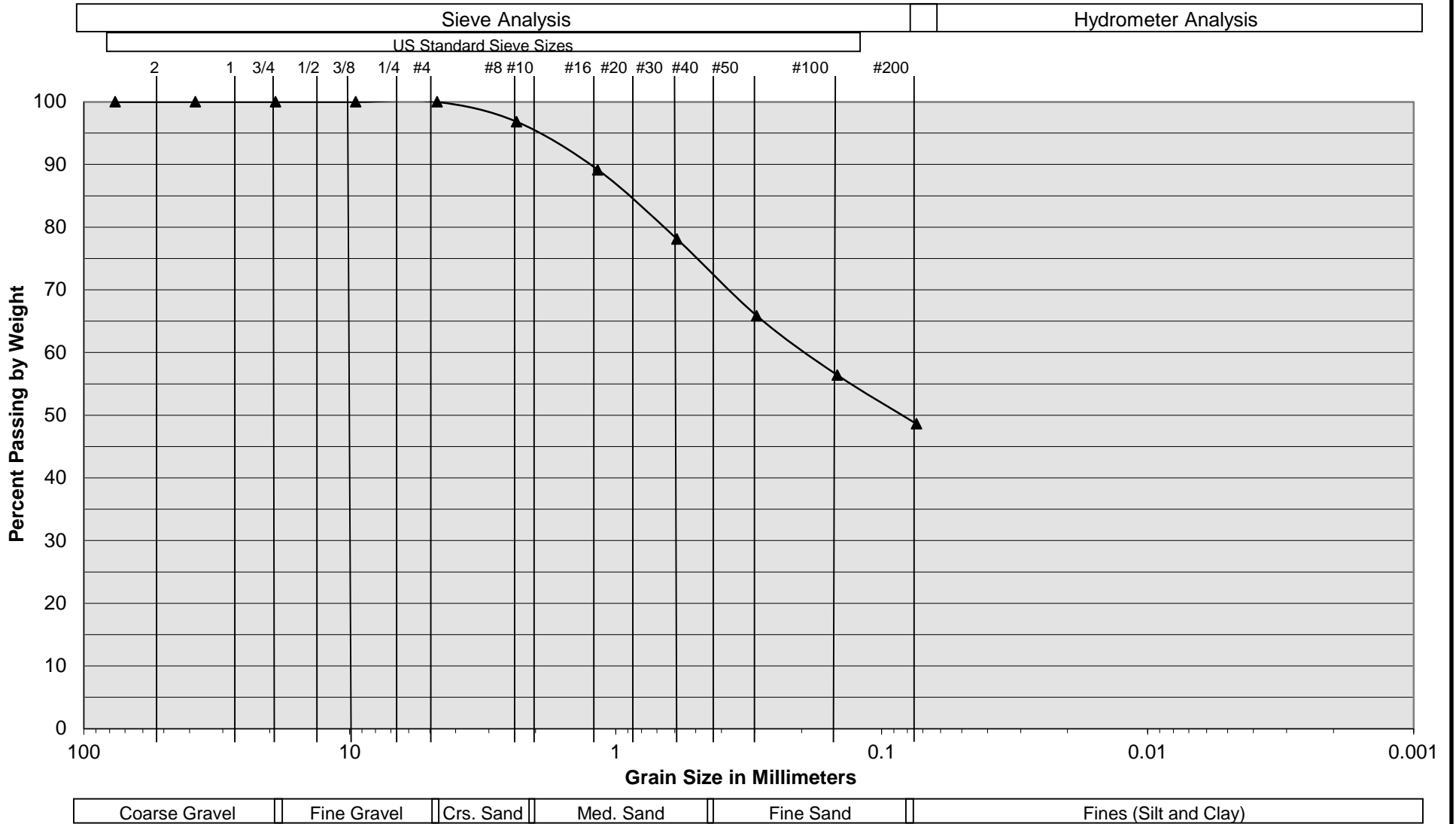

Sample Description	I-1 @ 8½'
Soil Classification	Gray Brown Clayey fine to medium Sand to fine to medium Sandy Clay, trace coarse Sand, trace to little Silt

Proposed Maintenance Building and Parking Lot
 Perris, California
 Project No. 22G184-2
PLATE C- 1



SOUTHERN CALIFORNIA GEOTECHNICAL
A California Corporation

Grain Size Distribution

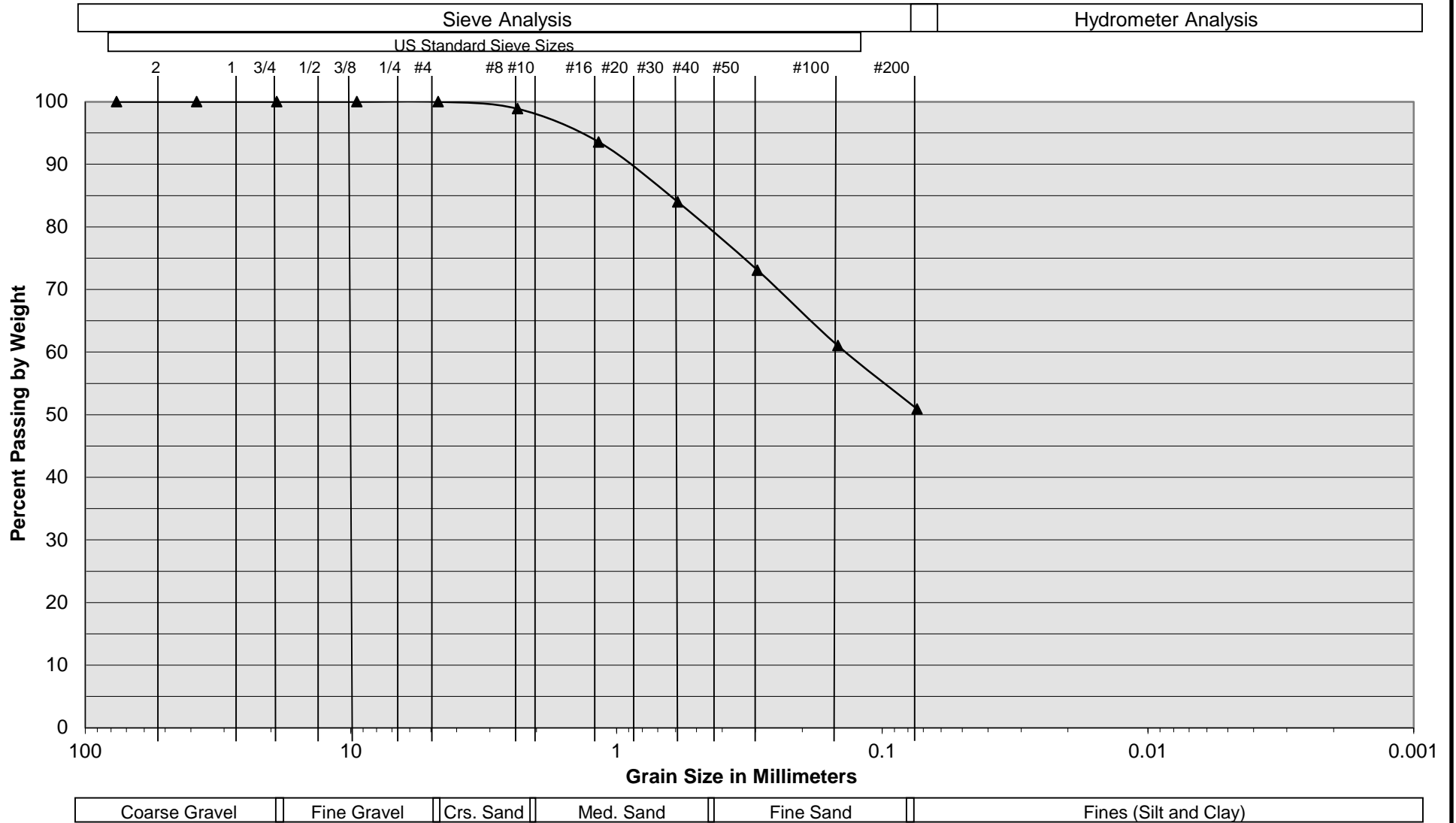

Sample Description	I-2 @ 8½'
Soil Classification	Brown Silty fine to medium Sand to fine to medium Sandy Silt, little to some Clay

Proposed Maintenance Building and Parking Lot
 Perris, California
 Project No. 22G184-2
PLATE C- 2

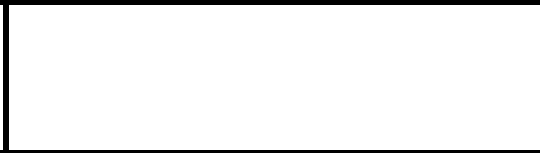

SOUTHERN CALIFORNIA GEOTECHNICAL
A California Corporation

Grain Size Distribution

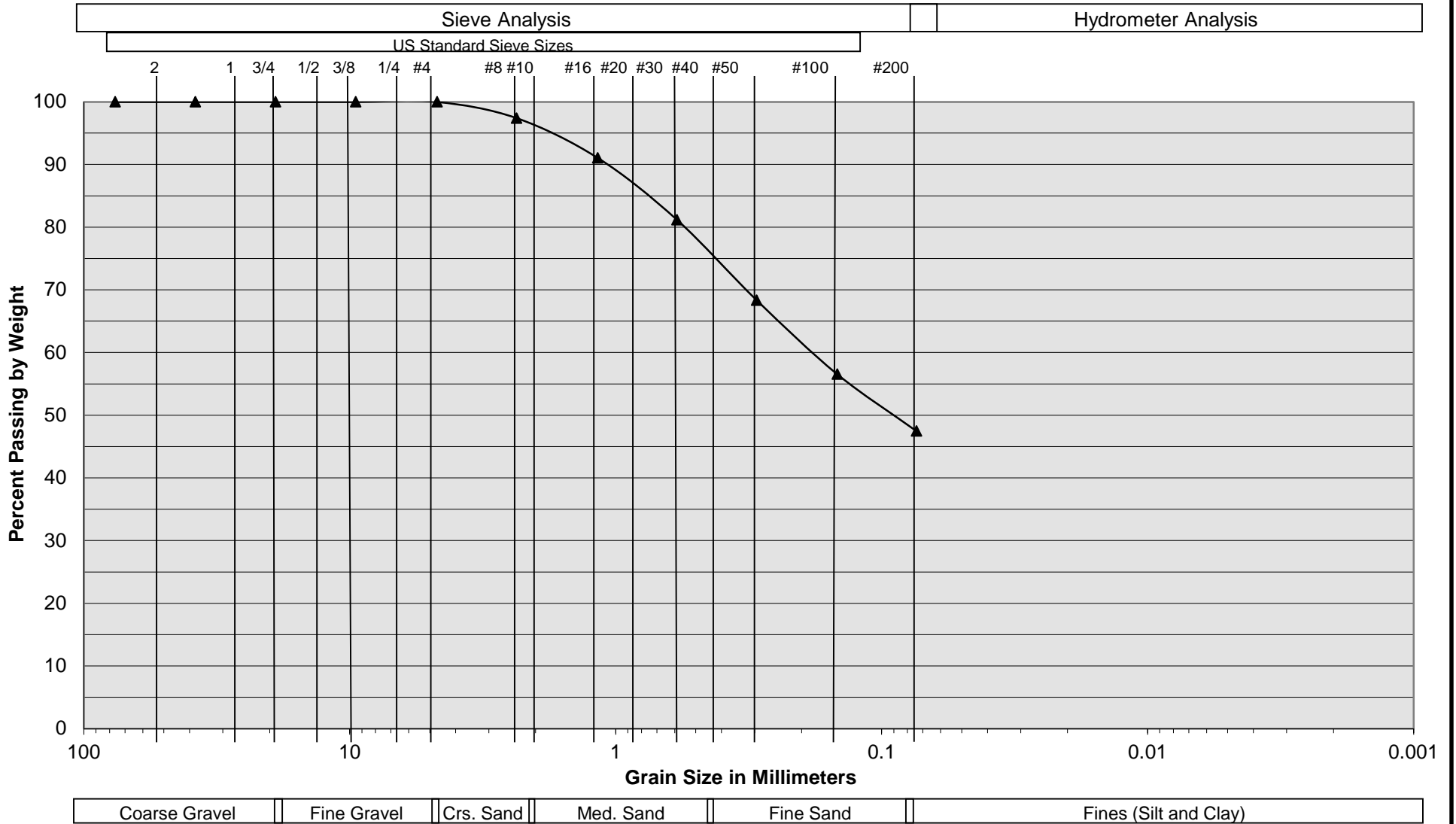

Sample Description	I-3 @ 8½'
Soil Classification	Brown Clayey fine to medium Sand to fine to medium Sandy Clay, trace coarse Sand, trace Silt

Proposed Maintenance Building and Parking Lot
 Perris, California
 Project No. 22G184-2
PLATE C- 3



SOUTHERN CALIFORNIA GEOTECHNICAL
A California Corporation

Grain Size Distribution

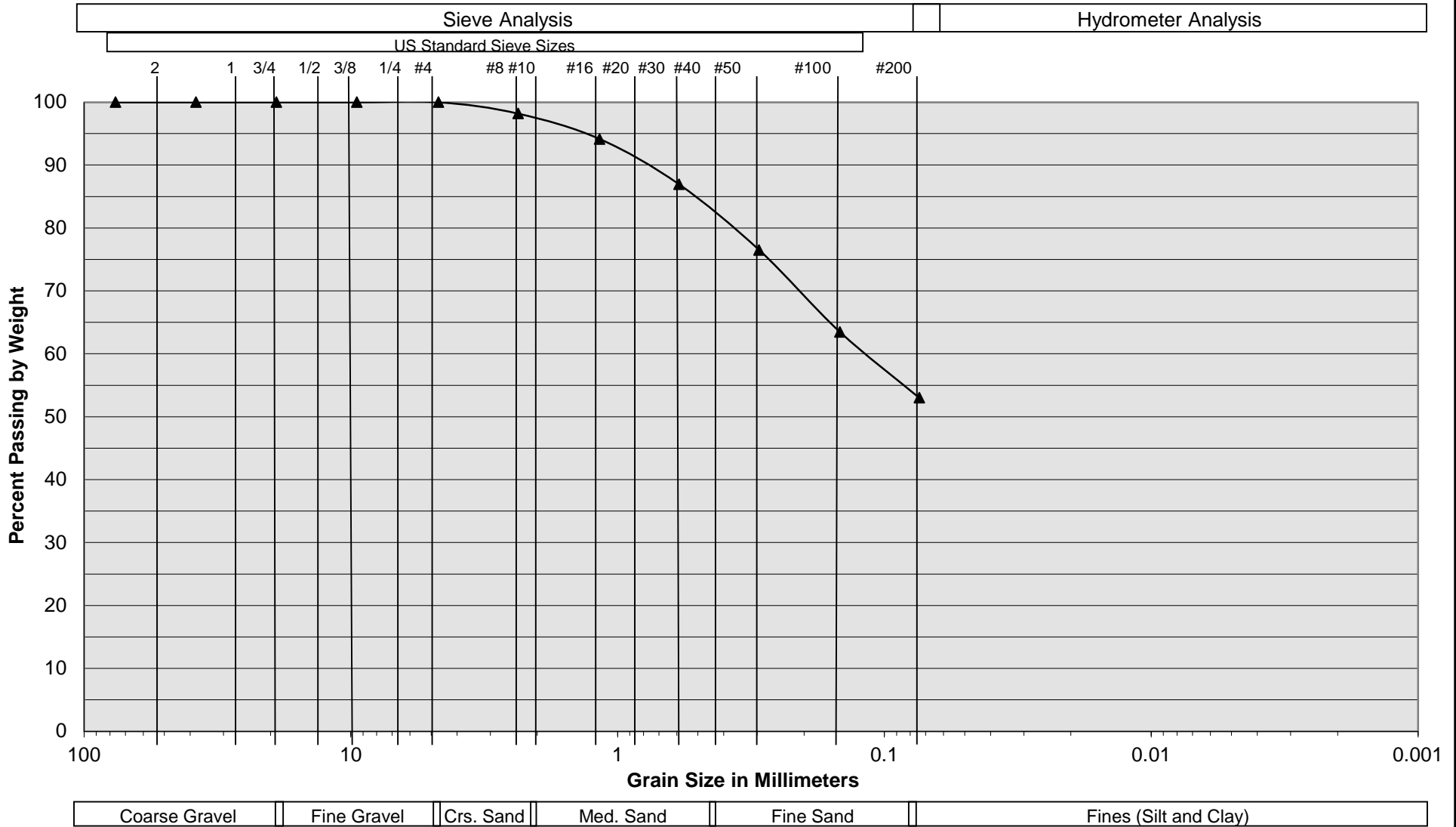

Sample Description	1-4 @ 8½'
Soil Classification	Brown Clayey fine to medium Sand to fine to medium Sandy Clay, trace to little Silt

Proposed Maintenance Building and Parking Lot
 Perris, California
 Project No. 22G184-2
PLATE C- 4



SOUTHERN CALIFORNIA GEOTECHNICAL
A California Corporation

Appendix 4: Historical Site Conditions

Phase I Environmental Site Assessment or Other Information on Past Site Use

PARTNER

Engineering and Science, Inc.



PHASE I ENVIRONMENTAL SITE ASSESSMENT REPORT

Nance Street

Northwest Corner of Nance Street and North
Webster Avenue
Perris, California 92571

Report Date: June 1, 2022
Partner Project No. 22-366784.1



Prepared for:

Lake Creek Industrial LLC

1302 Brittany Cross Road
Santa Ana, California 92705

June 1, 2022

Mr. Michael Johnson
Lake Creek Industrial LLC
1302 Brittany Cross Road
Santa Ana, California 92705

Subject: Phase I Environmental Site Assessment
Nance Street
Northwest Corner of Nance Street and North Webster Avenue
Perris, California 92571
Partner Project No. 22-366784.1

Dear Mr. Johnson:

Partner Engineering and Science, Inc. (Partner) is pleased to provide the results of the *Phase I Environmental Site Assessment* (Phase I ESA) report of the abovementioned address (the "subject property"). This assessment was performed in conformance with the scope and limitations as detailed in the ASTM Practice E1527-13 and E1527-21 Standard Practice for Environmental Site Assessments: Phase I Environmental Site Assessment Process.

The Phase I Environmental Site Assessment is designed to provide you with an assessment concerning environmental conditions (limited to those issues identified in the report) as they exist at the subject property. This assessment included a site reconnaissance as well as research and interviews with representatives of the public, property ownership, site manager, and regulatory agencies. An assessment was made, conclusions stated, and recommendations outlined.

We appreciate the opportunity to provide environmental services to you. If you have any questions concerning this report, or if we can assist you in any other matter, please contact me at (310) 622-8855.

Sincerely,



Debbie Stott, P.G.
Principal

EXECUTIVE SUMMARY

Partner Engineering and Science, Inc. (Partner) has performed a Phase I Environmental Site Assessment (ESA) in accordance with the scope of work and limitations of ASTM Standard Practice E1527-13 and E1527-21, the Environmental Protection Agency Standards and Practices for All Appropriate Inquiries (AAI) (40 CFR Part 312) for the property located at the northwest corner of Nance Street and North Webster Avenue in the City of Perris, Riverside County, California (the "subject property"). The Phase I Environmental Site Assessment is designed to provide Lake Creek Industrial with an assessment concerning environmental conditions (limited to those issues identified in the report) as they exist at the subject property.

Property Description

The subject property is located on the northwest corner of the intersection of Nance Street and North Webster Avenue, within a generally commercial, light industrial and rural residential area of Riverside County. Please refer to the table below for further description of the subject property:

Subject Property Data

Address:	No assigned addresses identified
Property Use:	Vacant land
Number of Buildings:	0
Assessor's Parcel Number (APN):	314-153-058, -060, -062, -064, -066, -068, -070, and -082
Current Tenants:	Vacant
Zoning:	Commercial (PVCC SP)
Site Assessment Performed By:	Heather Hodgetts of Partner
Site Assessment Conducted On:	May 20, 2022

The subject property consists of eight parcels of vacant land. The subject property is covered with low lying vegetation. At the time of the site visit, several parked cars and trucks were observed along the eastern and southeastern boundaries of the site. Stockpiled soil, sand bags, and minor debris was observed on the northeastern and eastern portions of the property. No other evidence of illegal dumping of solid waste was observed on the subject property during the Partner site reconnaissance.

No hazardous substances or petroleum products were observed on the subject property during the site reconnaissance. No evidence of aboveground storage tanks (ASTs) or underground storage tanks (USTs) such as fill ports, piping, or vent pipes was observed or reported onsite.

Based on the historical research and interviews, the subject property was agriculturally developed or vacant land from 1938 to present. No assigned addresses were identified for the subject property.

The agency database report obtained from May 10, 2022 did not identify the subject property.

During the vicinity reconnaissance, Partner observed the following land use on properties in the immediate vicinity of the subject property:

Immediately Surrounding Properties

North:	Vacant land, followed by Harley Knox Boulevard, vacant land and March Air Force Base.
Northeast:	North Webster Avenue/Harley Knox Boulevard roundabout, followed vacant land.

Immediately Surrounding Properties

- East:** North Webster Avenue, followed by IAA-ACE Perris 2 (775 Harley Knox Boulevard).
- Southeast:** Intersection of West Nance Street and North Webster Avenue, followed by vacant land,
- South:** West Nance Street, followed by a mobile home (953 West Nance Street), vacant land, Auto Aide Towing (845 West Nance Street), and truck trailer lot (4990 North Webster Avenue).
- Southwest:** West Nance Street, followed by a mobile home (953 West Nance Street) and vacant land,
- West:** Vacant land, followed by residences/commercial properties at 4611 and 4697 Nevada Avenue.
- Northwest:** Vacant land.

No environmental concerns associated with adjacent properties were identified based on visual observation from publicly accessible rights-of-way.

No potential vapor intrusion concerns were identified onsite nor from offsite facilities.

According to information obtained from the California State Water Resource Control Board online database, GeoTracker, for a nearby property (Case Number T060652454 – Shell Perris #121222 at 4039 North Perris Boulevard) and topographic map interpretation, groundwater in the vicinity of the subject property is present at a depth of 80 feet below ground surface (bgs) and flows toward the west-southwest.

Findings and Opinions

Recognized Environmental Condition

A *recognized environmental condition (REC)* refers to the presence of hazardous substances or petroleum products in, on, or at the subject property due to a release to the environment; the likely presence of hazardous substances or petroleum products in, on, or at the subject property due to a release or likely release to the environment; or the presence of hazardous substances or petroleum products in, on, or at the subject property under conditions that pose a material threat of a future release to the environment. The following was identified during the course of this assessment:

- Partner did not identify any RECs during the course of this assessment.

Controlled Recognized Environmental Condition

A *controlled recognized environmental condition (CREC)* refers to a REC affecting the subject property that has been addressed to the satisfaction of the applicable regulatory authority or authorities with hazardous substances or petroleum products allowed to remain in place subject to implementation of required controls (for example, activity and use limitations or other property use limitations). The following was identified during the course of this assessment:

- Partner did not identify any CRECs during the course of this assessment.

Historical Recognized Environmental Condition

A *historical recognized environmental condition (HREC)* refers to a previous release of hazardous substances or petroleum products affecting the subject property that has been addressed to the satisfaction of the applicable regulatory authority or authorities and meeting unrestricted use criteria established by the applicable regulatory authority or authorities without subjecting the subject property to any controls (for example, activity and use limitations or other property use limitations). The following was identified during the course of this assessment:

- Partner did not identify any HRECs during the course of this assessment.

Business Environmental Risk

A *Business Environmental Risks (BER)* is a risk which can have a material environmental or environmentally driven impact on the business associated with the current or planned use of commercial real estate, not necessarily related to those environmental issues required to be investigated in this practice. The following was identified during the course of this assessment:

- Partner did not identify any BERs during the course of this assessment.

Significant Data Gaps

No significant data gaps affecting the ability of the Environmental Professional to identify a REC were encountered during this assessment.

Conclusions and Recommendations

Partner has performed a Phase I Environmental Site Assessment in conformance with the scope and limitations of ASTM Practice E1527-13 and E1527-21 of the property at the northwest corner of Nance Street and North Webster Avenue in the City of Perris, Riverside County, California (the "subject property"). Any exceptions to, or deletions from, this practice are described in Section 1.5 of this report.

This assessment has revealed no evidence of RECs, CRECs, HRECs, or BERs in connection with the subject property. Based on the conclusions of this assessment, Partner recommends no further investigation of the subject property at this time.

TABLE OF CONTENTS

1.0	INTRODUCTION.....	1
1.1	Purpose.....	1
1.2	Scope of Work	1
1.3	Limitations	2
1.4	User Reliance	3
1.5	Limiting Conditions.....	3
2.0	SITE DESCRIPTION	4
2.1	Site Location and Legal Description.....	4
2.2	Current Property Use.....	4
2.3	Current Use of Adjacent Properties.....	4
2.4	Physical Setting Sources	4
2.4.1	Topography	4
2.4.2	Hydrology.....	5
2.4.3	Geology/Soils.....	5
2.4.4	Flood Zone Information.....	5
3.0	HISTORICAL INFORMATION	6
3.1	Aerial Photograph Review.....	6
3.2	Fire Insurance Maps.....	7
3.3	City Directories	7
3.4	Historical Topographic Maps.....	7
4.0	REGULATORY RECORDS REVIEW.....	9
4.1	Regulatory Agencies.....	9
4.1.1	Health Department	9
4.1.2	Air Pollution Control Agency	9
4.1.3	Regional Water Quality Agency.....	9
4.1.4	Department of Toxic Substances Control	9
4.1.5	Building Department	10
4.1.6	Planning Department	10
4.1.5	Oil & Gas Exploration	10
4.1.6	Assessor's Office.....	11
4.2	Mapped Database Records Search	11
4.2.1	Regulatory Database Summary	12
4.2.2	Subject Property Listings.....	12
4.2.3	Adjoining Property Listings.....	12
4.2.4	Surrounding Area Listings of Concern to Subject Property	13
4.2.5	Unplottable Listings	14
5.0	USER PROVIDED INFORMATION AND INTERVIEWS	15
5.1	Interviews	15
5.1.1	Interview with Owner.....	15
5.1.2	Interview with Report User.....	16
5.1.3	Interview with Key Site Manager.....	16
5.1.4	Interviews with Past Owners, Operators and Occupants.....	16

5.1.5	Interview with Others	16
5.2	User Provided Information	16
5.2.1	Title Records, Environmental Liens, and AULs	16
5.2.2	Specialized Knowledge	17
5.2.3	Actual Knowledge of the User	17
5.2.4	Valuation Reduction for Environmental Issues.....	17
5.2.5	Commonly Known or Reasonably Ascertainable Information.....	17
5.2.6	Previous Reports and Other Provided Documentation.....	17
6.0	SITE RECONNAISSANCE	18
6.1	General Site Characteristics.....	18
6.2	Potential Environmental Hazards.....	19
6.3	Non-ASTM Services.....	20
6.3.1	Asbestos-Containing Materials (ACMs).....	20
6.3.2	Lead-Based Paint (LBP)	20
6.3.3	Radon.....	20
6.3.4	Lead in Drinking Water	21
6.3.5	Mold.....	21
6.3.6	Wetlands.....	21
6.4	Adjoining Property Reconnaissance	21
7.0	VAPOR ENCROACHMENT CONDITIONS	22
8.0	FINDINGS AND CONCLUSIONS	23
9.0	SIGNATURES OF ENVIRONMENTAL PROFESSIONALS.....	25
10.0	REFERENCES.....	26

Figures

- Figure 1** Site Location Map
- Figure 2** Site Plan
- Figure 3** Topographic Map

Appendices

- Appendix A** Site Photographs
- Appendix B** Historical/Regulatory Documentation
- Appendix C** Regulatory Database Report
- Appendix D** Qualifications

1.0 INTRODUCTION

Partner Engineering and Science, Inc. (Partner) has performed a Phase I Environmental Site Assessment (ESA) in conformance with the scope and limitations of ASTM Standard Practice E1527-13 and the Environmental Protection Agency Standards and Practices for All Appropriate Inquiries (AAI) (40 CFR Part 312) for the property at 150 Harley Knox Boulevard in the Cities of Perris and Moreno Valley, Riverside County, California (the "subject property"). Any exceptions to, or deletions from, this scope of work are described in the report.

1.1 Purpose

The purpose of this ESA is to identify existing or potential Recognized Environmental Conditions (as defined by ASTM Standard E1527-13) affecting the subject property that: 1) constitute or result in a material violation or a potential material violation of any applicable environmental law; 2) impose any material constraints on the operation of the subject property or require a material change in the use thereof; 3) require clean-up, remedial action or other response with respect to Hazardous Substances or Petroleum Products on or affecting the subject property under any applicable environmental law; 4) may affect the value of the subject property; and 5) may require specific actions to be performed with regard to such conditions and circumstances. The information contained in the ESA Report will be used by Client to: 1) evaluate its legal and financial liabilities for transactions related to foreclosure, purchase, sale, loan origination, loan workout or seller financing; 2) evaluate the subject property's overall development potential, the associated market value and the impact of applicable laws that restrict financial and other types of assistance for the future development of the subject property; and/or 3) determine whether specific actions are required to be performed prior to the foreclosure, purchase, sale, loan origination, loan workout or seller financing of the subject property.

This ESA was performed to permit the *User* to satisfy one of the requirements to qualify for the innocent landowner, contiguous property owner, or bona fide prospective purchaser limitations on scope of Comprehensive Environmental Response, Compensation and Liability Act (CERCLA) (42 U.S.C. §9601) liability (hereinafter, the "*landowner liability protections*," or "*LLPs*"). ASTM Standard E1527-13 constitutes "*all appropriate inquiry* into the previous ownership and uses of the *property* consistent with good commercial or customary practice" as defined at 42 U.S.C. §9601(35)(B).

1.2 Scope of Work

The scope of work for this ESA is in accordance with the requirements of ASTM Standard E1527-13. This assessment included: 1) a property and adjacent site reconnaissance; 2) interviews with key personnel; 3) a review of historical sources; 4) a review of regulatory agency records; and 5) a review of a regulatory database report provided by a third-party vendor. Partner contacted local agencies, such as environmental health departments, fire departments and building departments in order to determine any current and/or former hazardous substances usage, storage and/or releases of hazardous substances on the subject property. Additionally, Partner researched information on the presence of activity and use limitations (AULs) at these agencies. As defined by ASTM E1527-13, AULs are the legal or physical restrictions or limitations on the use of, or access to, a site or facility: 1) to reduce or eliminate potential

exposure to hazardous substances or petroleum products in the soil or groundwater on the subject property; or 2) to prevent activities that could interfere with the effectiveness of a response action, in order to ensure maintenance of a condition of no significant risk to public health or the environment. These legal or physical restrictions, which may include institutional and/or engineering controls (IC/ECs), are intended to prevent adverse impacts to individuals or populations that may be exposed to hazardous substances and petroleum products in the soil or groundwater on the property.

If requested by Client, this report may also include the identification, discussion of, and/or limited sampling of asbestos-containing materials (ACMs), lead-based paint (LBP), mold, and/or radon.

1.3 Limitations

Partner warrants that the findings and conclusions contained herein were accomplished in accordance with the methodologies set forth in the Scope of Work. These methodologies are described as representing good commercial and customary practice for conducting an ESA of a property for the purpose of identifying recognized environmental conditions. There is a possibility that even with the proper application of these methodologies there may exist on the subject property conditions that could not be identified within the scope of the assessment or which were not reasonably identifiable from the available information. Partner believes that the information obtained from the record review and the interviews concerning the subject property is reliable. However, Partner cannot and does not warrant or guarantee that the information provided by these other sources is accurate or complete. The conclusions and findings set forth in this report are strictly limited in time and scope to the date of the evaluations. The conclusions presented in the report are based solely on the services described therein, and not on scientific tasks or procedures beyond the scope of agreed-upon services or the time and budgeting restraints imposed by the Client. No other warranties are implied or expressed.

Some of the information provided in this report is based upon personal interviews, and research of available documents, records, and maps held by the appropriate government and private agencies. This report is subject to the limitations of historical documentation, availability, and accuracy of pertinent records, and the personal recollections of those persons contacted.

This practice does not address requirements of any state or local laws or of any federal laws other than the all appropriate inquiry provisions of the LLPs. Further, this report does not intend to address all of the safety concerns, if any, associated with the subject property.

Environmental concerns, which are beyond the scope of a Phase I ESA as defined by ASTM include the following: ACMs, LBP, radon, and lead in drinking water. These issues may affect environmental risk at the subject property and may warrant discussion and/or assessment; however, are considered non-scope issues. If specifically requested by the Client, these non-scope issues are discussed in Section 6.3.

1.4 User Reliance

Lake Creek Industrial engaged Partner to perform this assessment in accordance with an agreement governing the nature, scope and purpose of the work as well as other matters critical to the engagement. All reports, both verbal and written, are for the sole use and benefit of Lake Creek Industrial and its entities. Either verbally or in writing, third parties may come into possession of this report or all or part of the information generated as a result of this work. In the absence of a written agreement with Partner granting such rights, no third parties shall have rights of recourse or recovery whatsoever under any course of action against Partner, its officers, employees, vendors, successors or assigns. Any such unauthorized user shall be responsible to protect, indemnify and hold Partner, Client and their respective officers, employees, vendors, successors and assigns harmless from any and all claims, damages, losses, liabilities, expenses (including reasonable attorneys' fees) and costs attributable to such Use. Unauthorized use of this report shall constitute acceptance of and commitment to these responsibilities, which shall be irrevocable and shall apply regardless of the cause of action or legal theory pled or asserted. Additional legal penalties may apply.

This report has been completed under specific Terms and Conditions relating to scope, relying parties, limitations of liability, indemnification, dispute resolution, and other factors relevant to any reliance on this report. Any parties relying on this report do so having accepted Partner's standard Terms and Conditions, a copy of which can be found at <http://www.partneresi.com/terms-and-conditions.php>.

1.5 Limiting Conditions

The findings and conclusions contain all of the limitations inherent in these methodologies that are referred to in ASTM E1527-13.

Specific limitations and exceptions to this ESA are more specifically set forth below:

- Interviews with past owners, operators and occupants were not reasonably ascertainable and thus constitute a data gap.
- An environmental cleanup lien search was not performed. However, it is Partner's opinion that the lack of the lien search does not represent a significant data gap, in that it does not impact Partner's ability to identify recognized environmental conditions at the subject property and therefore it does not alter the conclusions of this report. Preliminary title reports provided by Lake Creek Industrial did not indicate environmental liens filed against the property. According to the EDR Report, NPL (Superfund) and other environmental liens are not associated with the subject property. Based on available information, no environmental liens appear to be associated with the subject property.

2.0 SITE DESCRIPTION

2.1 Site Location and Legal Description

The subject property is located at the northwest corner of Nance Street and North Webster Avenue in the City of Perris, Riverside County, California. The subject property was inspected by Heather Hodgetts of Partner on May 20, 2022. The weather at the time of the site visit was cloudy and in the mid-60s (degrees Fahrenheit). According to the Riverside County Assessor, is identified by Assessor's Parcel Numbers 302-314-153-058, -060, -062, -064, -066, -068, -070, and -082.

Please refer to Figure 1: Site Location Map, Figure 2: Site Plan, Figure 3: Topographic Map, and Appendix A: Site Photographs for the location and site characteristics of the subject property.

2.2 Current Property Use

The subject property consists of eight parcels of vacant land. The subject property is covered with low lying vegetation. At the time of the site visit, several parked cars and trucks were observed along the eastern and southeastern boundaries of the site. Stockpiled soil, sand bags, and minor debris was observed on the northeastern and eastern portions of the property. No other evidence of illegal dumping of solid waste was observed on the subject property during the Partner site reconnaissance.

2.3 Current Use of Adjacent Properties

During the vicinity reconnaissance, Partner observed the following land use on properties in the immediate vicinity of the subject property:

Immediately Surrounding Properties

- North:** Vacant land, followed by Harley Knox Boulevard, vacant land and March Air Force Base.
- Northeast:** North Webster Avenue/Harley Knox Boulevard roundabout, followed vacant land.
- East:** North Webster Avenue, followed by IAA-ACE Perris 2 (775 Harley Knox Boulevard).
- Southeast:** Intersection of West Nance Street and North Webster Avenue, followed by vacant land,
- South:** West Nance Street, followed by a mobile home (953 West Nance Street), vacant land, Auto Aide Towing (845 West Nance Street), and truck trailer lot (4990 North Webster Avenue).
- Southwest:** West Nance Street, followed by a mobile home (953 West Nance Street) and vacant land,
- West:** Vacant land, followed by residences/commercial properties at 4611 and 4697 Nevada Avenue.
- Northwest:** Vacant land.

No environmental concerns associated with adjacent properties were identified based on visual observation from publicly accessible rights-of-way.

2.4 Physical Setting Sources

2.4.1 Topography

The United States Geological Survey (USGS) *Perris, California* Quadrangle 7.5-minute series topographic map was reviewed for this ESA. According to the contour lines on the topographic map, the subject property is located at approximately 1,480 feet above mean sea level (MSL). The contour lines in the area of the subject property indicate the area is sloping toward the west-southwest.

A copy of the most recent topographic map is included as Figure 3 of this report.

2.4.2 Hydrology

According to information obtained from the California State Water Resource Control Board online database, GeoTracker, for a nearby property (Case Number T060652454 – Shell Perris #121222 at 4039 North Perris Boulevard) and topographic map interpretation, groundwater in the vicinity of the subject property is present at a depth of 80 feet below ground surface (bgs) and flows toward the west-southwest.

No settling ponds, lagoons, surface impoundments, wetlands or natural catch basins were observed on the subject property during this assessment. The nearest surface water is the Perris Valley Storm Drain (Southern Storm Drain) located 0.16-miles to the north of the subject property.

2.4.3 Geology/Soils

The site is located in the Peninsular Ranges geomorphic province. The Peninsular Ranges are a northwest-southwest oriented complex of blocks separated by similarly trending faults. They extend from the Transverse Ranges and the Los Angeles Basin south to the Mexican border and beyond to the tip of Baja California and are bounded on the east by the Colorado Desert and the Gulf of California. The Peninsular Ranges contain minor Jurassic and extensive Cretaceous igneous rocks associated with the Nevadan plutonism. Marine Cretaceous sedimentary rocks are well represented and post-Cretaceous rocks form a restricted veneer of volcanic, marine, and nonmarine sediments.

Based on information obtained from the USDA Natural Resources Conservation Service Web Soil Survey online database, the subject property is mapped as Pachappa fine sandy and Exeter sandy loam. These series consists of well drained alluvium derived from granite. Slopes range from 0 to 2 percent.

2.4.4 Flood Zone Information

Partner performed a review of the Flood Insurance Rate Map, published by the Federal Emergency Management Agency. According to Community Panel Number 06065C1430H, dated August 18, 2014, the majority of the subject property appears to be located in Zone D, an area of undetermined flood risk. The southwest corner of the subject property is mapped in Zone X, an area of minimal flood risk.

3.0 HISTORICAL INFORMATION

Partner obtained historical use information about the subject property from a variety of sources. A chronological listing of the historical data found is summarized in the table below:

Historical Use Information

Years	Resource	Description/Use
1938-Present	Aerial Photographs, Topographic Map, Interviews	Agricultural or Vacant Land

Common agricultural practices can result in residual concentrations of fertilizers, pesticides or herbicides in near-surface soil, though not generally at concentrations that pose a significant health risk. It is Partner’s opinion that, the property has been tilled, and remaining pesticide or herbicide residues, if any, are likely to have been dispersed and therefore are unlikely to impact human health or the environment. Accordingly, no further investigation is recommended regarding potential residual pesticides.

3.1 Aerial Photograph Review

Partner obtained available aerial photographs of the subject property and surrounding area from Environmental Risk Information Services (ERIS) on May 10, 2022. The inferred uses of the subject property and adjoining properties as interpreted from the aerial photographs in Appendix B are tabulated below:

Date:	1938-1997	Scale:	1"=500'
Subject Property:	Agricultural land.		
North:	Agricultural land. By 1953, a pond (as seen on the topographic maps) or structure is located to the north. March Air Force Base is depicted further to the north.		
Northeast:	North Webster Avenue, followed by agricultural land.		
East:	North Webster Avenue, followed by agricultural land.		
Southeast:	West Nance Street and North Webster Avenue intersection, followed by agricultural land.		
South:	West Nance Street, followed by agricultural land. By 1976 and 1980, structure are located to the south.		
Southwest:	West Nance Street, followed by agricultural land. By 1980, a residence is located to the southwest.		
West:	Agricultural land. By 1953, several farming structures are located further to the west.		
Northwest:	Agricultural land.		

Date:	2002	Scale:	1"=500'
Subject Property:	Agricultural or vacant land. In 2018, parked cars are located along the southern boundary of the site, adjacent to West Nance Street.		
North:	Vacant land and Harley Knox Boulevard (roundabout added by 2018). March Air Force Base is depicted further to the north.		
Northeast	North Webster Avenue and Harley Knox Boulevard (roundabout added by 2018), followed by agricultural land.		
East:	North Webster Avenue, followed by agricultural land. By 2020, a paved parking lot and commercial building is present adjacent to the east.		
Southeast	West Nance Street and North Webster Avenue intersection, followed by agricultural		

- land.
- South:** West Nance Street, followed by agricultural or vacant land and commercial properties.
- Southwest:** West Nance Street, followed by agricultural land and a residence.
- West:** Vacant land, followed by residential/commercial properties.
- Northwest:** Vacant land.

Copies of select aerial photographs are included in Appendix B of this report.

3.2 Fire Insurance Maps

Partner reviewed the collection of Fire insurance maps (FIMs) from ERIS on May 9, 2022. FIM coverage was not available for the subject property.

A copy of the Sanborn Fire insurance map "No Coverage" letter is included in Appendix B of this report.

3.3 City Directories

Partner reviewed historical city directories obtained from ERIS on May 16, 2022 for past names and businesses that were listed for the subject property and adjoining properties. City directories were not identified for the subject property. The findings are tabulated below:

City Directory Search for South Adjoining Properties

Year(s)	Occupant Listed
2000-2012	Individual residential listings (953 West Nance Street)
2003	Orange Auto Classics (845 West Nance Street)
2008	OC Collision, Travis L Haugen (845 West Nance Street)
2008-2020	Dan Ruth (845 West Nance Street)
2016-2020	Virginni Schexnayde (845 West Nance Street)
2020	Austin Kenneth, All Transport (4590 North Webster Avenue)
2020	U-Haul Neighborhood Dealer (845 West Nance Street)

According to the city directory review, the adjoining properties have been occupied by residential and commercial listings since 2000. Based on the city directory review, no environmentally sensitive listings were identified for the adjoining property addresses.

Copies of reviewed city directories are included in Appendix B of this report.

3.4 Historical Topographic Maps

Partner reviewed historical topographic maps obtained from ERIS on May 10, 2022. The following inferred uses of the subject property and adjoining properties interpreted from topographic maps in Appendix B and are tabulated below:

Date: 1942, 1943, 1953

Subject Property: Vacant land.
North: Vacant land. By 1953, March Air Force Base is depicted further to the north.
Northeast: North Webster Avenue (formerly known as Heacock), followed by vacant land.
East: North Webster Avenue (formerly known as Heacock), followed by vacant land.
Southeast: West Nance Street and North Webster Avenue intersection, followed by vacant land.
South: West Nance Street, followed by vacant land.
Southwest: West Nance Street, followed by vacant land.
West: Vacant land.
Northwest: Vacant land.

Date: 1967, 1973, 1979

Subject Property: Vacant land. The subject property appears to be located with a March Air Force Base boundary line.
North: Vacant land and two ponds. March Air Force Base is depicted further to the north.
Northeast: North Webster Avenue, followed by vacant land.
East: North Webster Avenue, followed by vacant land.
Southeast: West Nance Street and North Webster Avenue intersection, followed by vacant land.
South: West Nance Street, followed by vacant land.
Southwest: West Nance Street, followed by vacant land.
West: Vacant land.
Northwest: Vacant land, followed by three structures along Nevada Avenue.

Date: 2015, 2018, 2021

Subject Property: Vacant land. The subject property appears to be located adjacent to a March Air Force Base boundary line.
North: Vacant land. March Air Force Base is depicted further to the north.
Northeast: North Webster Avenue, followed by vacant land.
East: North Webster Avenue, followed by vacant land.
Southeast: West Nance Street and North Webster Avenue intersection, followed by vacant land.
South: West Nance Street, followed by vacant land.
Southwest: West Nance Street, followed by vacant land.
West: Vacant land.
Northwest: Vacant land, followed by three structures along Nevada Avenue.

Copies of reviewed topographic maps are included in Appendix B of this report.

4.0 REGULATORY RECORDS REVIEW

4.1 Regulatory Agencies

4.1.1 Health Department

Regulatory Agency Data

Name of Agency:	Riverside County Health Department of Environmental Health (RCDEH)
Point of Contact:	Records Coordinator
Agency Address:	4065 County Circle Drive, Room 104
Agency Phone Number:	(951) 358-7018
Date of Contact:	May 9, 2022
Method of Communication:	Email
Summary of Communication:	The RCDEH Hazardous Materials Management Division is unable to provide information about sites based on APN's or similar geographic site data. No addresses have been identified for the subject property.

4.1.2 Air Pollution Control Agency

Regulatory Agency Data

Name of Agency:	South Coast Air Quality Management District (SCAQMD)
Point of Contact:	http://www.aqmd.gov/nav/FIND/facility-information-detail
Agency Address:	21865 Copley Drive, Diamond Bar, California 91765
Agency Phone Number:	(909) 396-2000
Date of Contact:	May 9, 2022
Method of Communication:	Online
Summary of Communication:	No Permits to Operate (PTO), Notices of Violation (NOV), or Notices to Comply (NTC) or the presence of AULs, dry cleaning machines, or USTs were on file for the subject property with the SCAQMD.

4.1.3 Regional Water Quality Agency

Regulatory Agency Data

Name of Agency:	Regional Water Quality Control Board (RWQCB)
Point of Contact:	http://geotracker.waterboards.ca.gov/
Agency Address:	3737 Main St Ste 500, Riverside, CA 92501
Agency Phone Number:	(951) 782-4130
Date of Contact:	May 9, 2022
Method of Communication:	Online database
Summary of Communication:	The subject property was not identified on the GeoTracker database.

4.1.4 Department of Toxic Substances Control

Regulatory Agency Data

Name of Agency:	California Department of Toxic Substances Control (DTSC)
Agency Address:	http://www.envirostor.dtsc.ca.gov/public/

Regulatory Agency Data

Agency Phone Number: <http://www.hwts.dtsc.ca.gov/>
(714) 484-5400
Date of Contact: May 9, 2022
Method of Communication: Online
Summary of Communication:

The subject property was not identified in the online DTSC EnviroStor System and DTSC Hazardous Waste Tracking System records databases.

4.1.5 Building Department

Regulatory Agency Data

Name of Agency: City of Perris Building & Safety (PBS)
Point of Contact: <https://www.cityofperris.org/departments/development-services/building-department>
Agency Address: 101 North D Street, Perris, CA 92570
Agency Phone Number: (951) 943-6100
Date of Contact: May 9, 2022
Method of Communication: Online
Summary of Communication: Records were not identified in the PBS online database for subject property parcels (APNs 314-153-058, -060, -062, -064, -066, -068, -070, and -082). No addresses were identified for the subject property.

4.1.6 Planning Department

Regulatory Agency Data

Name of Agency: City of Perris Planning Department
Point of Contact: <https://www.cityofperris.org/departments/development-services/zoning>
Agency Address: 101 North D Street, Perris, CA 92570
Agency Phone Number: (951) 943-6100
Date of Contact: May 9, 2022
Method of Communication: Online
Summary of Communication: According to records reviewed, the subject property is zoned for industrial development (Perris Valley Commerce Center Specific Plan - PVCC SP) by the City of Perris.

4.1.5 Oil & Gas Exploration

Regulatory Agency Data

Name of Agency: California Division of Oil, Gas and Geothermal Resources (CalGem)
Point of Contact: <http://maps.conservation.ca.gov/doms/doms-app.html>
Agency Address: 801 K Street, MS 24-01, Sacramento, California 95814
Agency Phone Number: (916) 322-1080
Date of Contact: May 9, 2022
Method of Communication: Online
Summary of Communication: According to CalGem, no oil or gas wells are located on or adjacent to the subject property.

4.1.6 Assessor's Office

Regulatory Agency Data

Name of Agency:	Riverside County Assessor (RCA)
Point of Contact:	https://ca-riverside-acr.publicaccessnow.com/
Agency Address:	4080 Lemon St, 1st Floor Riverside, CA 92501
Agency Phone Number:	(951) 955-9553
Date of Contact:	May 9, 2022
Method of Communication:	Online
Summary of Communication:	According to records reviewed, the subject property is identified by APNs 314-153-058, -060, -062, -064, -066, -068, -070, and -082. No addresses were identified for the subject property.

Copies of pertinent documents obtained by Partner from the above-referenced agencies are included in Appendix B.

4.2 Mapped Database Records Search

The regulatory database report provided by Environmental Risk Information Services (ERIS) documents the listing of sites identified on federal, state, county, city, and tribal (when applicable) standard source environmental databases within the approximate minimum search distance (AMSD) specified by ASTM E1527-13 and E1527-21. The data from these sources are updated as these data are released and integrated into one database. The information contained in this report was compiled from publicly available sources.

The environmental database information is used to identify environmental concerns in connection with the subject property. The listings also serve to identify the known indications of the storage, use, generation, disposal, or release of hazardous substance at the subject property and the potential for contaminants to migrate onto the subject property from off-site sources in groundwater or soil in the form of liquids or vapor.

Using the ASTM definition of migration, Partner considers the migration of hazardous substances or petroleum products in any form onto the subject property during the evaluation of each site listed on the radius report, which includes solid, liquid, and vapor.

4.2.1 Regulatory Database Summary

The following table lists the number of sites as categorized by the regulatory database within the prescribed AMSD. The locations of the sites are plotted utilizing a geographic information system, which geocodes the site addresses. The accuracy of the geocoded locations is approximately +/-300 feet.

Radius Report Data					
Database	AMSD Radius (mile)	Listings Identified		Surrounding Area Sites of Concern	
		Subject Property	Adjoining Properties		
Federal NPL	1.00	N	N	Y	
Delisted NPL Site	0.50	N	N	N	
Federal SEMS Site	0.50	N	N	N	
Federal SEMS-ARCHIVE	0.50	N	N	N	
Federal RCRA CORRACTS Facility	1.00	N	N	N	
Federal RCRA TSDF Facility	0.50	N	N	N	
Federal RCRA Generators Site (LQG, SQG, VSQG, CESQG, NonGen)	Subject and Adjoining	N	Y	N/A	
Federal IC/EC Registries	Subject Property	N	N/A	N/A	
Federal ERNS Site	Subject Property	N	N/A	N/A	
State/Tribal Equivalent NPL	1.00	N	N	N	
State/Tribal Equivalent CERCLIS	1.00	N	N	N	
State/Tribal Landfill/Solid Waste Disposal Site	0.50	N	N	N	
State/Tribal Leaking Storage Tank Site (LUST/LPST)	0.50	N	N	N	
State/Tribal Registered Storage Tank Sites (UST/AST)	Subject and Adjoining	N	N	N/A	
State/Tribal IC/EC Registries	Subject and Adjoining	N	N	N/A	
State/Tribal Voluntary Cleanup Sites (VCP)	0.50	N	N	N	
State/Tribal Spills	0.50	N	N	N	
Federal Brownfield Sites	0.50	N	N	N	
State Brownfield Sites	0.50	N	N	N	
Riverside County CUPA	Subject and Adjoining	N	N		

4.2.2 Subject Property Listings

The subject property is not identified in the regulatory database report.

4.2.3 Adjoining Property Listings

The following adjoining properties are identified in the regulatory database report, as discussed below:

- **Auto Aid (ERIS Map ID: 1)**, listed at 845 West Nance Street, located adjoining to the south, beyond West Nance Street, and hydrologically cross-gradient of the subject property. This facility is identified on the RCRA NonGen databases. No RCRA violations were listed. Based on the

regulatory status, it is Partner's opinion that these listings do not represent an environmental concern to the subject property.

- **Interinsurance Exchange of the Automobile Club (ERIS Map ID: 2)**, listed at 845 North Webster Avenue, located adjoining to the east, beyond North Webster Avenue, and hydrologically down- to cross-gradient of the subject property. This facility is identified on the RCRA NonGen databases. No RCRA violations were listed. Based on the regulatory status, it is Partner's opinion that these listings do not represent an environmental concern to the subject property.

Based on the findings, vapor migration is not expected to represent a significant environmental concern at this time.

4.2.4 Surrounding Area Listings of Concern to Subject Property

- The following site of concern was identified: The subject property is situated downgradient of known groundwater contamination, identified as the March Air Force Base/March Air Reserve Base (ARB) Superfund site, Former Fire Training Area (FT007). The facility is listed on the NPL. March ARB is located approximately 0.16-miles to the north-northwest. According to information obtained from the regulatory database report and the GeoTracker and the EnviroStor online databases, numerous releases have been discovered throughout the March ARB property since the late-1980s. Contaminated groundwater is known to have migrated off March ARB property to the southeast and is mapped beneath the subject property. Groundwater in the vicinity of the base has reportedly been impacted with by numerous hazardous substances, including volatile organic compounds (VOCs), specifically trichloroethylene (TCE), tetrachloroethylene (PCE), carbon tetrachloride (CTCL), as well as Perfluorooctane Sulfonic acid (PFOS), and Perfluorooctanoic acid (PFAS). VOC contamination in groundwater beneath and adjacent to Site FT007 was first investigated and remediated under Operable Unit 1 (OU1). A groundwater extraction and treatment system (GETS) was installed in 1991, to operate as an interim remedy to prevent further migration of TCE and PCE plumes at the base boundary.

According the Final (Revised) Expanded Inspection Report (ESI) for Perfluorooctane Sulfonic Acid and Perfluorooctanoic Acid for the former March Air Force Base dated December 2020, FT007 is a former fire-fighting training area for which previous investigations have confirmed the presence of PFOS and PFOA in groundwater at concentrations above the U.S. Environmental Protection Agency (USEPA) Lifetime Health Advisories (LHAs). The United States Air Force is currently focused on protecting human health primarily through the investigation of drinking water.

As a part of the field investigation, groundwater samples were collected from existing and newly installed groundwater monitoring wells. Twelve new groundwater monitoring wells were installed as nested wells within five separate boreholes strategically located to determine the horizontal and vertical extent of PFOS and PFOA in groundwater above the LHA. Currently, there are no legally enforceable federal or State of California criteria for PFAS. In October 2019, the DoD issued a memorandum identifying risk-based screening levels calculated using the USEPA Regional Screening Level (RSL) calculator for PFOA, PFOS, and PFBS in groundwater and soil.

In April 2021, the USEPA released an updated toxicity assessment for PFBS only, which resulted in revised screening levels for PFBS (USEPA, 2021). The most current USEPA RSLs for PFOS, PFOA, and PFBS, using the conservative residential scenario, will be used as screening levels. These screening values will be used to determine if further investigation is needed or if a site can proceed to closeout. The current residential screening levels for PFOS, PFOA, and PFBS, assuming a hazard quotient (HQ) of 0.1, are: for soil - 130 micrograms per kilogram (ug/kg); 130 ug/kg; and 1900 ug/kg; and for residential tap water – 40 nanograms per liter (ng/L); 40 ng/L; and 602 ng/L.

Attached figures indicated the subject property is depicted adjacent to the west of the FT007 Study Area Boundary. Attached figures indicated the PFOS+PFOA plume in the upper aquifer is mapped below the site vicinity to the east, northeast, and southeast nearby wells. PFOS and PFOA compounds are non-volatile, and therefore do not represent a vapor intrusion risk. Contaminated groundwater is actively being remediated at March AFB, and groundwater is not utilized at the subject property as source of drinking water. Based on regulatory oversight, the identification of a responsible party, and municipal water supply, the groundwater contamination associated with the nearby March ARB does not represent a significant environmental concern for the subject property.

Based on the findings, vapor migration is not expected to represent a significant environmental concern at this time.

4.2.5 Unplottable Listings

No unplottable listings are identified in the regulatory database report.

A copy of the regulatory database report is included in Appendix C of this report.

5.0 USER PROVIDED INFORMATION AND INTERVIEWS

In order to qualify for one of the *Landowner Liability Protections (LLPs)* offered by the Small Business Liability Relief and Brownfields Revitalization Act of 2001 (the *Brownfields Amendments*), the *User* must conduct the following inquiries required by 40 CFR 312.25, 312.28, 312.29, 312.30, and 312.31. The *User* should provide the following information to the *environmental professional*. Failure to provide this information could result in a determination that *all appropriate inquiries* is not complete. The *User* is asked to provide information or knowledge of the following:

- Review Title and Judicial Records for Environmental Liens and AULs
- Specialized Knowledge or Experience of the User
- Actual Knowledge of the User
- Reason for Significantly Lower Purchase Price
- Commonly Known or *Reasonably Ascertainable* information
- Degree of Obviousness
- Reason for Preparation of this Phase I ESA

Fulfillment of these user responsibilities is key to qualification for the identified defenses to CERCLA liability. Partner requested our Client to provide information to satisfy User Responsibilities as identified in Section 6 of the ASTM guidance.

Pursuant to ASTM E1527-13 and E1527-21, Partner requested the following site information from Lake Creek Industrial (User of this report).

User Responsibilities

Item	Provided By User	Not Provided By User
AAI User Questionnaire	X	
Title Records, Environmental Liens, and AULs	X	
Specialized Knowledge		X
Actual Knowledge		X
Valuation Reduction for Environmental Issues		X
Identification of Key Site Manager		X
Reason for Performing Phase I ESA	X	
Prior Environmental Reports		X
Other		X

5.1 Interviews

5.1.1 Interview with Owner

The owners of the subject property each completed a questionnaire covering the current and historical use of the subject property.

The subject property owners was not aware of any pending, threatened, or past litigation relevant to hazardous substances or petroleum products in, on, or from the subject property; any pending,

threatened, or past administrative proceedings relevant to hazardous substances or petroleum products in, on, or from the subject property; or any notices from a governmental entity regarding any possible violation of environmental laws or possible liability relating to hazardous substances or petroleum products.; any pending, threatened, or past administrative proceedings relevant to hazardous substances or petroleum products in, on, or from the subject property; or any notices from a governmental entity regarding any possible violation of environmental laws or possible liability relating to hazardous substances or petroleum products.

According to subject property owners, no addresses have been assign to the subject property. No USTs, ASTs, clarifiers, oil/water separators, groundwater monitoring wells, or hazardous substance use/storage /generation were identified on the subject property to the best of their knowledge. Copies of the questionnaires are provided in Appendix B.

5.1.2 Interview with Report User

Please refer to Section 5.2 below for information requested from the Report User. The information requested was not received prior to the issuance of this report. Because the Report User (Client) is a lender or potential purchaser, it is understood that the Report User would not have knowledge of the property that would significantly impact our ability to satisfy the objectives of this assessment. The lack of this information is not considered to represent a significant data gap.

5.1.3 Interview with Key Site Manager

See Section 5.1.1.

5.1.4 Interviews with Past Owners, Operators and Occupants

Interviews with past owners, operators and occupants were not conducted since information regarding the potential for contamination at the subject property was obtained from other sources.

5.1.5 Interview with Others

As the subject property is not an abandoned property as defined in ASTM 1527-13, interview with others were not performed.

5.2 User Provided Information

5.2.1 Title Records, Environmental Liens, and AULs

Partner was provided by Lake Creek Industrial with a Preliminary Title Reports issued by Lawyers Title Company and dated January 5, 2022 and March 30, 2022 for the subject property parcels. According to the Commitment for Title Insurance, the title to the subject property is currently vested in:

- APN: 314-153-082: Yvonne Chu, Trustee of the Yvonne Chu Family Trust, dated August 14, 2019, as to an undivided 2/3 interest, and Loreen G. Leung, as her sole and separate property, as to an undivided 1/3 interest.
- APNs: 314-153-064; 314-153-066; 314-153-068; 314-153-070: Venancio H. Reyes, Jr. and Armi M. Alian, husband and wife as joint tenants, as to an undivided 25% interest; Noli Tcruz and Isabel D.

Tacruz, husband and wife as joint tenants, as to an undivided 25% interest; Roberto S. Lacson and Bridget P. Lacson, husband and wife as joint tenants, as to an undivided 25% interest; and The Dcena Family Trust, Rogelio R. and Merlyn G. Docena as Trustees, as to an undivided 50% interest, all as tenants in common, (subject to Item 11, 12, 14 and 15).

- APNs: 314-153-058; 314-153-060; 314-153-062: Evangeline E. Canotal, Trustee, or her Successor(s) in Trust of The Canotal Family Trust dated 6-29-2007; and Paul O. Mallari and Fe B. Maliari, husband and wife as joint tenants as to an undivided 25% interest; Diosdado B. Tolentino and Lorna L. Tolentino, husband and wife as joint tenants as to an undivided 12.50% interest; Pilar B. Tolentino, a single woman as her sole and separate property as to an undivided 12.50% interest, all as tenants in common.

No apparent environmental liens or AULs were identified for the subject property based on the review of the Preliminary Title Report.

Copies are included in Appendix B.

5.2.2 Specialized Knowledge

No specialized knowledge of environmental conditions associated with the subject property was provided by the User at the time of the assessment.

5.2.3 Actual Knowledge of the User

No actual knowledge of any environmental lien or AULs encumbering the subject property or in connection with the subject property was provided by the User at the time of the assessment.

5.2.4 Valuation Reduction for Environmental Issues

No knowledge of valuation reductions associated with the subject property was provided by the User at the time of the assessment.

5.2.5 Commonly Known or Reasonably Ascertainable Information

The User did not provide information that is commonly known or *reasonably ascertainable* within the local community about the subject property at the time of the assessment.

5.2.6 Previous Reports and Other Provided Documentation

No previous reports or other pertinent documentation was provided to Partner for review during the course of this assessment.

6.0 SITE RECONNAISSANCE

The weather at the time of the site visit was cloudy. Refer to Section 1.5 for limitations encountered during the field reconnaissance and Sections 2.1 and 2.2 for subject property operations. The table below provides the site assessment details:

Site Assessment Data

Site Assessment Performed By:	Heather Hodgetts
Site Assessment Conducted On:	May 20, 2022

Partner was unaccompanied during the field reconnaissance activities.

No potential environmental concerns were identified during the onsite reconnaissance.

6.1 General Site Characteristics

6.1.1 *Solid Waste Disposal*

No solid waste is currently generated at the subject property. A few tires, wood pallets, and minor debris were observed on the east-northeastern portion of the property. No other evidence of illegal dumping of solid waste was observed on the subject property during the Partner site reconnaissance.

6.1.2 *Sewage Discharge and Disposal*

The municipal sanitary sewer system operated by the City of Perris services the subject property vicinity.

Sanitary discharges are not generated at the subject property. No wastewater treatment facilities are located on the subject property.

6.1.3 *Surface Water Drainage*

Storm water is removed from the subject property primarily by percolation to unpaved ground surfaces on the subject property.

The subject property does not appear to be a designated wetland area, based on information obtained from the United States Fish & Wildlife Service; however, a comprehensive wetlands survey would be required in order to formally determine actual wetlands on the subject property. No surface impoundments, wetlands, natural catch basins, settling ponds, or lagoons are located on the subject property. No drywells were identified on the subject property.

6.1.4 *Source of Heating and Cooling*

Electricity and natural gas are provided to the vicinity by Southern California Edison (SCE) and the Southern California Gas Company.

6.1.5 *Wells and Cisterns*

No aboveground evidence of wells or cisterns was observed during the site reconnaissance.

Water wells may be located at the subject property due to the historical agricultural use. If encountered, the water wells should be abandoned under local requirements.

6.1.6 Wastewater

Domestic wastewater is not generated at the subject property.

6.1.7 Septic Systems

No septic systems were observed or reported on the subject property.

6.1.8 Additional Site Observations

No other additional general site characteristics were observed during the site reconnaissance.

6.2 Potential Environmental Hazards

6.2.1 Hazardous Substances and Petroleum Products Used or Stored at the Site

No hazardous substances or petroleum products were observed on the subject property during the site reconnaissance.

6.2.2 Aboveground & Underground Hazardous Substance or Petroleum Product Storage Tanks (ASTs/USTs)

No evidence of ASTs or USTs such as fill ports, piping, or vent pipes was observed or reported onsite.

6.2.3 Evidence of Releases

No spills, stains or other indications that a surficial release has occurred at the subject property were observed.

6.2.4 Polychlorinated Biphenyls (PCBs)

No potential PCB-containing equipment (transformers, oil-filled switches, hoists, lifts, dock levelers, hydraulic elevators, etc.) was observed on the subject property during Partner's reconnaissance.

6.2.5 Strong, Pungent or Noxious Odors

No strong, pungent or noxious odors were evident during the site reconnaissance.

6.2.6 Pools of Liquid

No pools of liquid were observed on the subject property during the site reconnaissance.

6.2.7 Drains, Sumps and Clarifiers

No drains, sumps, or clarifiers were observed on the subject property during the site reconnaissance.

6.2.8 Pits, Ponds and Lagoons

No pits, ponds or lagoons were observed on the subject property.

6.2.9 Stressed Vegetation

No stressed vegetation was observed on the subject property.

6.2.10 Additional Potential Environmental Hazards

No additional environmental hazards, including landfill activities or radiological hazards, were observed.

6.3 Non-ASTM Services

6.3.1 Asbestos-Containing Materials (ACMs)

Asbestos is the name given to a number of naturally occurring, fibrous silicate minerals mined for their useful properties such as thermal insulation, chemical and thermal stability, and high tensile strength. The Occupational Safety and Health Administration (OSHA) regulation 29 CFR 1926.1101 requires certain construction materials to be *presumed* to contain asbestos, for purposes of this regulation. Construction materials including, but not limited to, thermal system insulation (TSI), surfacing material, and asphalt/vinyl flooring that are present in a building and that have not been appropriately tested may be considered "presumed asbestos-containing material" (PACM).

No buildings or structures are located on the subject property. As such, an asbestos evaluation was not required by the scope of services.

6.3.2 Lead-Based Paint (LBP)

Lead is a highly toxic metal that affects virtually every system of the body. LBP is defined as any paint, varnish, stain, or other applied coating that has 1 mg/cm² (or 5,000 ug/g or 0.5% by weight) or more of lead.

No buildings or structures are located on the subject property. As such, a LBP evaluation was not required by the scope of services.

6.3.3 Radon

Radon is a colorless, odorless, naturally occurring, radioactive, inert, gaseous element formed by radioactive decay of radium (Ra) atoms. The US EPA has prepared a map to assist National, State, and local organizations to target their resources and to implement radon-resistant building codes. The map divides the country into three Radon Zones, according to the table below:

EPA Radon Zones		
EPA Zones	Average Predicted Radon Levels	Potential
Zone 1	Exceed 4.0 pCi/L	Highest
Zone 2	Between 2.0 and 4.0 pCi/L	Moderate
Zone 3	Less than 2.0 pCi/L	Low

It is important to note that the EPA has found homes with elevated levels of radon in all three zones, and the US EPA recommends site-specific testing in order to determine radon levels at a specific location. However, the map does give a valuable indication of the propensity of radon gas accumulation in structures.

Radon sampling was not conducted as part of this assessment. Review of the US EPA Map of Radon Zones places the subject property in Zone 2. Based upon the radon zone classification and proposed commercial use, radon is not considered to be a significant environmental concern.

6.3.4 Lead in Drinking Water

According to available information, a public water system operated by the Eastern Municipal Water District (EMWD) serves the subject property vicinity. According to EMWD, the sources of public water for are rivers, lakes, streams, ponds, reservoirs, springs, local groundwater wells, surface water imported from Northern California and the Colorado River. According to the EMWD 2020 Water Quality Report, water supplied to the subject property is in compliance with all State and Federal regulations pertaining to drinking water standards, including lead and copper. There are no current water supplies onsite.

6.3.5 Mold

Molds are microscopic organisms found virtually everywhere, indoors and outdoors. Mold will grow and multiply under the right conditions, needing only sufficient moisture (e.g. in the form of very high humidity, condensation, or water from a leaking pipe, etc.) and organic material (e.g., ceiling tile, drywall, paper, or natural fiber carpet padding).

No buildings or structures are located on the subject property. As such, a mold evaluation was not required by the scope of services.

6.3.6 Wetlands

The subject property does not appear to be a designated wetland area, based on information obtained from the United States Fish & Wildlife Service; however, a comprehensive wetlands survey would be required in order to formally determine actual wetlands on the subject property. No surface impoundments, wetlands, natural catch basins, settling ponds, or lagoons are located on the subject property.

6.4 Adjoining Property Reconnaissance

The adjoining property reconnaissance consisted of observing the adjoining properties from the subject property premises. No items of environmental concern were identified on the adjoining properties during the site assessment, including hazardous substances, petroleum products, ASTs, USTs, evidence of releases, PCBs, strong or noxious odors, pools of liquids, sumps or clarifiers, pits or lagoons, stressed vegetation, or any other potential environmental hazards.

7.0 VAPOR ENCROACHMENT CONDITIONS

Partner conducted a limited non-intrusive vapor screening on the subject property to identify, to the extent feasible, the potential for vapor encroachment conditions (VECs) in connection with the subject property. This included consideration of chemicals of concern (COC) that may migrate as vapors into the subsurface of the subject property as a result of contaminated soil and groundwater on or near the property.

This screening utilized readily available data sources previously discussed in this Phase I ESA that includes:

- the physical setting of the subject property (Section 2.4),
- standard historical sources for the subject property, adjoining, and surrounding area (Section 3.0),
- known or potentially contaminated sites as identified from information from regulatory agencies and sites on Federal, State, tribal and local databases (Section 4.0), and
- information from the site reconnaissance (Section 6.0) of the subject property and observations of the surrounding properties.

The results of our data collection, reconnaissance, and analysis are tabulated below:

<i>Potential for Vapor Encroachment to Impact the Subject Property</i>	
Area of Concern	Likely or Known VEC to Subject Property
Subject Property Existing Operations or Conditions	None identified that impact the subject property.
Historical Uses of the Subject Property	None identified that impact the subject property.
Adjoining Property Operations or Existing Conditions	None identified that impact the subject property.
Historical Uses of Adjoining Properties or Nearby Properties	None identified that impact the subject property.
Regulatory Review of sites identified on Federal, State, tribal and Local Environmental Databases which were located in the AMSD	None identified that impact the subject property.

8.0 FINDINGS AND CONCLUSIONS

Findings and Opinions

Recognized Environmental Condition

A *REC* refers to the presence of hazardous substances or petroleum products in, on, or at the subject property due to a release to the environment; the likely presence of hazardous substances or petroleum products in, on, or at the subject property due to a release or likely release to the environment; or the presence of hazardous substances or petroleum products in, on, or at the subject property under conditions that pose a material threat of a future release to the environment. The following was identified during the course of this assessment:

- Partner did not identify any RECs during the course of this assessment.

Controlled Recognized Environmental Condition

A *CREC* refers to a REC affecting the subject property that has been addressed to the satisfaction of the applicable regulatory authority or authorities with hazardous substances or petroleum products allowed to remain in place subject to implementation of required controls (for example, activity and use limitations or other property use limitations). The following was identified during the course of this assessment:

- Partner did not identify any CRECs during the course of this assessment.

Historical Recognized Environmental Condition

A *HREC* refers to a previous release of hazardous substances or petroleum products affecting the that has been addressed to the satisfaction of the applicable regulatory authority or authorities and meeting unrestricted use criteria established by the applicable regulatory authority or authorities without subjecting the subject property to any controls (for example, activity and use limitations or other property use limitations). The following was identified during the course of this assessment:

- Partner did not identify any HRECs during the course of this assessment.

Business Environmental Risk

A *BER* is a risk which can have a material environmental or environmentally driven impact on the business associated with the current or planned use of commercial real estate, not necessarily related to those environmental issues required to be investigated in this practice. The following was identified during the course of this assessment:

- Partner did not identify any BERs during the course of this assessment.

Significant Data Gaps

No significant data gaps affecting the ability of the Environmental Professional to identify a REC were encountered during this assessment.

Conclusions and Recommendations

Partner has performed a Phase I Environmental Site Assessment in conformance with the scope and limitations of ASTM Practice E1527-13 and E1527-21 of the property at the northwest corner of Nance Street and North Webster Avenue in the City of Perris, Riverside County, California (the "subject property"). Any exceptions to, or deletions from, this practice are described in Section 1.5 of this report.

This assessment has revealed no evidence of RECs, CRECs, HRECs, or BERs in connection with the subject property. Based on the conclusions of this assessment, Partner recommends no further investigation of the subject property at this time.

9.0 SIGNATURES OF ENVIRONMENTAL PROFESSIONALS

Partner has performed a Phase I Environmental Site Assessment of the property located at the northwest corner of Nance Street and North Webster Avenue in the City of Perris, Riverside County, California in conformance with the scope and limitations of the protocol and the limitations stated earlier in this report. Exceptions to or deletions from this protocol are discussed earlier in this report.

By signing below, Partner declares that, to the best of our professional knowledge and belief, we meet the definition of *Environmental Professional* as defined in §312.10 of 40 CFR §312. Partner has the specific qualifications based on education, training, and experience to assess a *property* of the nature, history, and setting of the subject *property*. Partner has developed and performed all appropriate inquiries in conformance with the standards and practices set forth in 40 CFR Part 312.

Prepared By:



Heather Hodgetts
Senior Scientist

Reviewed by:



Debbie Stott, P.G.
Technical Director

10.0 REFERENCES

Reference Documents

American Society for Testing and Materials, Standard Practice for Environmental Site Assessments: Phase I Environmental Site Assessment Process, ASTM Designation: E1527-13 and E1527-21.

Environmental Risk Information Services (ERIS), Radius Report, May 2022

Federal Emergency Management Agency, Federal Insurance Administration, National Flood Insurance Program, Flood Insurance Map, accessed via internet, May 2022

United States Department of Agriculture, Natural Resources Conservation Service, Web Soil Survey, accessed via the internet, May 2022

United States Environmental Protection Agency, EPA Map of Radon Zones (Document EPA-402-R-93-071), accessed via the internet, May 2022

United States Geological Survey, accessed via the Internet, May 2022

United States Geological Survey Topographic Map, 7.5-minute series, accessed via internet, May 2022

FIGURES

- 1 SITE LOCATION MAP**
- 2 SITE PLAN**
- 3 TOPOGRAPHIC MAP**

APPENDIX A: SITE PHOTOGRAPHS

APPENDIX B: HISTORICAL/REGULATORY DOCUMENTATION

APPENDIX C: REGULATORY DATABASE REPORT

APPENDIX D: QUALIFICATIONS

Appendix 5: LID Infeasibility

LID Technical Infeasibility Analysis (NOT APPLICABLE)

Appendix 6: BMP Design Details

BMP Sizing, Design Details and other Supporting Documentation



Riverside County

SWCT² Stormwater & Water Conservation Tracking Tool

Choose search item from list

33.8673,-117.2476 Zoom: 13.5

WQMP report is only available at zoom level 16 or greater.



- ▶ **Base Data**
- ▼ **Stormwater Data**
 - Hydromodification Susceptibility Mapping
 - 2010 - 303d/TMDL
 - Hydromodification Exemption Areas
 - District Facilities
 - Permit Areas
 - Hydrologic Unit Codes(HUC)
 - Topographic Drainage Boundary
 - Drainage Area Boundaries
 - City Storm Drains
 - WQMP 85% Design Isohyetal Map
 - Rain Gauges
 - Isohyetal Minor Contours
 - Isohyetal Major Contours
 - CRP (Control Release Point)
 - FEMA Floodplain
 - Flood Plain - Other Special Studies
 - As-Built Plans
- ▶ **Groundwater Data**
- ▶ **U.S. Fish and Wildlife Critical Habitat**
- ▶ **WRMSHCP Potential Survey Areas**
- ▶ **SKRHCP**
- ▶ **CVMSHCP Survey Data and Conservation Areas**



Identified Features
 314153082 (Riverside County P...



Santa Ana Watershed - BMP Design Volume, V_{BMP}

(Rev. 10-2011)

Legend:

Required Entries

Calculated Cells

*(Note this worksheet shall **only** be used in conjunction with BMP designs from the **LID BMP Design Handbook**)*

Company Name **Thienes Engineering, Inc.**

Date **7/20/2022**

Designed by **Luis Prado**

Case No

Company Project Number/Name

Nance Street and Webster Avenue (TEI 4108)

BMP Identification

BMP NAME / ID **MWS "A"**

Must match Name/ID used on BMP Design Calculation Sheet

Design Rainfall Depth

85th Percentile, 24-hour Rainfall Depth,
from the Isohyetal Map in Handbook Appendix E

D_{85} = **0.620** inches

Drainage Management Area Tabulation

Insert additional rows if needed to accommodate all DMAs draining to the BMP

DMA Type/ID	DMA Area (square feet)	Post-Project Surface Type	Effective Imperivous Fraction, I_f	DMA Runoff Factor	DMA Areas x Runoff Factor	Design Storm Depth (in)	Design Capture Volume, V_{BMP} (cubic feet)	Proposed Volume on Plans (cubic feet)
A1	174240	Concrete or Asphalt	1	0.89	155422.1			
A2	15681.6	Ornamental Landscaping	0.1	0.11	1732.2			
	189921.6		Total		157154.3	0.62	8119.6	8160

Notes:

Total tributary area = 4.36 acres

Project consists of 0.82 acres of self-treating landscape and some driveway areas sheet flowing offsite.

WETLANDMod VOLUME BASED SIZING SHEET

Project Location

Project Name	Nance Street and Webster Avenue (TEI 4108)
City/Town	Perris
State	CA
Zip Code	92571



Horizontal Flow Biofiltration System

SIZING CALCULATIONS

Impervious Area

	Inputs	Units
BMP Drainage Area <small>(not required - manual entry - not part of formula)</small>	4.36	Acres
Watershed Impervious Ratio <small>(not required - manual entry - not part of formula)</small>		
Runoff Coefficient "C" <small>(not required - manual entry - not part of formula)</small>		

Notes/References

This includes all areas that will contribute runoff to the proposed BMP, including pervious areas, impervious areas, and off-site areas, whether or not they are directly or indirectly connected to the BMP.

Watershed Imperviousness Ratio", is equal to the percent of total impervious area in the "BMP Drainage Area" divided by 100

Water Quality Volume (required)	8120	cubic feet
Design Storm Duration	0	hours

Use sizing procedures provided by state or local agencies to determine the appropriate Water Quality Volume. Intensities and design storms vary widely by region and method.

Varies depending on geographical region. Set at 0 for pump system set up. LA County 3 hours. Call for details.

MWS Sizing

WetlandMod Model Number (from matrix)	MWS-L-4-13	
HGL	3.4	
# Of Units	1	quantity
Discharge Rate (from matrix)	16.27	gallons/minute

Please choose size from "Model Size Matrix" Tab

Treatment Hydraulic Grade Line

Select the number of systems required to treat the water quality volume. Will vary depending on drain down time regulations.

Loading Rate of 0.025 gpm/sq ft or 2.5 in/hr. Field Verified.

Volume Treated During Event

Processed through MWS - Linear	0	cubic feet	16.2656 gals/minute
--------------------------------	---	-------------------	----------------------------

Volume Treated Following Event

MWS Static Capacity (from matrix)	91.94	cubic feet
Volume Needed in Pre-Storage	8028	cubic feet

Set at zero to start. Size pre-storage system to hold this volume

Sizing complete when equal to value of zero.

TOTAL STORMWATER TREATED 8120 **cubic feet**

Note: This amount should be equal to the "Water Quality Volume"

Drain Down Time 62.40 **hours**

Drain down time must be equal to or less than requirement of local jurisdiction. Default 48 hours.

Feel free to fax or email proposed sizing calculations to Modular Wetlands Systems, Inc. for assistance with sizing, compliance, and design.

Phone: 760.433.7640

Fax: 760.433.3176

Email: Info@modularwetlands.com





StormTech
 Detention • Retention • Recharge
 Subsurface Stormwater Management™

MC-3500 Site Calculator

Project Information:
 Project Name: Nance Street and Webster Avenue (TEI 4108)
 Location: Perris, CA
 Date: 20-Jul
 Engineer: Thienes Engineering, Inc.
 StormTech RPM:

System Requirements		
Units	Imperial	
Required Storage Volume	8028	CF
Stone Porosity (Industry Standard = 40%)	40	%
Stone Above Chambers (12 inch min.)	12	inches
Stone Foundation Depth (9 inch min.)	9	inches
Average Cover over Chambers (24 inch min.)	24	inches
Bed size controlled by WIDTH or LENGTH?	WIDTH	
Limiting WIDTH or LENGTH dimension	35	feet
Storage Volume per Chamber	178.9	CF
Storage Volume per End Cap	46.9	CF

System Sizing		
Number of Chambers Required	43	each
Number of End Caps Required	8	each
Bed Size (including perimeter stone)	2,450	square feet
Stone Required (including perimeter stone)	446	tons
Volume of Excavation	499	cubic yards
Non-woven Filter Fabric Required (20% Safety Factor)	820	square yards
Length of Isolator Row	83.6	feet
Non-woven Isolator Row Fabric (20% Safety Factor)	145	square yards
Woven Isolator Row Fabric (20% Safety Factor)	184	square yards
Installed Storage Volume	8,068	cubic feet

Controlled by Width (Rows)		
Maximum Width =	35	feet
3 rows of	11	chambers
1 row of	10	chambers
Maximum Length =	83.60	feet
Maximum Width =	29.92	feet

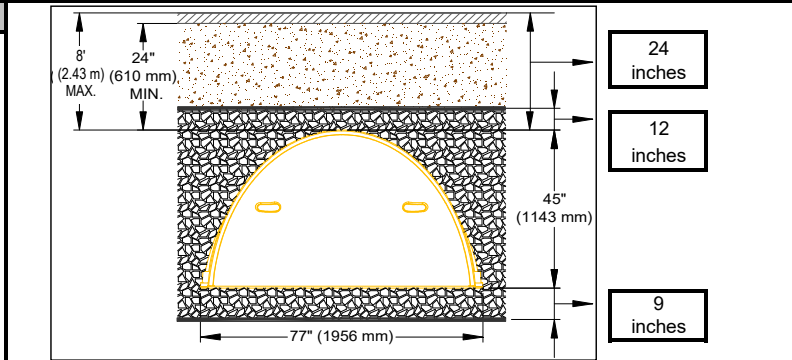

*This represents the estimated material and site work costs (US dollars) for the project. Materials excluded from this estimate are conveyance pipe, pavement design, etc. It is always advisable to seek detailed construction costs from local installers. Please contact STORMTECH at 888-892-2694 for additional cost information.

Appendix 7: Hydromodification

Supporting Detail Relating to Hydrologic Conditions of Concern

Riverside County SWCT² Stormwater & Water Conservation Tracking Tool

TOC Choose search item from list Enter Value Locate Clear

Clear All Metadata

- Base Maps
- Base Data
- Stormwater Data
 - Hydromodification Susceptibility Mapping
 - 2010 - 303d/TMDL
 - Hydromodification Exemption Areas
 - Potentially Not Exempt
 - Potentially Exempt
 - District Facilities
 - District Facilities
 - Proposed District Facilities
 - Basin
 - Detention Basin
 - Retention Basin
 - Debris Basin
 - Dam
 - Levee
 - Spreading Grounds
 - Other
 - Permit Areas
 - Hydrologic Unit Codes (HUC)
 - Topographic Drainage Boundary
 - Drainage Area Boundaries
 - City Storm Drains
 - WQMP 85% Design Isohyetal Map
 - CRP (Contol Release Point)
 - FEMA Flood Plain
 - Flood Plain - Other Special Studies
 - As-Built Plans
 - Groundwater Data
 - U.S. Fish and Wildlife Critical Habitat
 - WRMSHCP Potential Survey Areas
 - SKRHCP
 - CVMSHCP Survey Data and Conservation Areas

1 KM 4000ft

Identify Features
Click on map to view data.

06065C_06065C_184 (Fema Flood Zones)

OBJECTID_1	380
OBJECTID	368
DFIRM_ID	06065C
VERSION_ID	1.1.1.0
FLD_AR_ID	06065C_06065C_184
STUDY_TYP	NP
ZONE_SUBTY	0.2 PCT ANNUAL CHANCE
SFHA_TF	F
STATIC_BFE	-9999
V_DATUM	
DEPTH	-9999
LEN_UNIT	
VELOCITY	-9999

Appendix 8: Source Control

Pollutant Sources/Source Control Checklist

Appendix 9: O&M

Operation and Maintenance Plan and Documentation of Finance, Maintenance and Recording Mechanisms

Appendix 10: Educational Materials

BMP Fact Sheets, Maintenance Guidelines and Other End-User BMP Information