

LEGEND

- PROPERTY LINE
- - - CENTER LINE
- SETBACK
- LIMIT OF WORK
- FW --- PROPOSED FIRE WATER LINE
- [Pattern] LANDSCAPE/PLANTER AREA
- [Pattern] PRIVATE FIRE LANE - MIN CAPACITY GROSS VEHICLE WEIGHT OF 70,000 LBS

FIRE DEPARTMENT ACCESS & WATER NOTES

- INSPECTION REQUIREMENTS**
- PERRIS SITE INSPECTIONS ARE REQUIRED FOR THIS PROJECT. PLEASE SCHEDULE ALL FIELD INSPECTIONS AT LEAST 48 HOURS IN ADVANCE. INSPECTIONS CANCELED AFTER 1 P.M. ON THE DAY BEFORE THE SCHEDULED DATE WILL BE SUBJECT TO A RE-INSPECTION FEE. CALL (951) 443-1029 TO SCHEDULE AN INSPECTION.
 - A LUMBER DROP INSPECTION SHALL BE PERFORMED PRIOR TO BRINGING COMBUSTIBLE MATERIALS (OR COMBUSTIBLE FIXTURES AND FINISHES FOR STRUCTURES OF NON-COMBUSTIBLE CONSTRUCTION). ALL-WEATHER ACCESS ROADS CAPABLE OF SUPPORTING 68,000 LBS., TOPPED WITH ASPHALT, CONCRETE, OR EQUIVALENT SHALL BE IN PLACE AND HYDRANTS OPERATIONAL AT TIME OF LUMBER DROP INSPECTION.
 - FOR PROJECTS WITH FUEL MODIFICATION, A VEGETATION CLEARANCE INSPECTION IS REQUIRED PRIOR TO A LUMBER DROP INSPECTION. USE THE FUEL MODIFICATION PLAN SERVICE REQUEST NUMBER TO SCHEDULE THE VEGETATION CLEARANCE INSPECTION.
 - PHASED INSTALLATION OF FIRE ACCESS ROADS REQUIRES ADDITIONAL INSPECTIONS NOT COVERED BY THE FEES PAID AT PLAN SUBMITTAL. CONTACT (951) 443-1029 TO ARRANGE FOR ADDITIONAL INSPECTIONS THAT MAY BE NEEDED AND ANY FEES THAT MAY BE DUE.
 - AN ORIGINAL APPROVED, SIGNED, WET-STAMPED PERRIS FIRE ACCESS & WATER PLAN SHALL BE AVAILABLE ON-SITE AT TIME OF INSPECTION.
 - ACCESS ROADS AND HYDRANTS SHALL BE MAINTAINED AND REMAIN CLEAR OF OBSTRUCTIONS AT ALL TIMES DURING AND AFTER CONSTRUCTION. AREAS WHERE PARKING IS NOT PERMITTED SHALL BE CLEARLY IDENTIFIED AT ALL TIMES. OBSTRUCTION OF FIRE LANES AND HYDRANTS MAY RESULT IN CANCELLATION OR SUSPENSION OF INSPECTIONS.
 - TEMPORARY FUEL TANKS OF 60 OR MORE GALLONS SHALL BE REVIEWED, INSPECTED, AND PERMITTED BY THE OFFICE OF THE FIRE MARSHAL, CITY OF PERRIS PRIOR TO USE.
 - THE PROJECT ADDRESS SHALL BE CLEARLY POSTED AND VISIBLE FROM THE PUBLIC ROAD DURING CONSTRUCTION.
 - ALL GATES IN CONSTRUCTION FENCING SHALL BE EQUIPPED WITH EITHER A KNOX OR BREAKAWAY PADLOCK.
 - BUILDINGS OF FOUR OR MORE STORIES SHALL BE PROVIDED WITH STAIRS AND A STANDPIPE BEFORE REACHING 40 FEET IN HEIGHT.
- GENERAL REQUIREMENTS**
- FIRE LANE WIDTHS SHALL BE MEASURED FROM TOP FACE OF THE CURB TO TOP FACE OF THE CURB FOR FIRE LANES WITH STANDARD CURBS AND GUTTERS AND FROM FLOW-LINE TO FLOW-LINE FOR FIRE LANES WITH MODIFIED CURB DESIGNS (E.G., ROLLED, RAMPED, ETC.). THE DEVELOPER IS RESPONSIBLE TO VERIFY THAT ALL APPROVED PUBLIC WORKS OR GRADING DEPARTMENT STREET IMPROVEMENT PLANS OR PRECISE GRADING PLANS CONFORM TO THE MINIMUM STREET WIDTH MEASUREMENTS PER THE APPROVED PERRIS FIRE DEPARTMENT ACCESS & WATER PLAN AND STANDARDS IDENTIFIED IN PERRIS FIRE DEPARTMENT ACCESS & WATER GUIDELINE FOR ALL PORTIONS OF THE FIRE ACCESS ROADS.
 - PERMANENT, TEMPORARY, AND PHASED EMERGENCY ACCESS ROADS SHALL BE DESIGNED AND MAINTAINED TO SUPPORT AN IMPOSED LOAD OF 68,000 LBS. AND SURFACED TO PROVIDE ALL-WEATHER DRIVING CAPABILITIES.
 - FIRE LANE SIGNS AND RED CURBS SHALL MEET THE SPECIFICATIONS SHOWN IN PERRIS FIRE DEPARTMENT ACCESS & WATER GUIDELINE AND SHALL BE INSTALLED AS DESCRIBED THEREIN. ADDITIONAL FIRE LANE MARKINGS MAY BE REQUIRED AT THE TIME OF INSPECTION DEPENDING ON FIELD CONDITIONS.
 - ALL FIRE HYDRANTS SHALL HAVE A 'BLUE REFLECTIVE PAVEMENT MARKER' INDICATING THEIR LOCATION PER THE PERRIS STANDARD. ON PRIVATE PROPERTY MARKERS ARE TO BE MAINTAINED IN GOOD CONDITION BY THE PROPERTY OWNER.
 - ADDRESS NUMBERS SHALL BE LOCATED AND BE OF A COLOR AND SIZE SO AS TO BE PLAINLY VISIBLE AND LEGIBLE FROM THE ROADWAY FROM WHICH THE BUILDING IS ADDRESSED IN ACCORDANCE WITH PERRIS FIRE DEPARTMENT ACCESS & WATER GUIDELINE.
 - ACCESS GATES SHALL BE APPROVED PRIOR TO INSTALLATION AND SHALL BE IN COMPLIANCE WITH CHAPTER 5 OF THE CFC AND PERRIS FIRE DEPARTMENT ACCESS & WATER GUIDELINE.
 - APPROVED ACCESS WALKWAYS SHALL BE PROVIDED TO ALL REQUIRED OPENINGS AND ALL RESCUE WINDOWS.
 - VEGETATION SHALL BE SELECTED AND MAINTAINED IN SUCH A MANNER AS TO ALLOW IMMEDIATE ACCESS TO ALL HYDRANTS, VALVES, FIRE DEPARTMENT CONNECTIONS, PULL STATIONS, EXTINGUISHERS, SPRINKLER RISERS, ALARM CONTROL PANELS, RESCUE WINDOWS, AND OTHER DEVICES OR AREAS USED FOR FIREFIGHTING PURPOSES. VEGETATION OR BUILDING FEATURES SHALL NOT OBSTRUCT ADDRESS NUMBERS OR INHIBIT THE FUNCTIONING OF ALARM BELLS, HORNS, OR STROBES.
 - DUMPSTERS AND TRASH CONTAINERS LARGER THAN 1.5 CUBIC YARDS SHALL NOT BE STORED IN BUILDINGS OR PLACED WITHIN 5 FEET OF COMBUSTIBLE WALLS, OPENINGS OR COMBUSTIBLE ROOF EAVE LINES UNLESS PROTECTED BY AN APPROVED SPRINKLER SYSTEM.
 - ANY FUTURE MODIFICATION TO THE APPROVED FIRE DEPARTMENT ACCESS & WATER PLAN OR APPROVED SITE PLAN, INCLUDING BUT NOT LIMITED TO ROAD WIDTH, GRADE, SPEED HUMPS, TURNING RADII, GATES OR OTHER OBSTRUCTIONS, SHALL REQUIRE REVIEW, INSPECTION, AND APPROVAL BY THE OFFICE OF THE FIRE MARSHAL, CITY OF PERRIS.
 - APPROVAL OF THIS PLAN SHALL NOT BE CONSTRUED AS APPROVAL OF ANY INFORMATION OR PROJECT CONDITIONS OTHER THAN THOSE ITEMS AND REQUIREMENTS IDENTIFIED IN PERRIS FIRE DEPARTMENT ACCESS & WATER GUIDELINE AND RELATED PORTIONS OF THE CFC AND CBC. THIS PROJECT MAY BE SUBJECT TO ADDITIONAL REQUIREMENTS NOT STATED HEREIN UPON EXAMINATION OF ACTUAL SITE AND PROJECT CONDITIONS OR DISCLOSURE OF ADDITIONAL INFORMATION.

SITE DATA

APN'S: 329-250-011 AND 329-250-012

GROSS PARCEL	±14.4	ACRES
PROPOSED PARCEL	±13.4	ACRES
DISTURBED	±13.75	ACRES
TOTAL PERVIOUS	±4.39	ACRES
TOTAL IMPERVIOUS (INCLUDING BUILDING)	±9.36	ACRES

TOTAL GROSS FLOOR AREA: 22,432 SF

BENCH MARK:
 COUNTY OF RIVERSIDE BENCHMARK "M 21-1 RESET", 373 FEET EAST ALONG ETHANAC ROAD FROM THE INTERSECTION OF ETHANAC ROAD AND THE SOUTHBOUND LANES OF HIGHWAY 395. 150 FEET SOUTH OF ETHANAC ROAD, 50 FEET SOUTHEAST OF THE NORTHEAST CORNER OF A 6 FOOT CHAIN LINK RIGHT-OF-WAY FENCE, 1 FOOT NORTHEAST OF AN ANGLE-POINT IN THE RIGHT-OF-WAY FENCE, 2 FEET NORTH OF A MARKER POST, A BRASS DISK STAMPED "M-21-1 RESET" SET IN THE TOP OF A CONCRETE POST 3 INCHES ABOVE GROUND. EL = 1421.891 NGVD 29 (5/85)

MARK	BY	DATE	REVISIONS	APPR	DATE

CITY OF PERRIS

APPROVED BY: _____
 CONTRACT CITY ENGINEER DATE _____

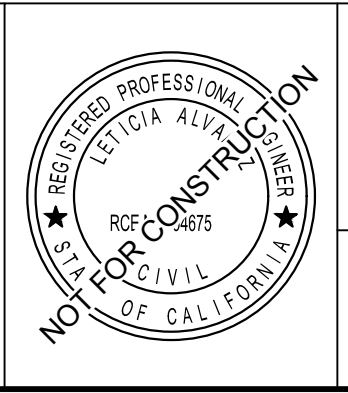

Kimley»Horn

3801 UNIVERSITY AVENUE, SUITE 300, RIVERSIDE, CA 92501
 PHONE: 951-543-9868

PREPARED BY: Leticia Alvarez
 DATE: 9/17/2024
 R.C.E. 94675

FIRE ACCESS EXHIBIT

ETHANAC TRAVEL CENTER
 ETHANAC ROAD AND TRUMBLE ROAD
 APN: 329-250-011 & 329-250-012

PROJECT NUMBER: 095428010
 FILE NO.:

SHEET NO. 1
 OF 1 SHTS

811 DIAL TOLL FREE 811

Know what's below. Call before you dig.

AT LEAST TWO DAYS BEFORE YOU DIG

UNDERGROUND SERVICE ALERT OF SOUTHERN CALIFORNIA

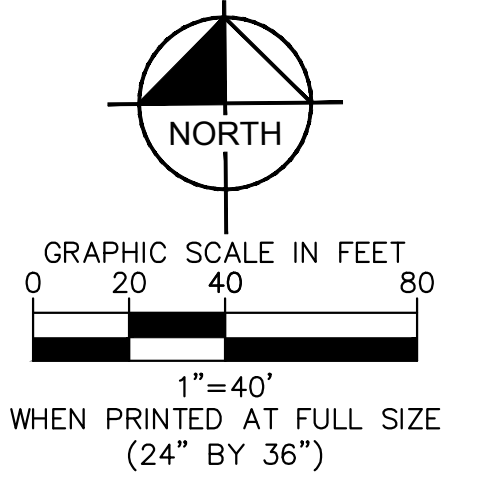

This document, together with the concepts and design presented herein, as an instrument of service, is intended only for the specific purpose and client for which it was prepared. Reuse of and improper reliance on this document without written authorization and adaptation by Kimley-Horn and Associates, Inc. shall be without liability to Kimley-Horn and Associates, Inc.