



2 Executive Circle
Suite 250
Irvine, CA 92614
949.825.6175 T
949.825.5939 F
www.llgengineers.com

Pasadena
Irvine
San Diego

February 1, 2024

Mr. Joel Kirschenstein
Sage Realty Group, Inc.
2945 Townsgate Road, Suite 200
Westlake Village, CA 91361

LLG Reference: 2.23.4685.1

Subject: **Focused Traffic Impact Analysis for the March Plaza Project**
Perris, California

Dear Mr. Kirschenstein:

Linscott, Law & Greenspan, Engineers (LLG) is pleased to submit this Focused Traffic Impact Analysis for the proposed March Plaza Project (herein referred to as “Project”), generally located on the northwest corner of the intersection of Perris Boulevard and Harley Knox Boulevard in the City of Perris, California. The Project site is currently vacant and is located within the Perris Valley Commerce Center Specific Plan (PVCC SP). **Figure 1** presents a Vicinity Map, which illustrates the general location of the project site and depicts the surrounding street system and **Figure 2** presents an existing site aerial.

The Focused Traffic Impact Analysis for the proposed Project will satisfy the *City of Perris LOS Standards and Traffic Criteria for Traffic Studies* and will focus to the two (2) existing Project driveways located along Harley Knox Boulevard. The Scope of Work for this focused traffic impact analysis, which is included in **Appendix A**, was developed in conjunction with City of Perris staff. Included in this focused traffic impact analysis are the following:

- 1) Existing traffic counts,
- 2) Estimated Project traffic generation/distribution/assignment,
- 3) Estimated cumulative project traffic generation/distribution/assignment,
- 4) AM and PM peak hour analyses for existing traffic conditions,
- 5) AM and PM peak hour analyses for Year 2026 traffic conditions without and with the proposed Project,
- 6) Recommended Improvements (if any),
- 7) Site access evaluation, and
- 8) Vehicle Miles Traveled (VMT) screening assessment.

David S. Shender, PE
John A. Boorman, PE
Richard E. Barretto, PE
Keil D. Maberry, PE
KC Yellapu, PE
Dave Roseman, PE
Shankar Ramakrishnan, PE

Our method of analysis, findings, and recommendations are detailed in the following sections of this letter report.

PROJECT DESCRIPTION

Figure 3 presents the proposed site plan for the proposed Project, prepared by PK Architecture. As shown in *Figure 3*, the proposed Project will consist of 66,686 square feet (SF) of industrial uses within three buildings. Building A is 23,881 SF, Building B is 20,340 SF and Building C is 22,465 SF.

Access to the Project site will be provided via one (1) existing right-turn in/right-turn out only driveway (Project Driveway No. 1) and via one (1) existing left-turn in/right-turn in/right-turn out only driveway (Project Driveway No. 2) located along Harley Knox Boulevard. Additional access to the Project site will also be provided via two (2) existing right-turn in/right-turn out only driveways located along Perris Boulevard. It should be noted that passenger cars and trucks associated with the proposed Project will utilize all driveways on Harley Knox Boulevard and/or Perris Boulevard to access the site.

EXISTING TRAFFIC CONDITIONS

Existing Lane Geometrics

Figure 4 presents an inventory of the existing roadway conditions for the two (2) existing Project driveways. This figure identifies the number of travel lanes for key arterials, as well as intersection configurations and controls for the key area study intersections.

Existing Public Transit

The Riverside Transit Agency operates Bus Route 19 within the vicinity of the project site (i.e. located east of the proposed project site). Bus Route 19 operates on weekdays along Perris Boulevard between the Moreno Valley Mall and the Perris Station Transit Center. During the AM and PM peak periods, Route 19 has approximate headways that range from 15 minutes to 60 minutes in the northbound and southbound directions.

Existing Traffic Volumes

AM peak hour and PM peak hour traffic counts were collected by Transportation Studies, Inc. on January 9, 2024 at the two (2) existing Project driveways in order to develop the baseline peak hour traffic volume data for the intersection analysis. *Figure 5* illustrates the existing AM and PM peak hour traffic volumes at the two (2)



existing Project driveways. The existing AM and PM peak hour traffic volumes illustrated in *Figure 5* are comprised of passenger vehicles, large 2-axle trucks, 3-axle trucks and 4+-axle trucks. The truck traffic turning movements were converted to passenger car equivalents (P.C.E.'s) using City of Perris approved factors (i.e. P.C.E. factor of 1.5, 2.0 and 3.0 for large 2-axle trucks, 3-axle trucks and 4+-axle trucks, respectively).

Appendix B contains the detailed peak hour traffic count sheets for the two (2) existing Project driveways.

LEVEL OF SERVICE METHODOLOGY

In conformance with City of Perris requirements, AM and PM peak hour operating conditions for the unsignalized intersections were evaluated using the *Highway Capacity Manual 7th Edition* (HCM 7) methodology.

Highway Capacity Manual (HCM) Method of Analysis (Unsignalized Intersections)

The HCM 7 unsignalized methodology for stop-controlled intersections was utilized for the analysis of the unsignalized intersections. This methodology estimates the average control delay for each of the subject movements and determines the level of service for each movement. For all-way stop controlled intersections, the overall average control delay measured in seconds per vehicle, and level of service is then calculated for the entire intersection. For one-way and two-way stop-controlled (minor street stop-controlled) intersections, this methodology estimates the worst side street delay, measured in seconds per vehicle and determines the level of service for that approach. The HCM control delay value translates to a LOS estimate, which is a relative measure of the intersection performance. The six qualitative categories of Level of Service have been defined along with the corresponding HCM control delay value range, as shown in *Table 1*.

LEVEL OF SERVICE STANDARDS AND IMPACT CRITERIA

City of Perris

Based on the *City of Perris LOS Standards and Traffic Criteria for Traffic Studies*, the LOS standards should maintain the following target Levels of Service:

- LOS "D" along all City maintained roads (including intersections) and LOS "D" along I-215 and SR-74 (including intersections with local streets and roads). An exception to the local road standard is LOS "E", at intersections of any Arterials



and Expressways with SR-74, the Ramona-Cajalco Expressway or at 1-215 Freeway ramps.

- LOS "E" may be allowed within the boundaries of the Downtown Specific Plan Area to the extent that it would support transit-oriented development and walkable communities. Increased congestion in this area will facilitate an increase in transit ridership and encourage development of a complementary mix of land uses within a comfortable walking distance from light rail stations.

Based on the above, LOS D is the level of service standard for the two (2) existing Project driveways.

To determine whether the addition of project-generated trip results in a project traffic impact, and thus requires improvements, the analysis shall evaluate traffic impacts of the project based on the following criteria:

- A project-related traffic impact is considered direct when a study intersection operates at an acceptable Level of Service for existing conditions (without the project) and the addition of 50 or more AM or PM peak hour project trips causes the intersection delay to increase by 2 seconds or more and causes the intersection to operate at an unacceptable Level of Service for existing plus project conditions.
- A project-related traffic impact is considered direct when a study intersection operates at an unacceptable Level of Service for existing conditions (without the project) and the addition of 50 or more AM or PM peak hour project trips causes the intersection delay to increase by 2 seconds or more.
- A cumulative impact is considered direct when a study intersection is forecast to operate at an acceptable Level of Service without the project and with the addition of 50 or more AM or PM peak hour project trips causes the intersection delay to increase by 2 seconds or more and causes the intersection to operate at unacceptable Level of Service.
- A cumulative impact is considered an indirect traffic impact when a study intersection is forecast to operate at an unacceptable Level of Service with the addition of cumulative/background traffic and the project contributes 50 or more AM or PM peak hour project trips and causes the intersection delay to increase by 2 seconds or more.

PROJECT TRAFFIC CHARACTERISTICS

Project Trip Generation

Traffic generation is expressed in vehicle trip ends, defined as one-way vehicular movements, either entering or exiting the generating land use. Generation equations and/or rates used in the traffic forecasting procedure are typically found in the 11th Edition of *Trip Generation*, published by the Institute of Transportation Engineers (ITE) [Washington D.C., 2021].

Table 2 summarizes the trip generation rates used in forecasting the vehicular trips generated by the proposed Project and presents the forecast daily and peak hour project traffic volumes for a “typical” weekday. As shown in the upper portion of **Table 2**, the trip generation potential for the proposed Project was estimated using ITE Land Use Code 130: Industrial Park trip rates. Consistent with standard traffic engineering practice for land uses with potential truck traffic, passenger car equivalent (PCE) factors have been utilized for the truck components of the proposed Project. Per discussions with City of Perris staff, a PCE factor of 1.5, 2.0, and 3.0 has been applied to large 2-axle, 3-axle, and 4+-axle trucks, respectively.

As shown at the bottom of **Table 2**, the proposed Project is expected to generate 284 daily PCE trips, with 27 PCE trips (22 inbound, 5 outbound) produced in the AM peak hour and 27 PCE trips (6 inbound, 21 outbound) produced in the PM peak hour on a “typical” weekday.

Trip Distribution and Assignment

Figure 6 presents the traffic distribution pattern for the proposed Project. Project traffic volumes both entering and exiting the site have been distributed and assigned to the adjacent street system based on the following considerations:

- the site's proximity to major traffic carriers and regional access routes,
- expected localized traffic flow patterns based on adjacent street channelization, and presence of traffic signals,
- I-215 Freeway access, and
- ingress/egress availability at the Project site.

The anticipated AM and PM peak hour traffic volumes associated with proposed Project are presented in **Figure 7**. The traffic volume assignments presented in **Figure 7** reflect the traffic distribution characteristics shown in **Figure 6** and the traffic generation forecast presented in **Table 2** (PCE trips).

FUTURE YEAR 2026 TRAFFIC CONDITIONS

Year 2026 Ambient Traffic Growth

Horizon year, background traffic growth estimates have been calculated using an ambient growth factor. The ambient traffic growth factor is intended to include unknown and future cumulative projects in the study area, as well as account for regular growth in traffic volumes due to the development of projects outside the study area. The future growth in traffic volumes has been calculated at three percent (3.0%) per year. Applied to existing Year 2024 traffic volumes results in a six percent (6.0%) growth in existing volumes to horizon Year 2026.

Cumulative Projects Traffic Characteristics

In order to make a realistic estimate of future on-street conditions prior to implementation of the proposed Project, the status of other known development projects (cumulative projects) has been researched at the City of Perris. With this information, the potential impact of the proposed Project can be evaluated within the context of the cumulative impact of all ongoing development. As directed by City of Perris staff, the sixty-three (63) cumulative projects identified in the *Transportation Impact Analysis Report for the 255 E. Nance Street Warehouse Project*, prepared by Dudek (dated February 2023) were included. The 255 E. Nance Street Warehouse Project and the two entitled fast-food restaurant with drive-through buildings (i.e. Building D and Building F) to be located north of the existing 7-Eleven were also included. These sixty-six (66) cumulative projects have been included as part of the cumulative background setting.

Table 3 provides the location and a brief description for each of the sixty-six (66) cumulative projects. **Figure 8** graphically illustrates the location of cumulative projects #64, #65 and #66. **Appendix C** contains a map indicating the location of cumulative projects #1 through #63 as well as a trip generation table for cumulative projects #1 through #63, which includes the sizes and land uses of the projects. Both the map and the table are from the *Transportation Impact Analysis Report for the 255 E. Nance Street Warehouse Project*, prepared by Dudek (dated February 2023). These cumulative projects are expected to generate vehicular traffic, which may affect the operating conditions of the key study intersections.

Table 4 presents the development totals and resultant trip generation for the cumulative projects. As shown in **Table 4**, the cumulative projects are forecast to generate a total of 65,922 daily trips, with 4,729 trips (2,712 inbound and 2,017 outbound) forecast during the AM peak hour and 5,868 trips (2,517 inbound and 3,351 outbound) forecast during the PM peak hour.



The anticipated AM peak hour and PM peak hour traffic volumes associated with the sixty-six (66) cumulative projects are presented in **Figure 9**.

Year 2026 Traffic Volumes

Figure 10 illustrates the Year 2026 Cumulative AM peak hour and PM peak hour traffic volumes. **Figure 11** illustrates the Year 2026 Cumulative Plus Project AM peak hour and PM peak hour traffic volumes.

YEAR 2026 CUMULATIVE PLUS PROJECT CAPACITY ANALYSIS

Table 5 summarizes the peak hour level of service results at the two (2) existing Project driveways for Year 2026 Cumulative Plus Project traffic conditions. Review of column (1) of **Table 5** indicates that the two (2) existing Project driveways currently operate at acceptable LOS B during the AM and PM peak hours. Review of column (2) of **Table 5** indicates that the two (2) existing Project driveways are forecast to continue to operate in the Year 2026 at acceptable LOS B during the AM and PM peak hours. Review of columns (3) and (4) of **Table 5** indicates that traffic associated with proposed Project ***will not*** impact either of the two (2) existing Project driveways when compared to the LOS standards and significant impact criteria specified in this letter report. The two (2) existing Project driveways currently operate and are forecast to continue to operate in the Year 2026 at an acceptable LOS during the AM and PM peak hours with the addition of Project generated traffic to existing traffic, ambient growth traffic and cumulative traffic.

Appendix D contains the existing, Year 2026 Cumulative, and Year 2026 Cumulative plus Project AM peak hour and PM peak hour HCM/LOS calculation worksheets for the two (2) existing Project driveways.

RECOMMENDED IMPROVEMENTS

The results of the “Year 2026 Cumulative Plus Project” intersection capacity analyses presented previously in **Table 5** indicates that the proposed Project ***will not*** impact either of the two (2) existing Project driveways. Given that there are no project impacts, no improvements are required under Year 2026 Cumulative Plus Project traffic conditions.



PROJECT DRIVEWAY QUEUING EVALUATION

To address stacking/storage lengths at the two (2) existing Project driveways, a queuing evaluation was prepared based on projected Year 2026 Cumulative Plus Project traffic volumes. As requested by City of Perris staff, the storage provided for the southbound right-turn lane at Project Driveway No. 1 and the storage provided for the southbound right-turn lane and eastbound left-turn lane at Project Driveway No. 2 was evaluated. **Table 6** presents the Project driveways queuing analysis results for Year 2026 Cumulative Plus Project traffic conditions. As shown in **Table 6**, adequate storage is provided to accommodate the forecast 95th percentile queues under Year 2026 Cumulative Plus Project traffic conditions for the two (2) existing Project driveways.

As requested by City staff, the need for a westbound right-turn deceleration lane at existing Project Driveway No. 2 was evaluated. Per the *Highway Capacity Manual 2000*, “an exclusive right-turn lane should be considered if the right-turn volume exceeds 300 veh/h and the adjacent mainline volume exceeds 300 veh/h/ln.” Based on review of the forecast peak hour right-turning volumes (i.e. less than 300 right-turns) and the peak hour level of service calculations, a westbound deceleration lane is not needed at existing Project Driveway No. 2.

It should be noted that the two existing driveways along Harley Knox Boulevard are spaced approximately 350 feet apart (center-to-center). Although the spacing does not satisfy the specific requirements of the Perris Valley Commerce Center Specific Plan (PVCC SP), 350 feet is adequate, given that outbound movements at both existing driveways are restricted to right-turns out only.

INTERNAL CIRCULATION EVALUATION

The on-site circulation layout of the proposed Project as illustrated in *Figure 3* on an overall basis is adequate. Curb return radii have been confirmed and are generally adequate for small service/delivery (FedEx, UPS) vehicles, trash trucks and trucks.

SB 743 VEHICLE MILES TRAVELED (VMT) ASSESSMENT

On December 28, 2018, the California Natural Resources Agency adopted revised CEQA Guidelines. Among the changes to the guidelines was the removal of vehicle delay and LOS from consideration for transportation impacts under CEQA. With the adopted guidelines, transportation impacts are to be evaluated based on a project's

effect on vehicle miles traveled. Lead agencies are allowed to continue using their current impact criteria, or to opt into the revised transportation guidelines.

Under the VMT methodology, screening is used to determine if a project will be required to conduct a detailed VMT analysis. The following section discusses the various screening methods outlined in the *City of Perris Transportation Impact Analysis Guidelines for CEQA (dated May 12, 2020)*, hereinafter referred to “VMT Guidelines”, and outlines whether the Project will screen-out, either in its entirety, or partially based on individual land uses. Based on the VMT Guidelines, the first step in evaluating a land use project’s VMT impact is to perform an initial screening assessment utilizing the City of Perris VMT Scoping Form for Land Use Projects, hereinafter referred to as “VMT Scoping Form”. The VMT Scoping Form provides a tool for streamlining the VMT analysis process and the automated spreadsheet provided by the Planning Department was utilized and contained in **Appendix E**. A project is presumed to have a less than significant impact on VMT if the project satisfies at least one of the VMT screening criteria. The VMT screening criteria and their applicability to the Project are discussed below.

A. Is the Project 100% Affordable Housing?

The *VMT Guidelines* state:

“If a project consists of 100% affordable housing, then the presumption can be made that it will have a less than significant impact on VMT. According to sources provided by OPR, affordable housing projects typically generate lower VMT than market-rate housing and a project consisting of a high percentage of affordable housing may be a basis for the lead agency to find a less than significant impact on VMT. Furthermore, a project which includes any affordable residential units may factor in the effect of the affordability on VMT into the assessment of VMT generated by those units”

- Based on the above, the VMT Guidelines and the VMT Scoping Form, the proposed Project will not screen out under this criterion since it is not 100% affordable housing.

B. Is the Project within One Half (½) Mile of Qualifying Transit?

The *VMT Guidelines* state:

“CEQA Guideline Section 15064.3, subdivision (b)(1), states that lead agencies generally should presume that certain projects (including residential, retail, and office projects, as well as projects that are a mix of

these uses) proposed within one half (1/2) mile of an existing major transit stop or an existing stop along a high quality transit corridor will have a less than significant impact on VMT.

Not all projects located near qualifying transit are presumed to have a less than significant impact. The presumption of less than significant does not apply if the project.

- *Includes more parking for use by residents, customers, or employees of the project than required by the jurisdiction (if the jurisdiction requires the project to supply parking);*
 - *Is inconsistent with the applicable Sustainable Communities Strategy (as determined by the lead agency, with input from the Metropolitan Planning Organization); or*
 - *Replaces affordable residential units with a smaller number of moderate or high-income residential units.”*
- Based on the above, the VMT Guidelines and the VMT Scoping Form, the proposed Project will screen out under this criterion since it is located within one half (1/2) mile of qualifying transit. It should be noted that the project will not provide more parking than required by the City, is consistent with the SCS and does not replace affordable housing.

C. Is the Project a Local Serving Land Use?

The *VMT Guidelines* state:

“Local serving land uses provide more opportunities for residents and employees to shop, dine and obtain services closer to home and work. Local serving uses can also include community resources that may otherwise be located outside of the city or local area.

By improving destination proximity, local serving uses lead to shortened trip lengths and reduced VMT. Therefore, local serving uses may be presumed to have a less than significant impact on VMT. The following list contains the eligible local serving uses in the City of Perris:

- *Local Serving Retail < 50 TSF*
- *Education/Institutional*
- *Municipal/Public Services*

- Based on the above, the VMT Guidelines and the VMT Scoping Form, the proposed Project will not screen out under this criterion since it is not local serving retail.

D. Is the Project in a Low VMT Area?

The *VMT Guidelines* state:

“Projects that locate in areas with low VMT, and that incorporate similar features (i.e., land use type, access to the circulation network, etc.), will tend to exhibit similarly low VMT. If a project is located in a Traffic Analysis Zone (TAZ) with VMT per capita or VMT per employee that is less than or equal to the Citywide average, then the project is considered to be located in a low VMT area and can be presumed to have a less than significant impact on VMT.”

- Based on the above, the VMT Guidelines and the VMT Scoping Form (with use of the current RIVCOM WRCOG Screening Tool), the proposed Project will screen out under this criterion since it is located in a low VMT area. As shown in *Appendix E*, the Project (TAZ 1873) VMT/Employee is 16.9 which is lower than the Citywide VMT/Employee threshold of 17.1.

E. Are the Project’s Net Daily Trips less than 500 ADT?

The *VMT Guidelines* state:

“Projects that generate less than 500 average daily trips (ADT) would not cause a substantial increase in the total citywide or regional VMT and are therefore presumed to have a less than significant impact on VMT.”

- Based on the above, the VMT Guidelines and the VMT Scoping Form, the proposed Project will screen out under this criterion since the Project generates 284 gross daily trips, which is lower than the 500 net daily trips threshold.

Consistent with the *City of Perris VMT Guidelines*, the *City of Perris VMT Scoping Forms* and based on the VMT screening methodology and findings outlined in this section, the proposed Project satisfies at least three of the VMT screening criteria (i.e. located within one half (½) mile of qualifying transit, located in a low VMT area and the Project generates less than 500 net daily trips) and thus would screen out. Therefore, in accordance with the City of Perris VMT Guidelines, the proposed Project is exempt from the preparation of any further VMT analysis and may be presumed to have a less than significant CEQA-related transportation impact.

CONCLUSION

The results of the Focused Traffic Impact Analysis indicate that the proposed March Plaza Project will not impact the existing surrounding roadway network. The two (2) existing Project driveways are forecast to operate in the Year 2026 at acceptable levels of service during the AM peak hour and PM peak hour. In addition, queues are expected to be no more than one project vehicle entering or exiting the site. As such, project access will be adequate. Lastly, the Project can be screened from further VMT analysis and can be presumed to have a less than significant impact on VMT, per the City's guidelines.

We appreciate the opportunity to provide this Focused Traffic Impact Analysis. Should you have any questions, please call us at (949) 825-6175.

Sincerely,
Linscott, Law & Greenspan, Engineers



Daniel A. Kloos, P.E.
Associate Principal
California Registration: TR 2200



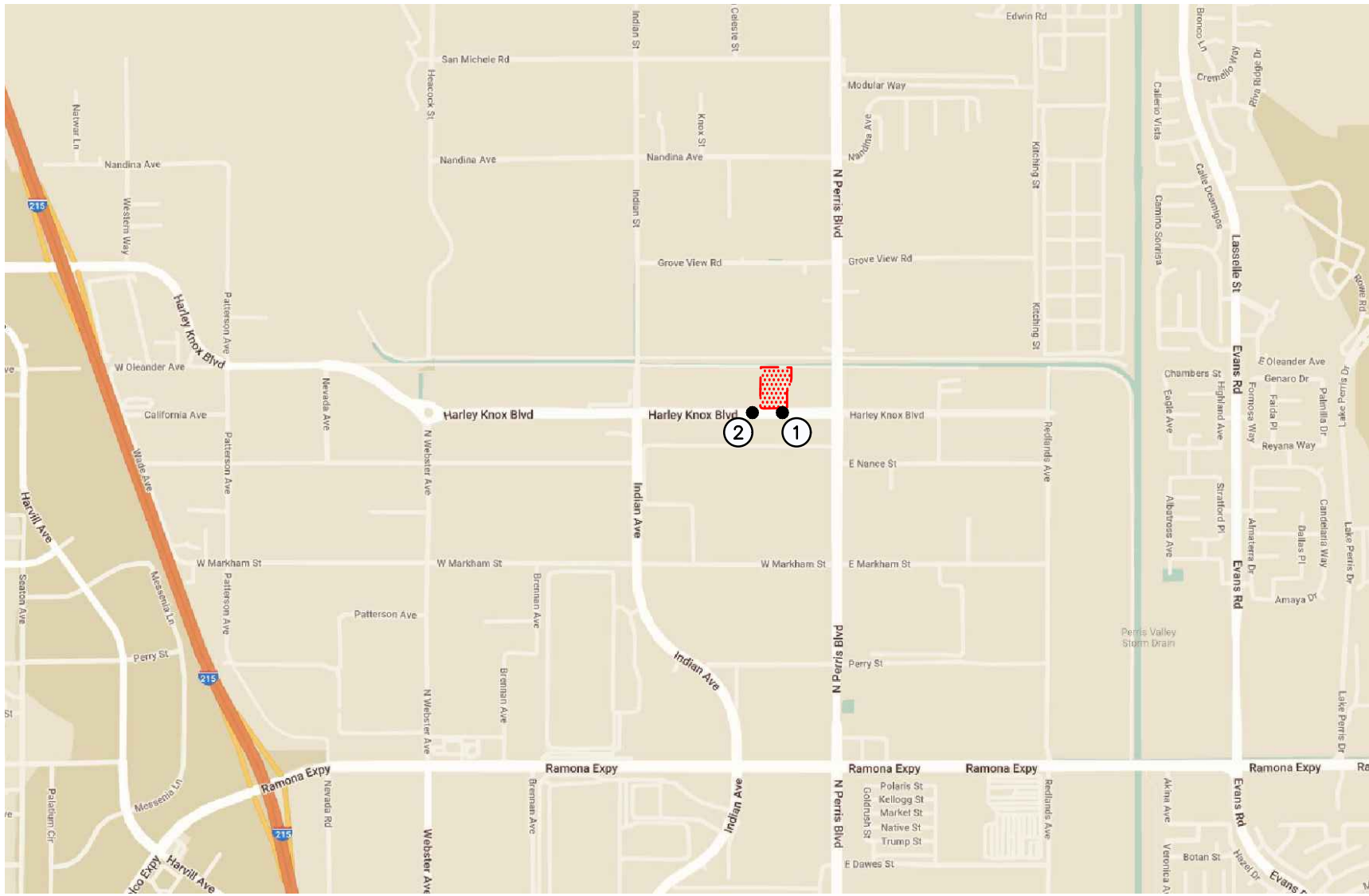

n:\4600\2234685 - march plaza industrial project, perris\dwg\4685 f-1.dwg LDP 08:12:56 01-31-2024 aguilera



NO SCALE

SOURCE: GOOGLE

KEY

 = STUDY INTERSECTION

 = PROJECT SITE

FIGURE 1

VICINITY MAP
MARCH PLAZA, PERRIS



n:\4600\2234685 - march plaza industrial project, perris\dwg\4685 f-2.dwg LDP 09:53:53 01-29-2024 kopulsky

SOURCE: GOOGLE

KEY

 = PROJECT SITE



FIGURE 2

EXISTING SITE AERIAL
MARCH PLAZA, PERRIS

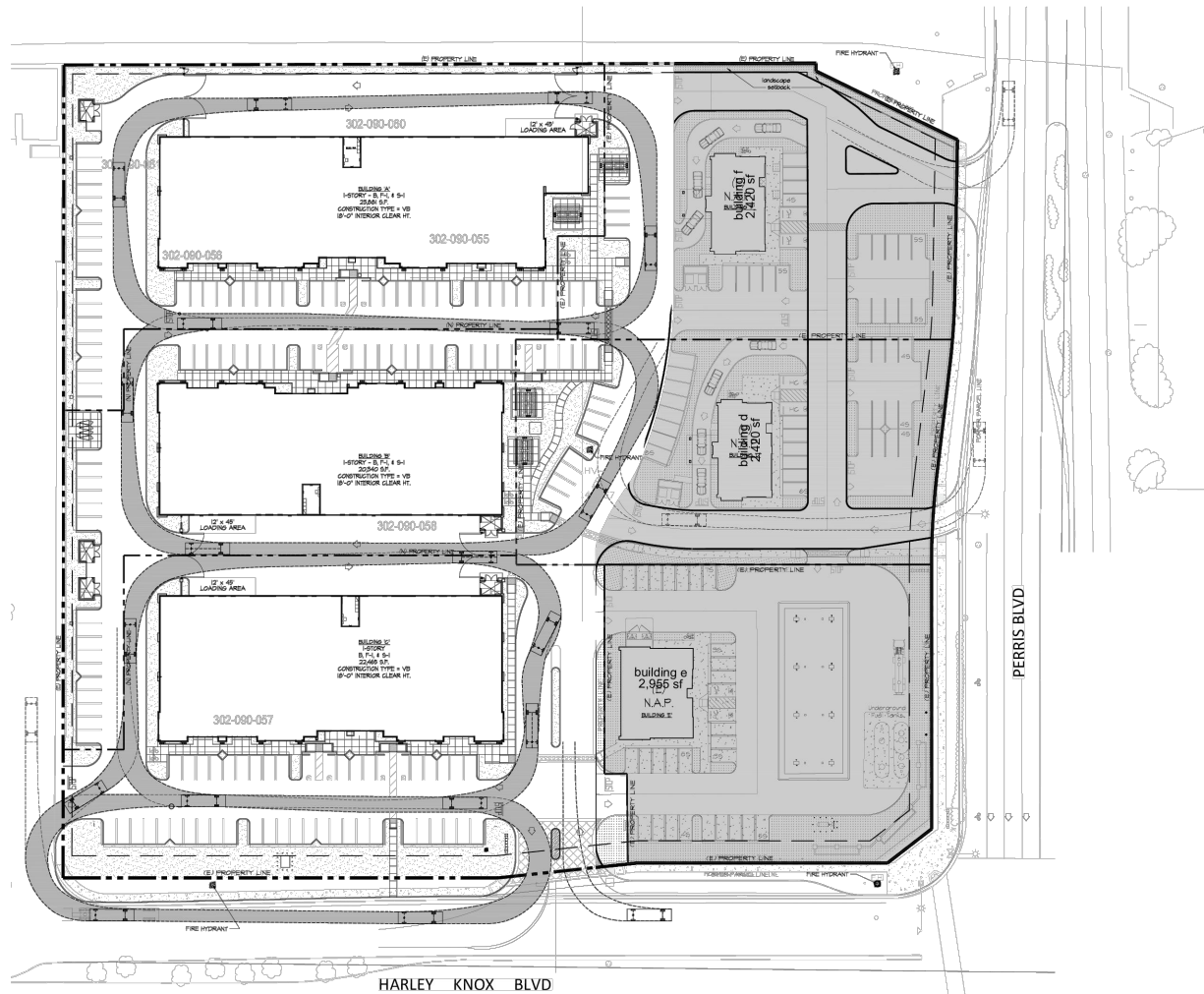

n:\4600\2234685 - march plaza industrial project, perris\dwg\4685 f-3.dwg LDP 09:54:23 01-29-2024 kopulsky

SOURCE: PK ARCHITECTURE



FIGURE 3

PROPOSED SITE PLAN
MARCH PLAZA, PERRIS

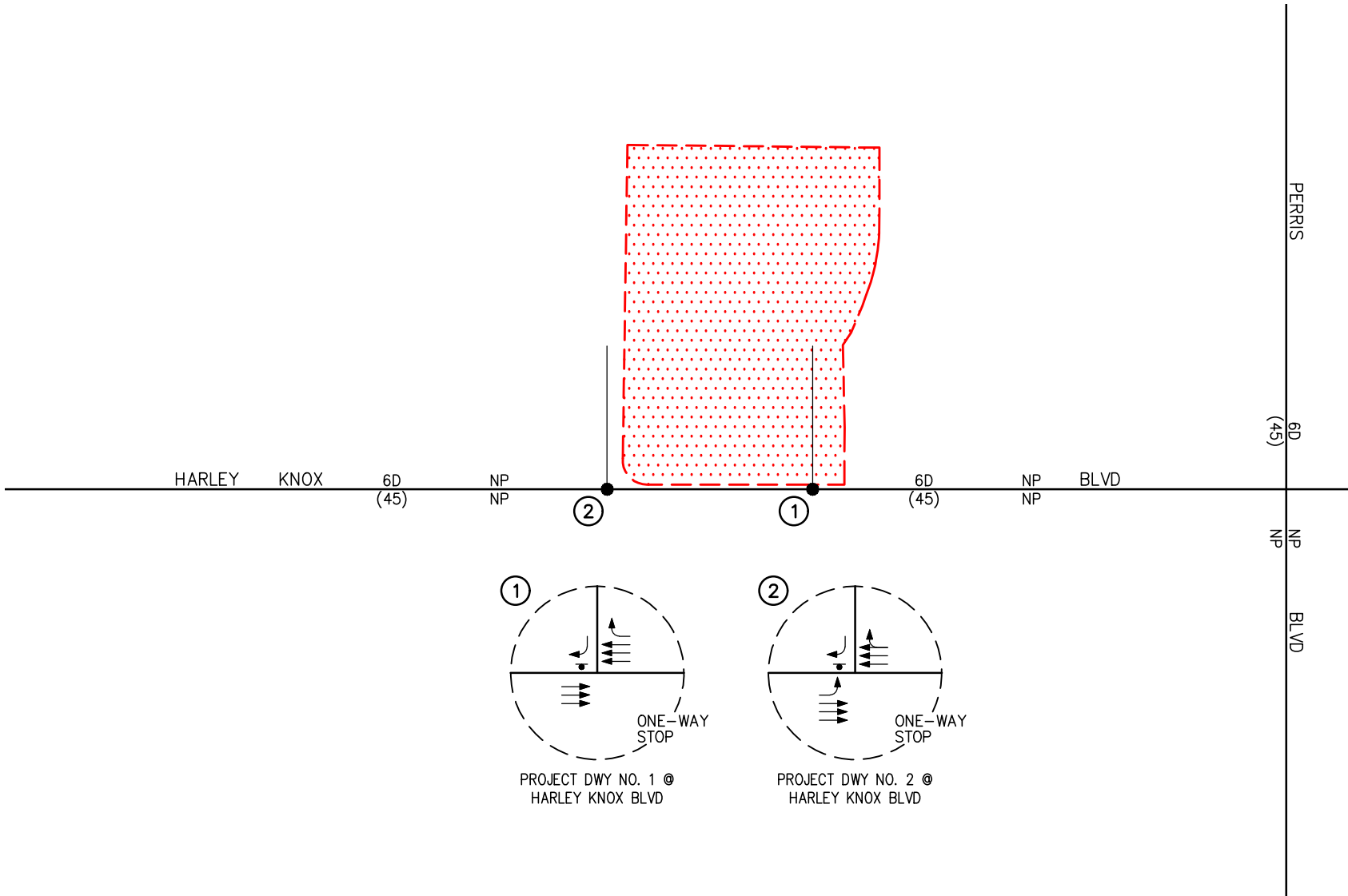

n:\4600\2234685 - march plaza industrial project, perris\dwg\4685 f-4.dwg LDP 13:44:39 01-25-2024 aguilan



- KEY**
- ← = APPROACH LANE ASSIGNMENT
 - = TRAFFIC SIGNAL, ▼ = STOP SIGN
 - P = PARKING, NP = NO PARKING
 - U = UNDIVIDED, D = DIVIDED
 - 2 = NUMBER OF TRAVEL LANES
 - (XX) = POSTED SPEED LIMIT (MPH)
 - [Red Hatched Box] = PROJECT SITE

FIGURE 4
EXISTING ROADWAY CONDITIONS AND INTERSECTION CONTROLS
 MARCH PLAZA, PERRIS

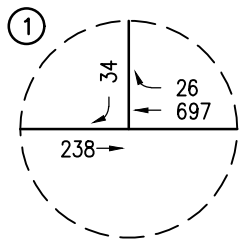

PROJECT DWY NO. 1 @
HARLEY KNOX BLVD

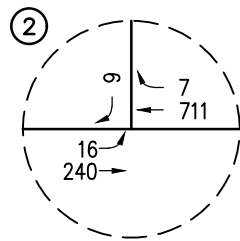

PROJECT DWY NO. 2 @
HARLEY KNOX BLVD

HARLEY KNOX

②

①

BLVD

PERRIS

BLVD

AM PEAK HOUR

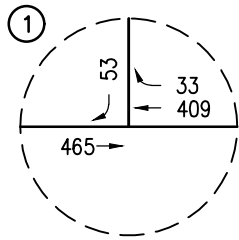

PROJECT DWY NO. 1 @
HARLEY KNOX BLVD

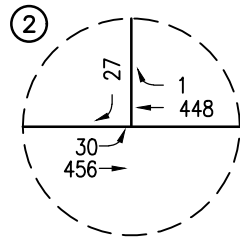

PROJECT DWY NO. 2 @
HARLEY KNOX BLVD

HARLEY KNOX

②

①

BLVD

PERRIS

BLVD

PM PEAK HOUR

n:\4600\2234685 - march plaza industrial project, perris\dwg\4685 f-5.dwg LDP 10:53:52 01-29-2024 aguilera



FIGURE 5

EXISTING PEAK HOUR TRAFFIC VOLUMES
MARCH PLAZA, PERRIS

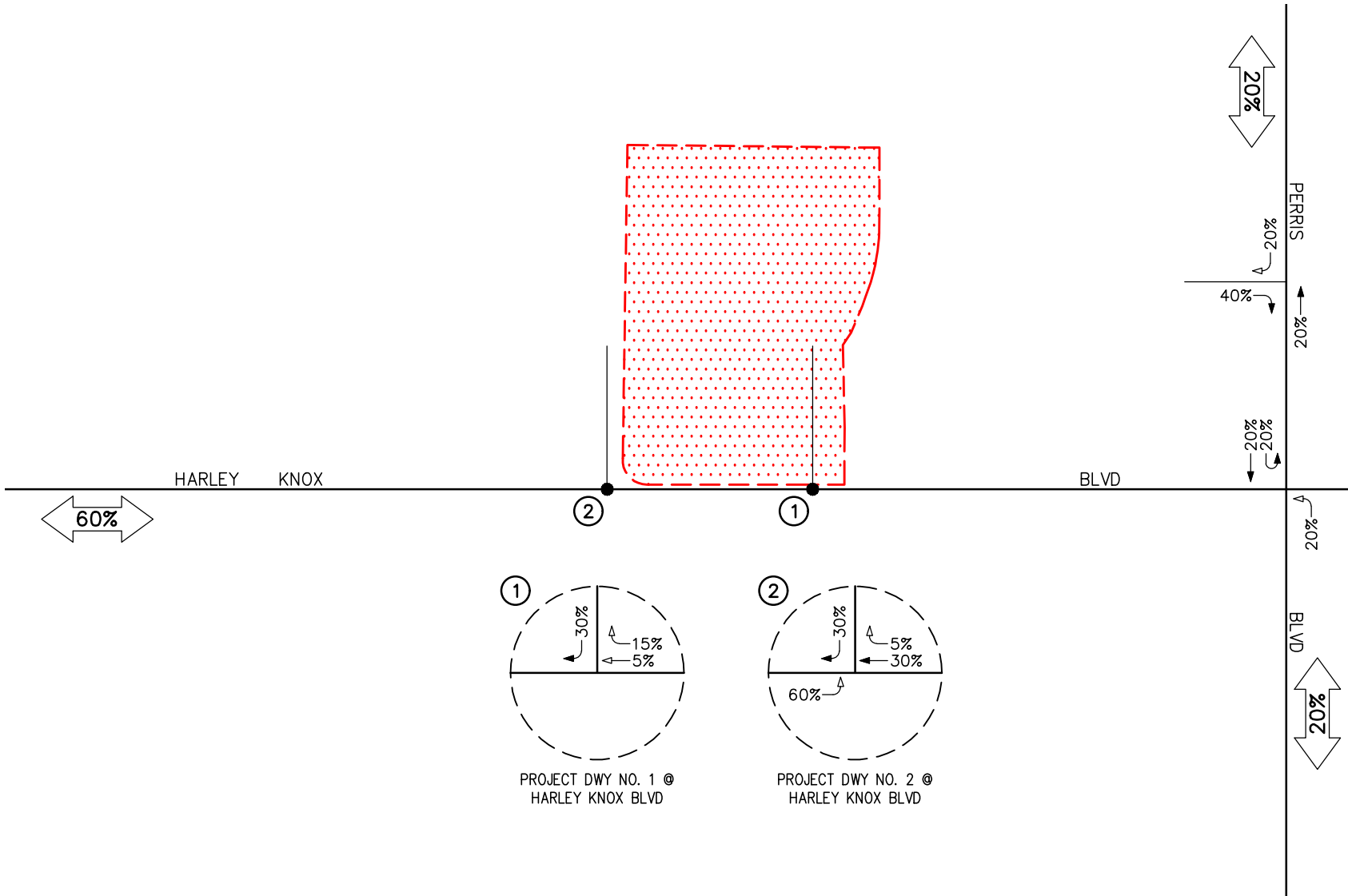

n:\4600\2234685 - march plaza industrial project, perris\dwg\4685 f-6.dwg LDP 08:22:14 01-31-2024 aguilan



- KEY**
- ① = STUDY INTERSECTION
 - ← = INBOUND PERCENTAGE
 - = OUTBOUND PERCENTAGE
 - ▨ = PROJECT SITE

FIGURE 6

PROJECT TRAFFIC DISTRIBUTION PATTERN
MARCH PLAZA, PERRIS

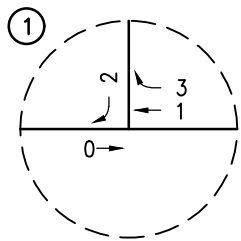

PROJECT DWY NO. 1 @ HARLEY KNOX BLVD

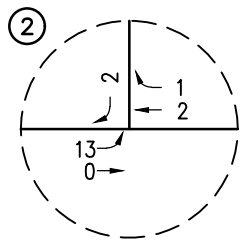

PROJECT DWY NO. 2 @ HARLEY KNOX BLVD

HARLEY KNOX

②

①

BLVD

PERRIS BLVD

5

AM PEAK HOUR

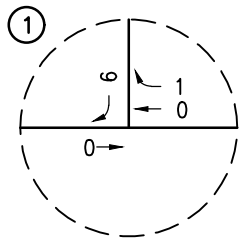

PROJECT DWY NO. 1 @ HARLEY KNOX BLVD

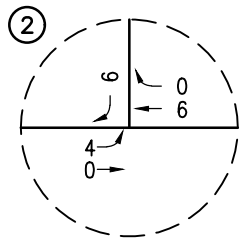

PROJECT DWY NO. 2 @ HARLEY KNOX BLVD

HARLEY KNOX

②

①

BLVD

PERRIS BLVD

1

PM PEAK HOUR

n:\4600\2234685 - march plaza industrial project, perris\dwg\4685 f-7.dwg LDP 08:25:27 01-31-2024 aguilera

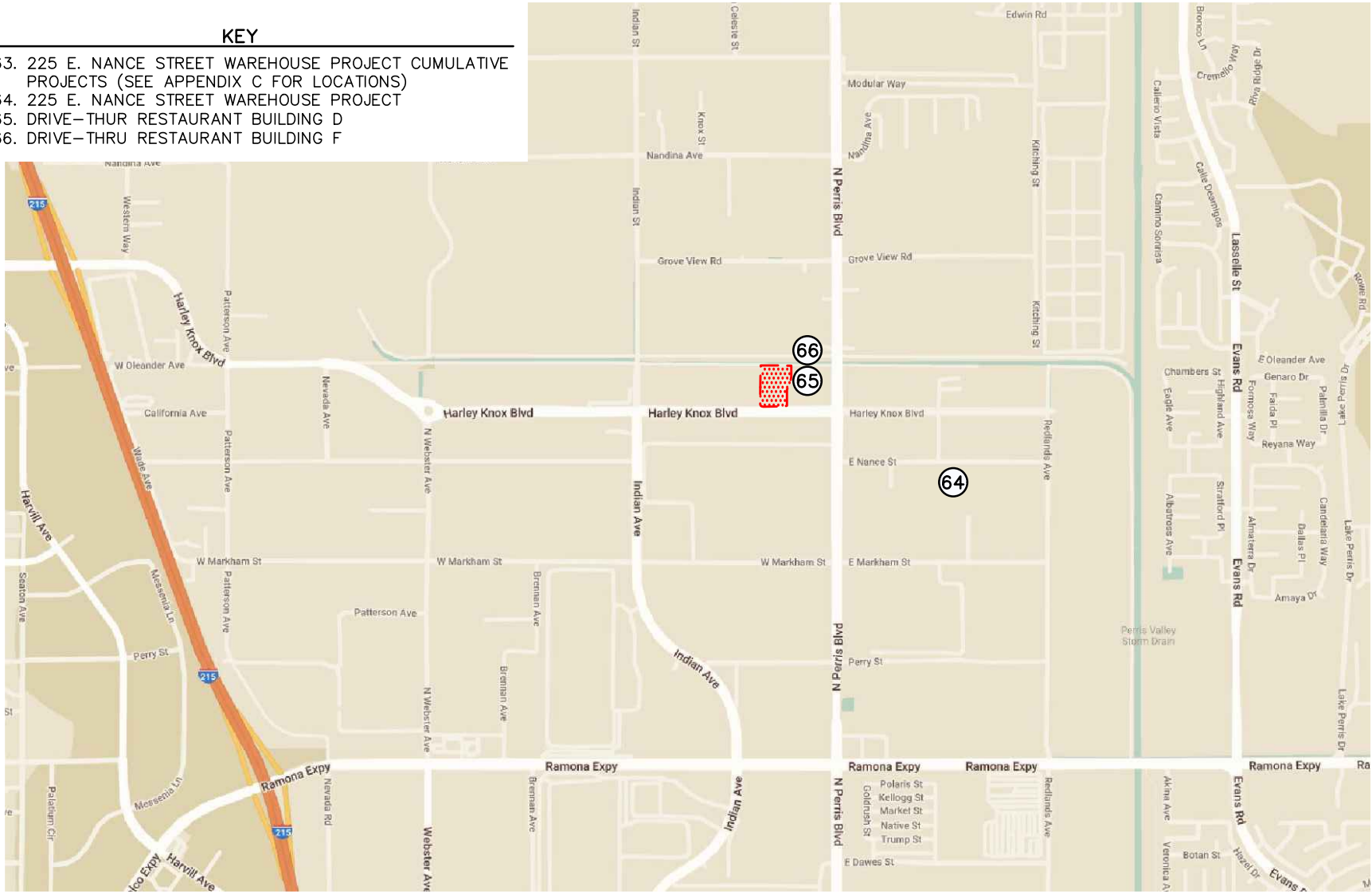

FIGURE 7

PEAK HOUR PROJECT TRAFFIC VOLUMES
MARCH PLAZA, PERRIS

KEY

- 1-63. 225 E. NANCE STREET WAREHOUSE PROJECT CUMULATIVE PROJECTS (SEE APPENDIX C FOR LOCATIONS)
- 64. 225 E. NANCE STREET WAREHOUSE PROJECT
- 65. DRIVE-THRU RESTAURANT BUILDING D
- 66. DRIVE-THRU RESTAURANT BUILDING F



n:\4600\2234685 - march plaza industrial project, perris\dwg\4685 f-8.dwg LDP 13:56:58 01-25-2024 aguilor

SOURCE: GOOGLE

KEY

- = STUDY INTERSECTION
- = PROJECT SITE



FIGURE 8

LOCATION OF CUMULATIVE PROJECTS
MARCH PLAZA, PERRIS

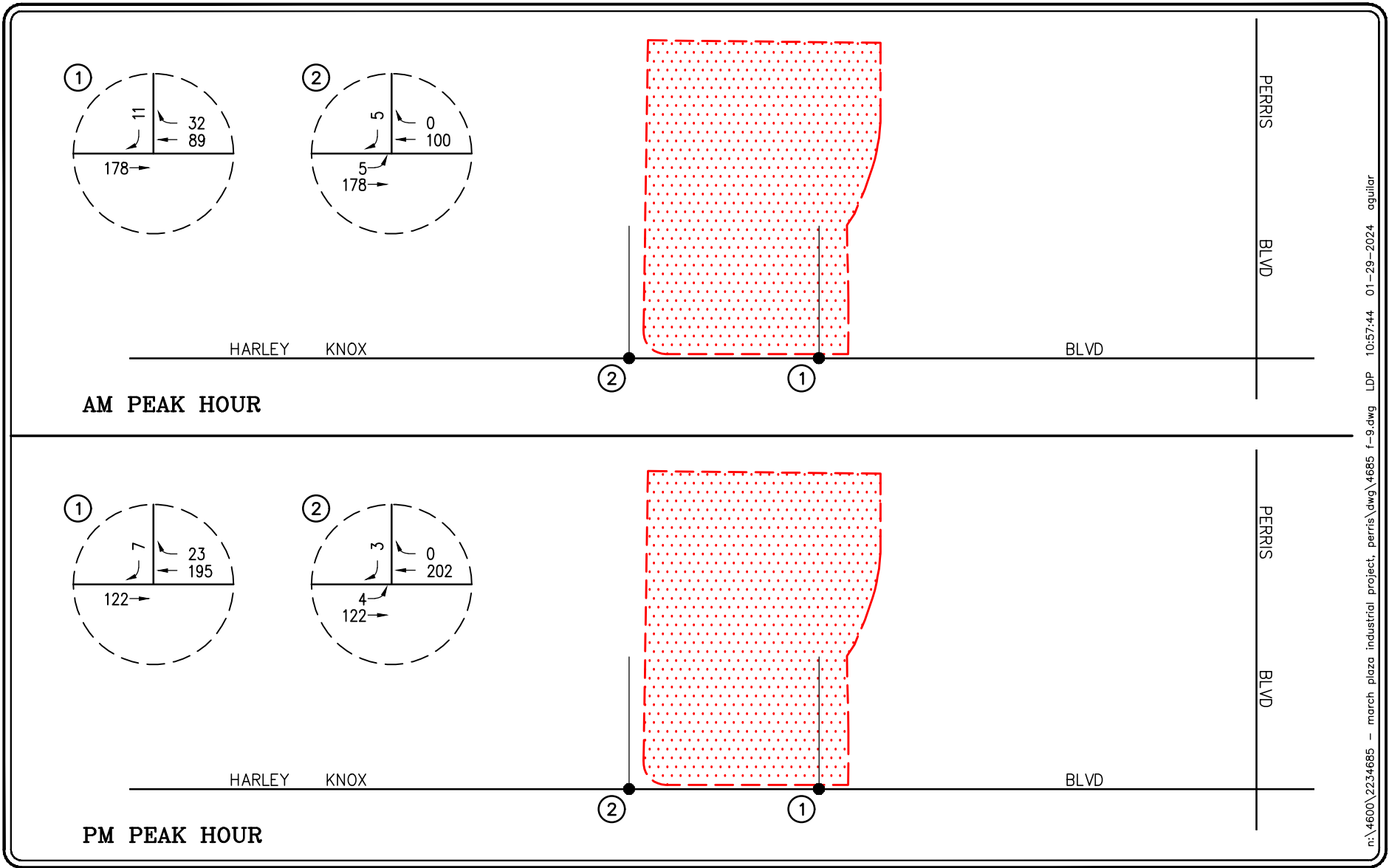

n:\4600\2234685 - march plaza industrial project, perris\dwg\4685 f-9.dwg LDP 10:57:44 01-29-2024 aguilera



FIGURE 9

CUMULATIVE PROJECT PEAK HOUR TRAFFIC VOLUMES
MARCH PLAZA, PERRIS

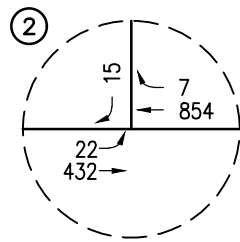
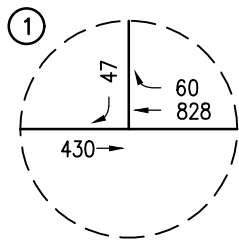

HARLEY KNOX

②

①

BLVD

PERRIS
BLVD

AM PEAK HOUR

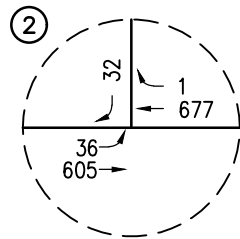
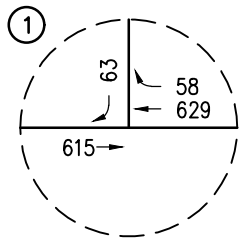

HARLEY KNOX

②

①

BLVD

PERRIS
BLVD

PM PEAK HOUR

n:\4600\2234685 - march plaza industrial project, perris\dwg\4685 f-10.dwg LDP 10:59:00 01-29-2024 agular



FIGURE 10

YEAR 2026 CUMULATIVE
PEAK HOUR TRAFFIC VOLUMES
MARCH PLAZA, PERRIS

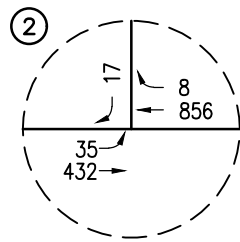
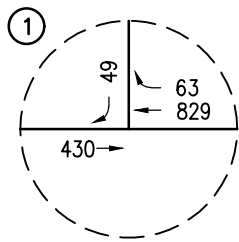

HARLEY KNOX

②

①

BLVD

PERRIS

BLVD

AM PEAK HOUR

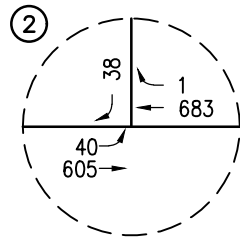
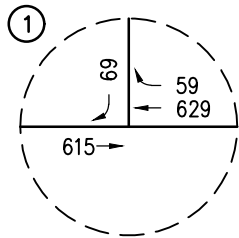

HARLEY KNOX

②

①

BLVD

PERRIS

BLVD

PM PEAK HOUR

n:\4600\2234685 - march plaza industrial project, perris\dwg\4685 f-11.dwg LDP 11:00:30 01-29-2024 agular



FIGURE 11

YEAR 2026 CUMULATIVE PLUS PROJECT
PEAK HOUR TRAFFIC VOLUMES
MARCH PLAZA, PERRIS

TABLE 1
LEVEL OF SERVICE CRITERIA FOR UNSIGNALIZED INTERSECTIONS (HCM 7 METHODOLOGY)^{1,2}
MARCH PLAZA PROJECT, PERRIS

Level of Service (LOS)	Highway Capacity Manual Delay Value (sec/veh)	Level of Service Description
A	≤ 10.0	Little or no delay
B	> 10.0 and ≤ 15.0	Short traffic delays
C	> 15.0 and ≤ 25.0	Average traffic delays
D	> 25.0 and ≤ 35.0	Long traffic delays
E	> 35.0 and ≤ 50.0	Very long traffic delays
F	> 50.0	Severe congestion

¹ Source: *Highway Capacity Manual 7*, Chapter 20: Two-Way Stop-Controlled Intersections. The LOS criteria apply to each lane on a given approach and to each approach on the minor street. LOS is not calculated for major-street approaches or for the intersection as a whole.

² Source: *Highway Capacity Manual 7*, Chapter 21: All-Way Stop-Controlled Intersections. For approaches and intersection-wide assessment, LOS is defined solely by control delay.



TABLE 2
PROJECT TRIP GENERATION RATES AND FORECAST WITH PCE CONVERSION FACTORS³
MARCH PLAZA PROJECT, PERRIS

ITE Land Use Code / Project Description	Daily 2-Way	AM Peak Hour			PM Peak Hour		
		Enter	Exit	Total	Enter	Exit	Total
<u>Generation Rates:</u>							
▪ 130: Industrial Park (TE/TSF)⁴	3.37	0.28	0.06	0.34	0.07	0.27	0.34
❑ Passenger Cars – 83.1% Daily/88.2% AM/88.2% PM (TE/TSF)	2.79	0.24	0.05	0.29	0.06	0.23	0.29
❑ 2 Axle Trucks – 2.82% Daily/1.97% AM/1.97% PM (TE/TSF)	0.10	0.01	0.00	0.01	0.00	0.01	0.01
❑ 3 Axle Trucks – 3.5% Daily/2.44% AM/2.44% PM (TE/TSF)	0.12	0.01	0.00	0.01	0.00	0.01	0.01
❑ 4+ Axle Trucks – 10.58% Daily/7.39% AM/7.39% PM (TE/TSF)	0.36	0.02	0.01	0.03	0.01	0.02	0.03
<u>Proposed Project Generation Forecast</u>							
▪ March Plaza Project (66.686 TSF)							
❑ Passenger Cars	186	16	3	19	4	15	19
❑ 2 Axle Trucks	10	1	0	1	0	1	1
❑ 3 Axle Trucks	16	1	0	1	0	1	1
❑ 4+ Axle Trucks	<u>72</u>	<u>4</u>	<u>2</u>	<u>6</u>	<u>2</u>	<u>4</u>	<u>6</u>
March Plaza Project Total	284	22	5	27	6	21	27

Notes:

- TE/TSF = Trip End per Thousand Square Feet
- PCE = Passenger Car Equivalent

³ Source: *Trip Generation, 11th Edition*, Institute of Transportation Engineers, (ITE) [Washington, D.C. (2021)].

⁴ Truck splits are based on ITE. Recommended mix of truck traffic is based on *SCAQMD, "Without Cold Storage"*. All 2-axle, 3-axle and 4+-axle trucks are converted to passenger car equivalents using a factor of 1.5 vehicles per truck, 2.0 vehicles per truck, and 3.0 vehicles per truck, respectively.



TABLE 3
LOCATION AND DESCRIPTION OF CUMULATIVE PROJECTS⁵
MARCH PLAZA PROJECT, PERRIS

No.	Description	Location/Address	Size
<u>City of Perris</u>			
1-63.	255 E. Nance Street Warehouse Project Cumulative Projects	See <i>Appendix C</i> for a map of project locations	See <i>Appendix C</i> for table of project descriptions
64.	255 E. Nance Street Warehouse Project	Nance Street between Perris Boulevard and Redlands Avenue	202,500 SF Warehouse
65.	Drive-Thru Restaurant Building D	NWC of Perris Boulevard at Harley Knox Boulevard	2,420 SF Drive-Thru Restaurant
66.	Drive-Thru Restaurant Building F	NWC of Perris Boulevard at Harley Knox Boulevard	2,420 SF Drive-Thru Restaurant

⁵ Source: City of Perris staff.



TABLE 4
CUMULATIVE PROJECTS TRAFFIC GENERATION FORECAST⁶
MARCH PLAZA PROJECT, PERRIS

No.	Cumulative Project Description	Daily Two-Way	AM Peak Hour			PM Peak Hour		
			In	Out	Total	In	Out	Total
1-63.	255 E. Nance Street Warehouse Project Cumulative Projects ⁷	63,731	2,621	1,950	4,571	2,464	3,280	5,744
64.	255 E. Nance Street Warehouse Project ⁷	495	37	13	50	15	37	52
65.	Drive-Thru Restaurant Building D	848	27	27	54	19	17	36
66.	Drive-Thru Restaurant Building F	848	27	27	54	19	17	36
Total Cumulative Projects Trip Generation Forecast		65,922	2,712	2,017	4,729	2,517	3,351	5,868

⁶ Unless otherwise noted, Source: *Trip Generation Manual, 11th Edition*, Institute of Transportation Engineers (ITE) [Washington, D.C. (2021)].

⁷ Source: *255 E. Nance Street Warehouse Project Transportation Impact Analysis*, prepared by Dudek, dated February 2023.



TABLE 5
YEAR 2026 CUMULATIVE PLUS PROJECT PEAK HOUR INTERSECTION CAPACITY ANALYSIS SUMMARY
MARCH PLAZA PROJECT, PERRIS

Key Intersection	Time Period	Minimum Acceptable LOS	(1)		(2)		(3)		(4)	
			Existing Traffic Conditions		Year 2026 Cumulative Traffic Conditions		Year 2026 Cumulative Plus Project Traffic Conditions		Impact	
			HCM	LOS	HCM	LOS	HCM	LOS	Increase	LOS
1. Project Driveway No. 1 at Harley Knox Boulevard	AM	D	12.3 s/v	B	12.9 s/v	B	13.0 s/v	B	0.1 s/v	No
	PM		11.3 s/v	B	12.0 s/v	B	12.0 s/v	B	0.0 s/v	No
2. Project Driveway No. 2 at Harley Knox Boulevard	AM	D	12.0 s/v	B	12.6 s/v	B	12.6 s/v	B	0.0 s/v	No
	PM		11.2 s/v	B	11.8 s/v	B	11.9 s/v	B	0.1 s/v	No

Notes:

- s/v = seconds per vehicle (delay)
- LOS = Level of Service
- The delay reported for the unsignalized intersections (i.e. intersections #1 and #2) is the worst side-street approach delay

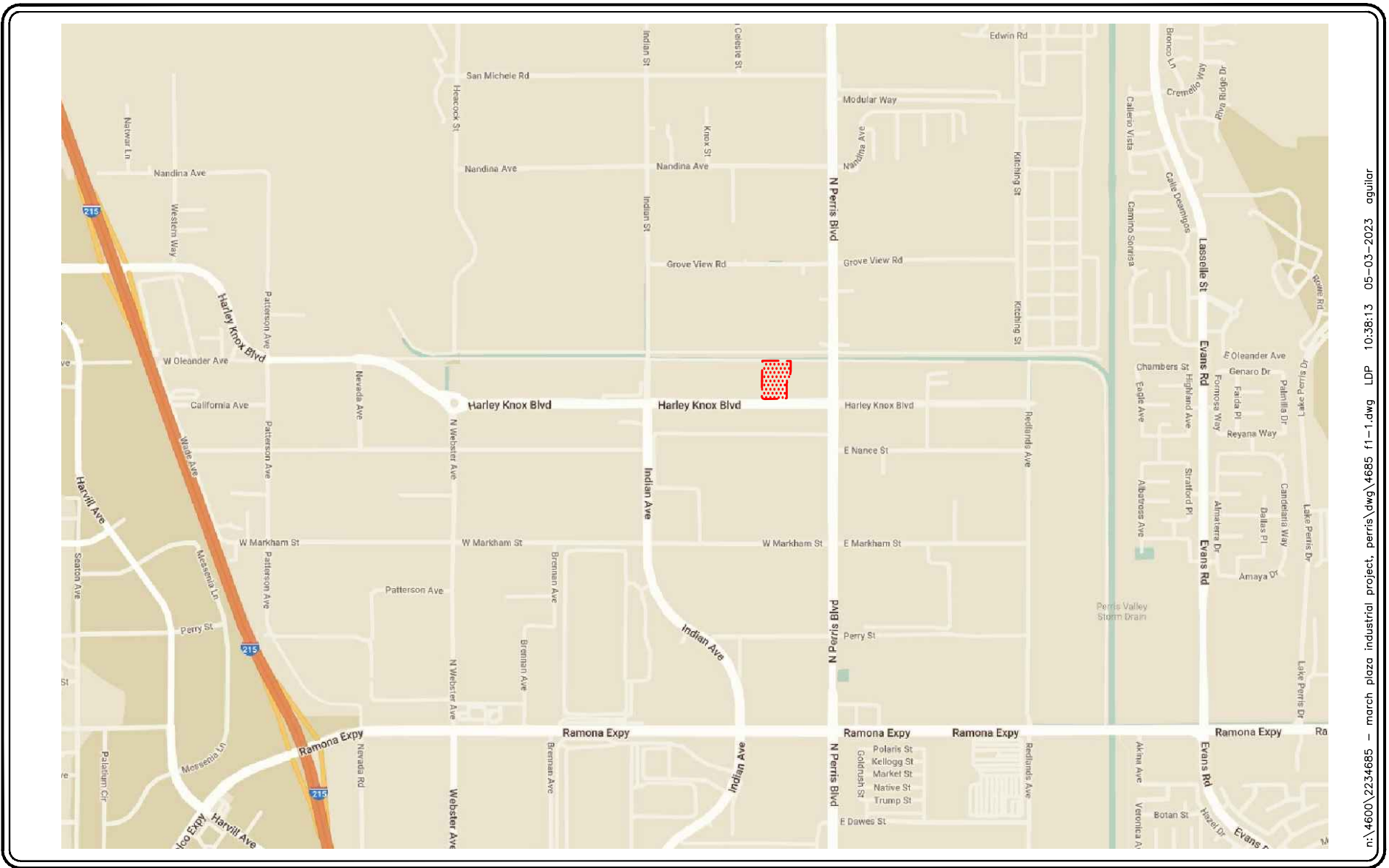

TABLE 6
YEAR 2026 CUMULATIVE PLUS PROJECT PEAK HOUR QUEUING ANALYSIS⁸
MARCH PLAZA PROJECT, PERRIS

Key Intersection	Estimated Storage Provided	Year 2026 Cumulative Plus Project Traffic Conditions				
		AM Peak Hour		PM Peak Hour		
		Max. Queue	Adequate Storage (Yes / No)	Max. Queue	Adequate Storage (Yes / No)	
1. Project Driveway No. 1 at Harley Knox Boulevard <i>Southbound Right-Turn</i>	50'	25'	Yes	25'	Yes	
2. Project Driveway No. 2 at Harley Knox Boulevard	<i>Southbound Right-Turn</i>	40'	25'	Yes	25'	Yes
	<i>Eastbound Left-Turn</i>	210'	25'	Yes	25'	Yes

⁸ Queue is based on the 95th Percentile Queue and is reported in total queue length (feet) per lane for signalized intersections.

APPENDIX A
TRAFFIC STUDY SCOPE OF WORK



n:\4600\2234685 - march plaza industrial project, perris\dwg\4685 f1-1.dwg LDP 10:38:13 05-03-2023 agular

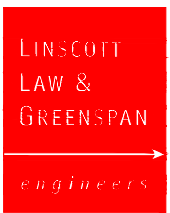

SOURCE: GOOGLE
 KEY
 [Red hatched box] = PROJECT SITE

FIGURE 1

VICINITY MAP
 MARCH PLAZA INDUSTRIAL PROJECT, PERRIS



n:\4600\2234685 - march plaza industrial project, perris\dwg\4685 f2-1.dwg LDP 07-24-19 05-05-2023 aguilan

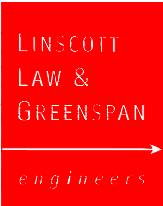

SOURCE: GOOGLE

KEY

 = PROJECT SITE

FIGURE 2

EXISTING SITE AERIAL
MARCH PLAZA INDUSTRIAL PROJECT, PERRIS

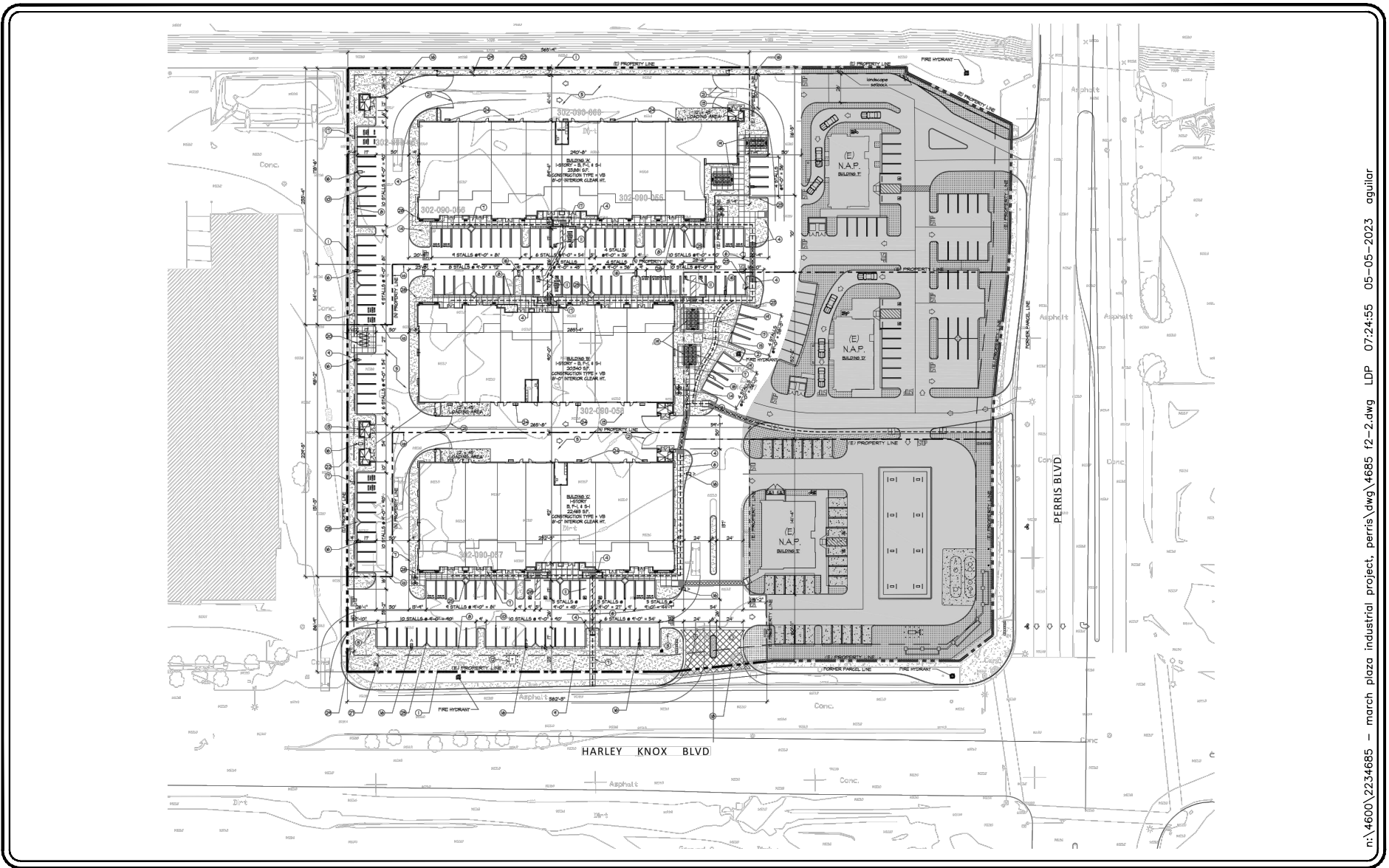

n:\4600\2234685 - march plaza industrial project, perris\dwg\4685 f2-2.dwg LDP 07-24-55 05-05-2023 agular

SOURCE: PK ARCHITECTURE

FIGURE 3

PROPOSED SITE PLAN
 MARCH PLAZA INDUSTRIAL PROJECT, PERRIS

LINSCOTT
 LAW &
 GREENSPAN
 engineers

NO SCALE

TABLE 1
PROJECT TRIP GENERATION RATES AND FORECAST¹
MARCH PLAZA INDUSTRIAL PROJECT, PERRIS

ITE Land Use Code / Project Description	Daily 2-Way	AM Peak Hour			PM Peak Hour		
		Enter	Exit	Total	Enter	Exit	Total
<u>Generation Rates:</u>							
▪ 130: Industrial Park (TE/TSF)	3.37	81%	19%	0.34	22%	78%	0.34
<u>Proposed Project Generation Forecast</u>							
▪ March Plaza Industrial Project (66.686 TSF)	225	19	4	23	5	18	23

Notes:

- TE/TSF = Trip End per Thousand Square Feet

¹ Source: *Trip Generation, 11th Edition*, Institute of Transportation Engineers, (ITE) [Washington, D.C. (2021)].

WRCOG VMT Screening Tool Results (Continued) March Plaza Industrial Project, Perris

WRCOG VMT Tool Powered by Fehr & Peers User's Guide

Find address or place

Complete #1-4, Then Click *Run*

Input Output

#1. Zoom in on the map to your project location so parcels appear on map. Next, select 'Parcels' from the drop-down. Then click the black square next to the drop-down so you can select the parcel(s) for your project by drawing a simple rectangle over the parcel(s) you need.*

Parcels (Zoom in to view) [X] [Y]

#2. Select the VMT Metric. Note each jurisdiction may have adopted a different metric by which they measure VMT. Please consult with the jurisdiction to verify which metric to use for your analysis.*

PA VMT Per Worker

#3. Select the Baseline Year. The year available for analysis are from 2018 to 2045.*

2018

#4. Select the Threshold (% reduction from baseline year). Note each jurisdiction may have adopted a different metric by which they measure VMT. Please consult with the jurisdiction to verify which metric to use for your analysis.*

Below City Baseline (0%)

[Help](#) Run

[2 of 6]

OBJECTID	7
Assessor Parcel Number (APN)	302090058
Traffic Analysis Zone (TAZ)	1873
Community Region	PERRIS
Inside a Transit Priority Area (TPA)	Yes
TAZ VMT	16.9
Jurisdiction VMT	17.1
% Difference	-1.17%
VMT Metric	PA VMT Per Worker
Threshold	17.1
Community	0
Zoom to	...

Map labels: Oleander Ave, Herley Knox Blvd, Johnson St, Roman St, Perris Blvd, Perris Blvd, Johnson St, Roman St, Johnson St, Roman St, Johnson St, Roman St.

Scale: 800ft
Coordinates: -117.229 33.854 Degrees

POWERED BY esri

APPENDIX B
EXISTING TRAFFIC COUNT DATA

City: PERRIS
 N-S Direction: 7-ELEVEN DRIVEWAY
 E-W Direction: HARLEY KNOX BLVD

File Name : H2401001
 Site Code : 00000000
 Start Date : 1/9/2024
 Page No : 1

Groups Printed- Vehicles

Start Time	7-ELEVEN DRIVEWAY Southbound				HARLEY KNOX BLVD Westbound				DEAD END Northbound				HARLEY KNOX BLVD Eastbound				Int. Total
	Right	Thru	Left	U Turns	Right	Thru	Left	U Turns	Right	Thru	Left	U Turns	Right	Thru	Left	U Turns	
07:00	9	0	0	0	6	137	0	0	0	0	0	0	0	34	0	0	186
07:15	8	0	0	0	4	163	0	0	0	0	0	0	0	25	0	0	200
07:30	8	0	0	0	5	132	0	0	0	0	0	0	0	27	0	0	172
07:45	5	0	0	0	5	136	0	0	0	0	0	0	0	41	0	0	187
Total	30	0	0	0	20	568	0	0	0	0	0	0	0	127	0	0	745
08:00	4	0	0	0	5	68	0	0	0	0	0	0	0	30	0	0	107
08:15	6	0	0	0	6	78	0	0	0	0	0	0	0	42	0	0	132
08:30	10	0	0	0	2	51	0	0	0	0	0	0	0	36	0	0	99
08:45	7	0	0	0	1	33	0	0	0	0	0	0	0	37	0	0	78
Total	27	0	0	0	14	230	0	0	0	0	0	0	0	145	0	0	416
16:00	15	0	0	0	8	64	0	0	0	0	0	0	0	83	0	0	170
16:15	13	0	0	0	10	69	0	0	0	0	0	0	0	83	0	0	175
16:30	12	0	0	0	6	84	0	0	0	0	0	0	0	123	0	0	225
16:45	4	0	0	0	7	70	0	0	0	0	0	0	0	86	0	0	167
Total	44	0	0	0	31	287	0	0	0	0	0	0	0	375	0	0	737
17:00	10	0	0	0	2	37	0	0	0	0	0	0	0	87	0	0	136
17:15	6	0	0	0	5	62	0	0	0	0	0	0	0	84	0	0	157
17:30	8	0	0	0	5	64	0	0	0	0	0	0	0	97	0	0	174
17:45	5	0	0	0	6	39	0	0	0	0	0	0	0	80	0	0	130
Total	29	0	0	0	18	202	0	0	0	0	0	0	0	348	0	0	597
Grand Total	130	0	0	0	83	1287	0	0	0	0	0	0	0	995	0	0	2495
Apprch %	100	0	0	0	6.1	93.9	0	0	0	0	0	0	0	100	0	0	
Total %	5.2	0	0	0	3.3	51.6	0	0	0	0	0	0	0	39.9	0	0	

City: PERRIS
 N-S Direction: 7-ELEVEN DRIVEWAY
 E-W Direction: HARLEY KNOX BLVD

File Name : H2401001
 Site Code : 0000000
 Start Date : 1/9/2024
 Page No : 2

Start Time	7-ELEVEN DRIVEWAY Southbound					HARLEY KNOX BLVD Westbound					DEAD END Northbound					HARLEY KNOX BLVD Eastbound					Int. Total
	Right	Thru	Left	U Turns	App. Total	Right	Thru	Left	U Turns	App. Total	Right	Thru	Left	U Turns	App. Total	Right	Thru	Left	U Turns	App. Total	
Peak Hour Analysis From 07:00 to 08:45 - Peak 1 of 1																					
Peak Hour for Entire Intersection Begins at 07:00																					
07:00	9	0	0	0	9	6	137	0	0	143	0	0	0	0	0	0	34	0	0	34	186
07:15	8	0	0	0	8	4	163	0	0	167	0	0	0	0	0	0	25	0	0	25	200
07:30	8	0	0	0	8	5	132	0	0	137	0	0	0	0	0	0	27	0	0	27	172
07:45	5	0	0	0	5	5	136	0	0	141	0	0	0	0	0	0	41	0	0	41	187
Total Volume	30	0	0	0	30	20	568	0	0	588	0	0	0	0	0	0	127	0	0	127	745
% App. Total	100	0	0	0		3.4	96.6	0	0		0	0	0	0		0	100	0	0		
PHF	.833	.000	.000	.000	.833	.833	.871	.000	.000	.880	.000	.000	.000	.000	.000	.000	.774	.000	.000	.774	.931

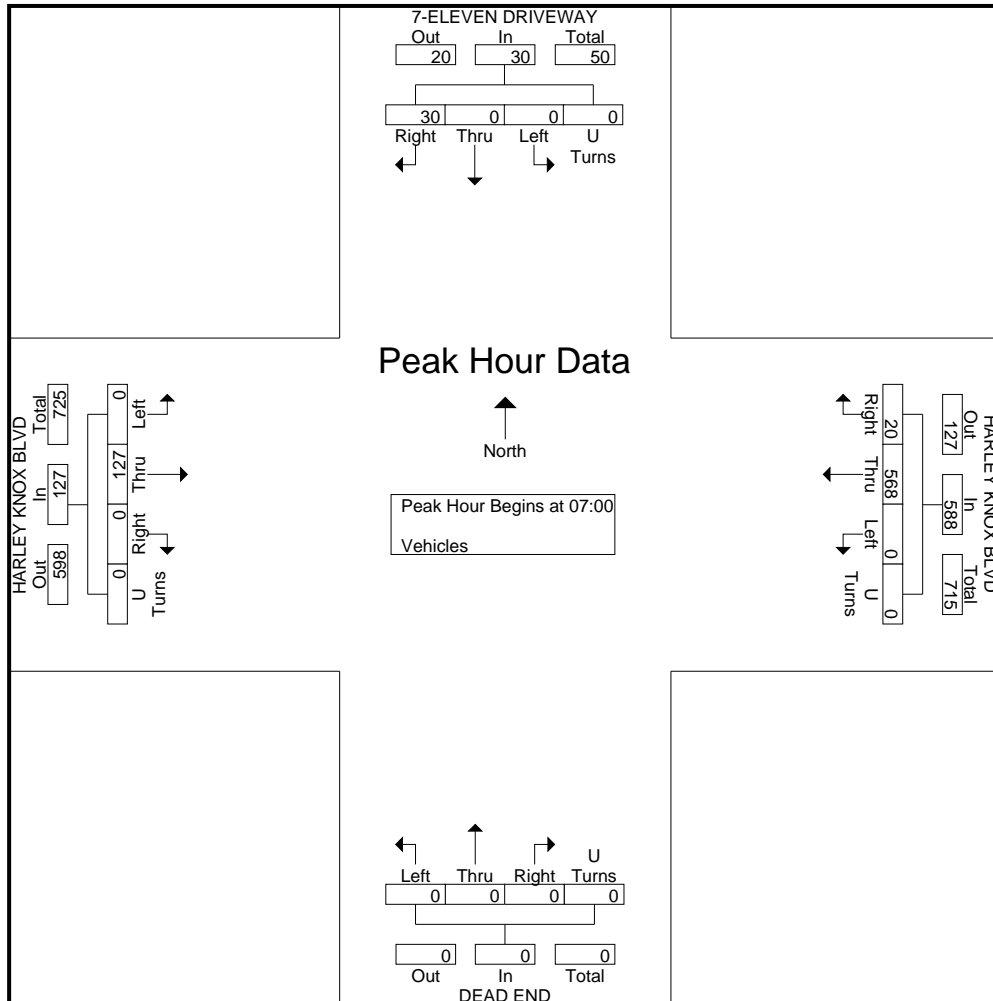

City: PERRIS
 N-S Direction: 7-ELEVEN DRIVEWAY
 E-W Direction: HARLEY KNOX BLVD

File Name : H2401001
 Site Code : 0000000
 Start Date : 1/9/2024
 Page No : 3

Start Time	7-ELEVEN DRIVEWAY Southbound					HARLEY KNOX BLVD Westbound					DEAD END Northbound					HARLEY KNOX BLVD Eastbound					Int. Total
	Right	Thru	Left	U Turns	App. Total	Right	Thru	Left	U Turns	App. Total	Right	Thru	Left	U Turns	App. Total	Right	Thru	Left	U Turns	App. Total	
Peak Hour Analysis From 16:00 to 17:45 - Peak 1 of 1																					
Peak Hour for Entire Intersection Begins at 16:00																					
16:00	15	0	0	0	15	8	64	0	0	72	0	0	0	0	0	0	83	0	0	83	170
16:15	13	0	0	0	13	10	69	0	0	79	0	0	0	0	0	0	83	0	0	83	175
16:30	12	0	0	0	12	6	84	0	0	90	0	0	0	0	0	0	123	0	0	123	225
16:45	4	0	0	0	4	7	70	0	0	77	0	0	0	0	0	0	86	0	0	86	167
Total Volume	44	0	0	0	44	31	287	0	0	318	0	0	0	0	0	0	375	0	0	375	737
% App. Total	100	0	0	0		9.7	90.3	0	0		0	0	0	0	0	0	100	0	0		
PHF	.733	.000	.000	.000	.733	.775	.854	.000	.000	.883	.000	.000	.000	.000	.000	.000	.762	.000	.000	.762	.819

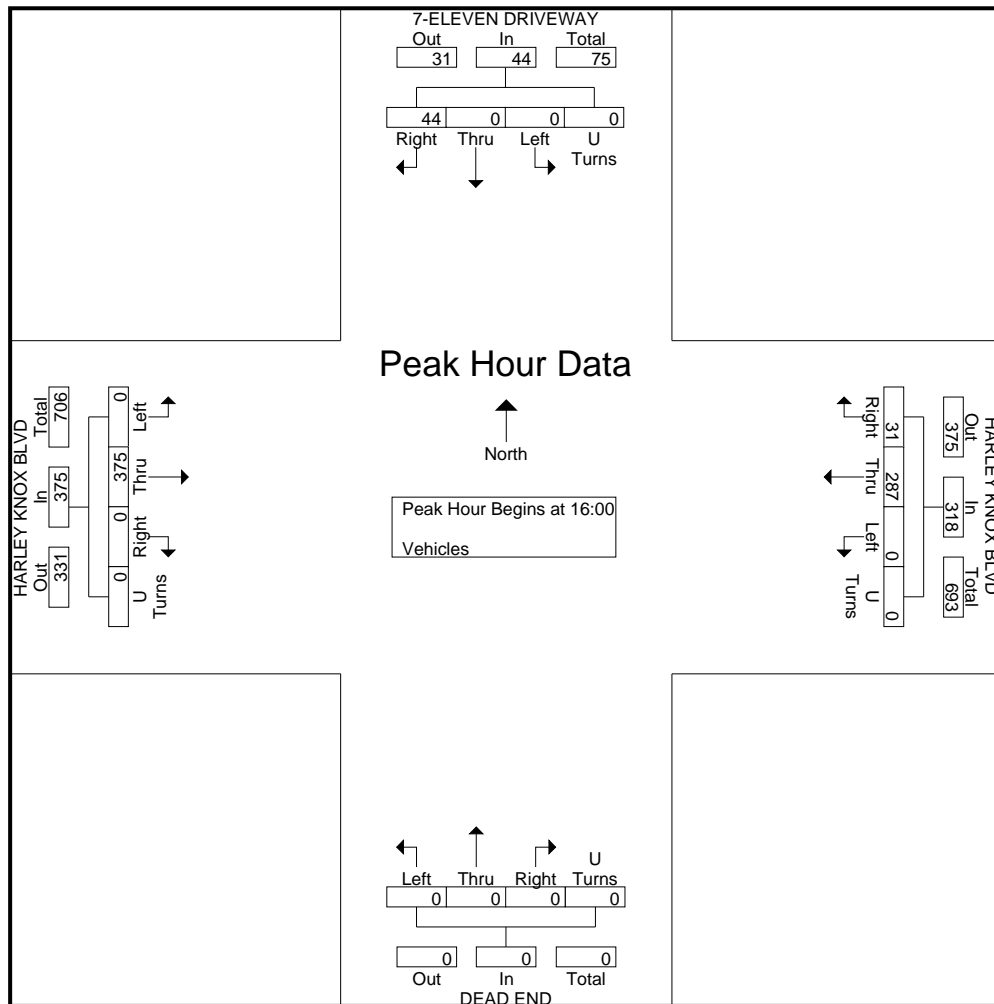

City: PERRIS
 N-S Direction: 7-ELEVEN DRIVEWAY
 E-W Direction: HARLEY KNOX BLVD

File Name : H2401001
 Site Code : 00000000
 Start Date : 1/9/2024
 Page No : 1

Groups Printed- Large 2 Axle

Start Time	7-ELEVEN DRIVEWAY Southbound				HARLEY KNOX BLVD Westbound				DEAD END Northbound				HARLEY KNOX BLVD Eastbound				Int. Total
	Right	Thru	Left	U Turns	Right	Thru	Left	U Turns	Right	Thru	Left	U Turns	Right	Thru	Left	U Turns	
07:00	0	0	0	0	0	2	0	0	0	0	0	0	0	0	0	0	2
07:15	1	0	0	0	0	1	0	0	0	0	0	0	0	1	0	0	3
07:30	0	0	0	0	0	2	0	0	0	0	0	0	0	1	0	0	3
07:45	0	0	0	0	0	1	0	0	0	0	0	0	0	4	0	0	5
Total	1	0	0	0	0	6	0	0	0	0	0	0	0	6	0	0	13
08:00	0	0	0	0	0	1	0	0	0	0	0	0	0	0	0	0	1
08:15	0	0	0	0	0	1	0	0	0	0	0	0	0	1	0	0	2
08:30	0	0	0	0	1	5	0	0	0	0	0	0	0	3	0	0	9
08:45	0	0	0	0	0	0	0	0	0	0	0	0	0	3	0	0	3
Total	0	0	0	0	1	7	0	0	0	0	0	0	0	7	0	0	15
16:15	0	0	0	0	0	0	0	0	0	0	0	0	0	1	0	0	1
16:30	0	0	0	0	0	0	0	0	0	0	0	0	0	1	0	0	1
16:45	0	0	0	0	0	0	0	0	0	0	0	0	0	2	0	0	2
Total	0	0	0	0	0	0	0	0	0	0	0	0	0	4	0	0	4
17:00	0	0	0	0	0	1	0	0	0	0	0	0	0	3	0	0	4
17:15	0	0	0	0	0	1	0	0	0	0	0	0	0	0	0	0	1
17:30	0	0	0	0	0	1	0	0	0	0	0	0	0	1	0	0	2
17:45	0	0	0	0	0	2	0	0	0	0	0	0	0	2	0	0	4
Total	0	0	0	0	0	5	0	0	0	0	0	0	0	6	0	0	11
Grand Total	1	0	0	0	1	18	0	0	0	0	0	0	0	23	0	0	43
Apprch %	100	0	0	0	5.3	94.7	0	0	0	0	0	0	0	100	0	0	
Total %	2.3	0	0	0	2.3	41.9	0	0	0	0	0	0	0	53.5	0	0	

City: PERRIS
 N-S Direction: 7-ELEVEN DRIVEWAY
 E-W Direction: HARLEY KNOX BLVD

File Name : H2401001
 Site Code : 0000000
 Start Date : 1/9/2024
 Page No : 2

Start Time	7-ELEVEN DRIVEWAY Southbound					HARLEY KNOX BLVD Westbound					DEAD END Northbound					HARLEY KNOX BLVD Eastbound					Int. Total
	Right	Thru	Left	U Turns	App. Total	Right	Thru	Left	U Turns	App. Total	Right	Thru	Left	U Turns	App. Total	Right	Thru	Left	U Turns	App. Total	
Peak Hour Analysis From 07:00 to 08:45 - Peak 1 of 1																					
Peak Hour for Entire Intersection Begins at 07:45																					
07:45	0	0	0	0	0	0	1	0	0	1	0	0	0	0	0	0	4	0	0	4	5
08:00	0	0	0	0	0	0	1	0	0	1	0	0	0	0	0	0	0	0	0	0	1
08:15	0	0	0	0	0	0	1	0	0	1	0	0	0	0	0	0	1	0	0	1	2
08:30	0	0	0	0	0	1	5	0	0	6	0	0	0	0	0	0	3	0	0	3	9
Total Volume	0	0	0	0	0	1	8	0	0	9	0	0	0	0	0	0	8	0	0	8	17
% App. Total	0	0	0	0	0	11.1	88.9	0	0		0	0	0	0	0	0	100	0	0		
PHF	.000	.000	.000	.000	.000	.250	.400	.000	.000	.375	.000	.000	.000	.000	.000	.000	.500	.000	.000	.500	.472

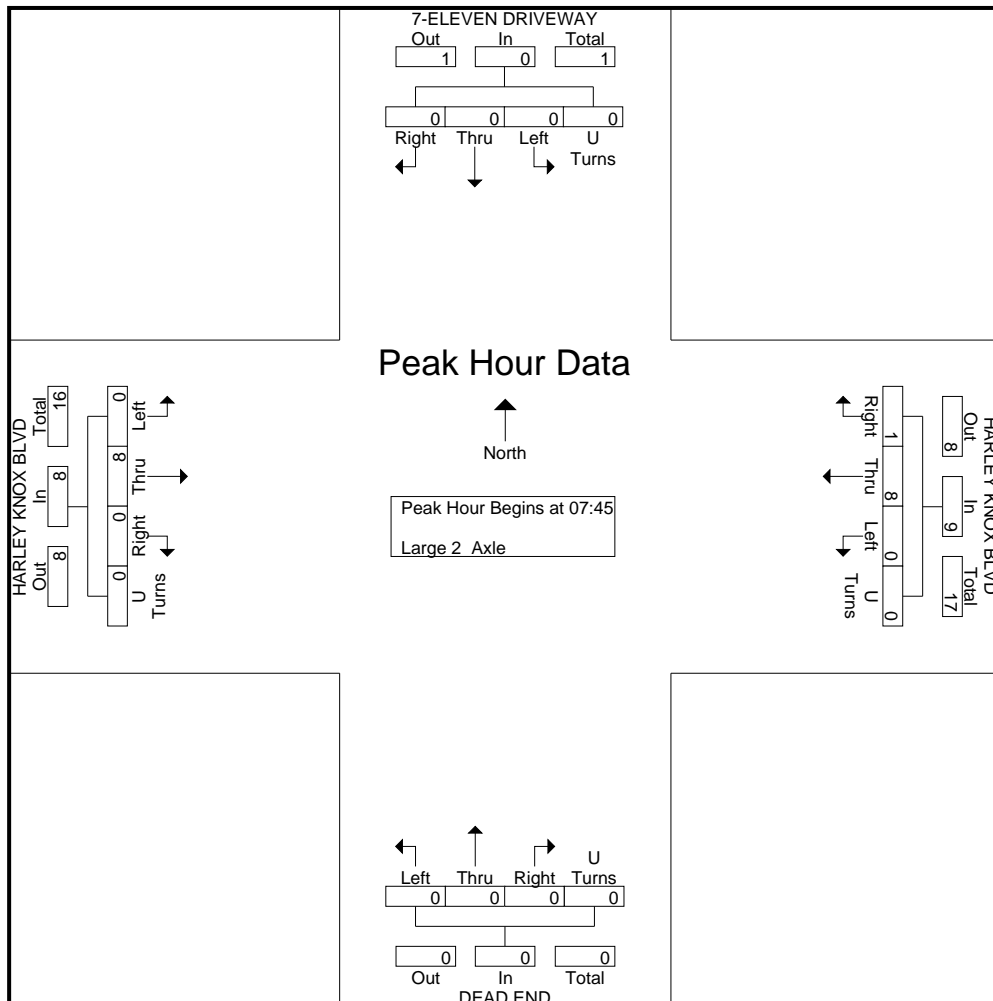

City: PERRIS
 N-S Direction: 7-ELEVEN DRIVEWAY
 E-W Direction: HARLEY KNOX BLVD

File Name : H2401001
 Site Code : 0000000
 Start Date : 1/9/2024
 Page No : 3

Start Time	7-ELEVEN DRIVEWAY Southbound					HARLEY KNOX BLVD Westbound					DEAD END Northbound					HARLEY KNOX BLVD Eastbound					Int. Total
	Right	Thru	Left	U Turns	App. Total	Right	Thru	Left	U Turns	App. Total	Right	Thru	Left	U Turns	App. Total	Right	Thru	Left	U Turns	App. Total	
Peak Hour Analysis From 16:00 to 17:45 - Peak 1 of 1																					
Peak Hour for Entire Intersection Begins at 17:00																					
17:00	0	0	0	0	0	0	1	0	0	1	0	0	0	0	0	0	3	0	0	3	4
17:15	0	0	0	0	0	0	1	0	0	1	0	0	0	0	0	0	0	0	0	0	1
17:30	0	0	0	0	0	0	1	0	0	1	0	0	0	0	0	0	1	0	0	1	2
17:45	0	0	0	0	0	0	2	0	0	2	0	0	0	0	0	0	2	0	0	2	4
Total Volume	0	0	0	0	0	0	5	0	0	5	0	0	0	0	0	0	6	0	0	6	11
% App. Total	0	0	0	0	0	0	100	0	0	100	0	0	0	0	0	0	100	0	0	100	
PHF	.000	.000	.000	.000	.000	.000	.625	.000	.000	.625	.000	.000	.000	.000	.000	.000	.500	.000	.000	.500	.688

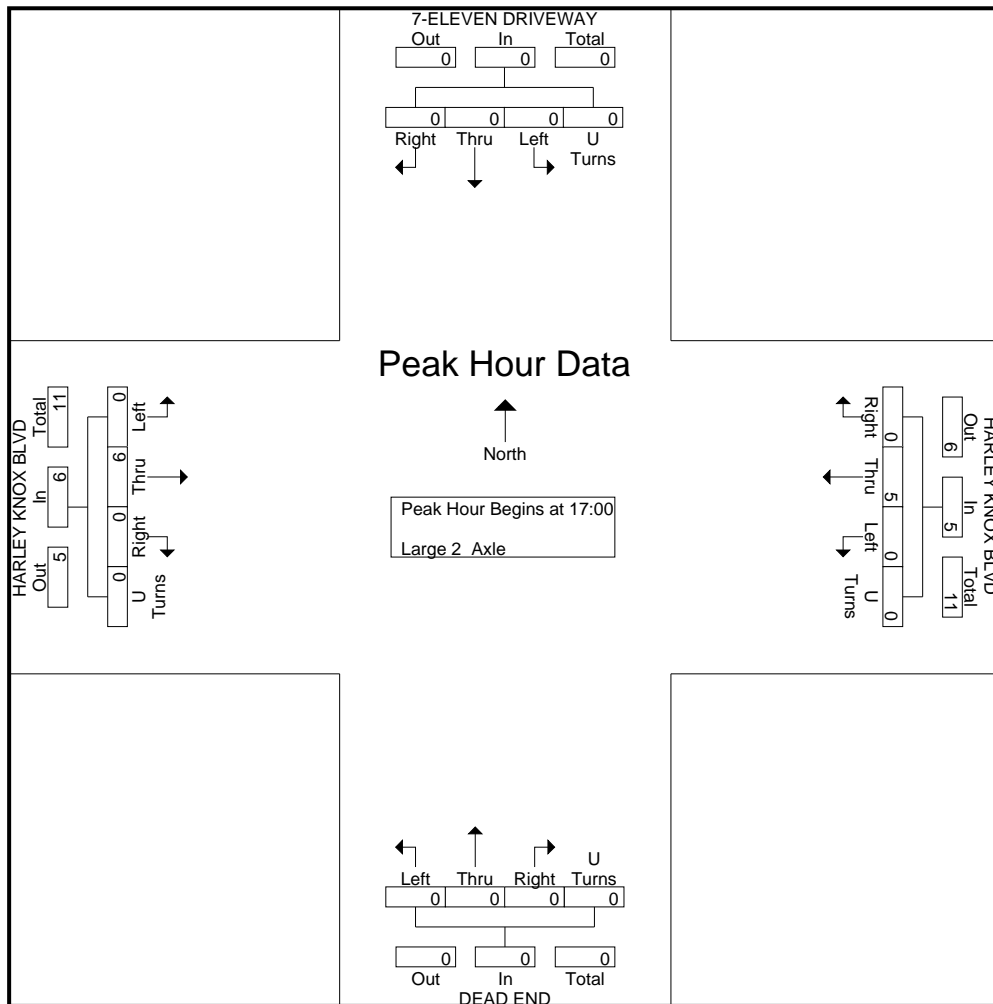

City: PERRIS
 N-S Direction: 7-ELEVEN DRIVEWAY
 E-W Direction: HARLEY KNOX BLVD

File Name : H2401001
 Site Code : 00000000
 Start Date : 1/9/2024
 Page No : 1

Groups Printed- Large 3 Axle

Start Time	7-ELEVEN DRIVEWAY Southbound				HARLEY KNOX BLVD Westbound				DEAD END Northbound				HARLEY KNOX BLVD Eastbound				Int. Total
	Right	Thru	Left	U Turns	Right	Thru	Left	U Turns	Right	Thru	Left	U Turns	Right	Thru	Left	U Turns	
07:00	0	0	0	0	0	2	0	0	0	0	0	0	0	2	0	0	4
07:15	0	0	0	0	0	2	0	0	0	0	0	0	0	0	0	0	2
07:30	0	0	0	0	1	2	0	0	0	0	0	0	0	2	0	0	5
07:45	0	0	0	0	0	3	0	0	0	0	0	0	0	1	0	0	4
Total	0	0	0	0	1	9	0	0	0	0	0	0	0	5	0	0	15
08:00	1	0	0	0	0	3	0	0	0	0	0	0	0	1	0	0	5
08:15	0	0	0	0	1	0	0	0	0	0	0	0	0	1	0	0	2
08:30	1	0	0	0	1	3	0	0	0	0	0	0	0	3	0	0	8
08:45	1	0	0	0	0	1	0	0	0	0	0	0	0	1	0	0	3
Total	3	0	0	0	2	7	0	0	0	0	0	0	0	6	0	0	18
16:00	0	0	0	0	0	3	0	0	0	0	0	0	0	1	0	0	4
16:15	0	0	0	0	0	2	0	0	0	0	0	0	0	2	0	0	4
16:30	0	0	0	0	0	2	0	0	0	0	0	0	0	1	0	0	3
16:45	0	0	0	0	0	3	0	0	0	0	0	0	0	2	0	0	5
Total	0	0	0	0	0	10	0	0	0	0	0	0	0	6	0	0	16
17:00	0	0	0	0	1	2	0	0	0	0	0	0	0	4	0	0	7
17:15	0	0	0	0	0	1	0	0	0	0	0	0	0	0	0	0	1
17:30	0	0	0	0	0	1	0	0	0	0	0	0	0	1	0	0	2
17:45	1	0	0	0	0	1	0	0	0	0	0	0	0	2	0	0	4
Total	1	0	0	0	1	5	0	0	0	0	0	0	0	7	0	0	14
Grand Total	4	0	0	0	4	31	0	0	0	0	0	0	0	24	0	0	63
Apprch %	100	0	0	0	11.4	88.6	0	0	0	0	0	0	0	100	0	0	
Total %	6.3	0	0	0	6.3	49.2	0	0	0	0	0	0	0	38.1	0	0	

City: PERRIS
 N-S Direction: 7-ELEVEN DRIVEWAY
 E-W Direction: HARLEY KNOX BLVD

File Name : H2401001
 Site Code : 0000000
 Start Date : 1/9/2024
 Page No : 2

Start Time	7-ELEVEN DRIVEWAY Southbound					HARLEY KNOX BLVD Westbound					DEAD END Northbound					HARLEY KNOX BLVD Eastbound					Int. Total
	Right	Thru	Left	U Turns	App. Total	Right	Thru	Left	U Turns	App. Total	Right	Thru	Left	U Turns	App. Total	Right	Thru	Left	U Turns	App. Total	
Peak Hour Analysis From 07:00 to 08:45 - Peak 1 of 1																					
Peak Hour for Entire Intersection Begins at 07:45																					
07:45	0	0	0	0	0	0	3	0	0	3	0	0	0	0	0	0	1	0	0	1	4
08:00	1	0	0	0	1	0	3	0	0	3	0	0	0	0	0	0	1	0	0	1	5
08:15	0	0	0	0	0	1	0	0	0	1	0	0	0	0	0	0	1	0	0	1	2
08:30	1	0	0	0	1	1	3	0	0	4	0	0	0	0	0	0	3	0	0	3	8
Total Volume	2	0	0	0	2	2	9	0	0	11	0	0	0	0	0	0	6	0	0	6	19
% App. Total	100	0	0	0		18.2	81.8	0	0		0	0	0	0		0	100	0	0		
PHF	.500	.000	.000	.000	.500	.500	.750	.000	.000	.688	.000	.000	.000	.000	.000	.000	.500	.000	.000	.500	.594

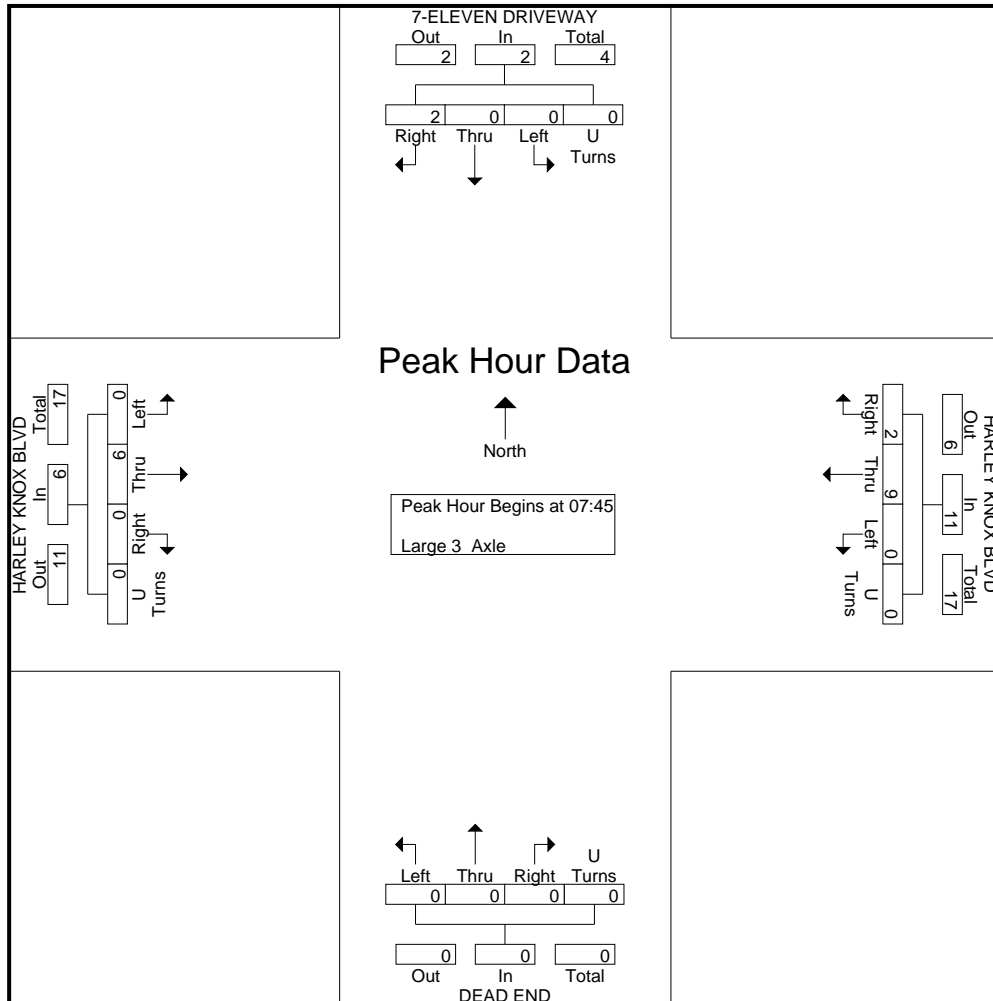

City: PERRIS
 N-S Direction: 7-ELEVEN DRIVEWAY
 E-W Direction: HARLEY KNOX BLVD

File Name : H2401001
 Site Code : 00000000
 Start Date : 1/9/2024
 Page No : 3

Start Time	7-ELEVEN DRIVEWAY Southbound					HARLEY KNOX BLVD Westbound					DEAD END Northbound					HARLEY KNOX BLVD Eastbound					Int. Total
	Right	Thru	Left	U Turns	App. Total	Right	Thru	Left	U Turns	App. Total	Right	Thru	Left	U Turns	App. Total	Right	Thru	Left	U Turns	App. Total	
Peak Hour Analysis From 16:00 to 17:45 - Peak 1 of 1																					
Peak Hour for Entire Intersection Begins at 16:15																					
16:15	0	0	0	0	0	0	2	0	0	2	0	0	0	0	0	0	2	0	0	2	4
16:30	0	0	0	0	0	0	2	0	0	2	0	0	0	0	0	0	1	0	0	1	3
16:45	0	0	0	0	0	0	3	0	0	3	0	0	0	0	0	0	2	0	0	2	5
17:00	0	0	0	0	0	1	2	0	0	3	0	0	0	0	0	0	4	0	0	4	7
Total Volume	0	0	0	0	0	1	9	0	0	10	0	0	0	0	0	0	9	0	0	9	19
% App. Total	0	0	0	0	0	10	90	0	0	100	0	0	0	0	0	0	100	0	0	100	100
PHF	.000	.000	.000	.000	.000	.250	.750	.000	.000	.833	.000	.000	.000	.000	.000	.000	.563	.000	.000	.563	.679

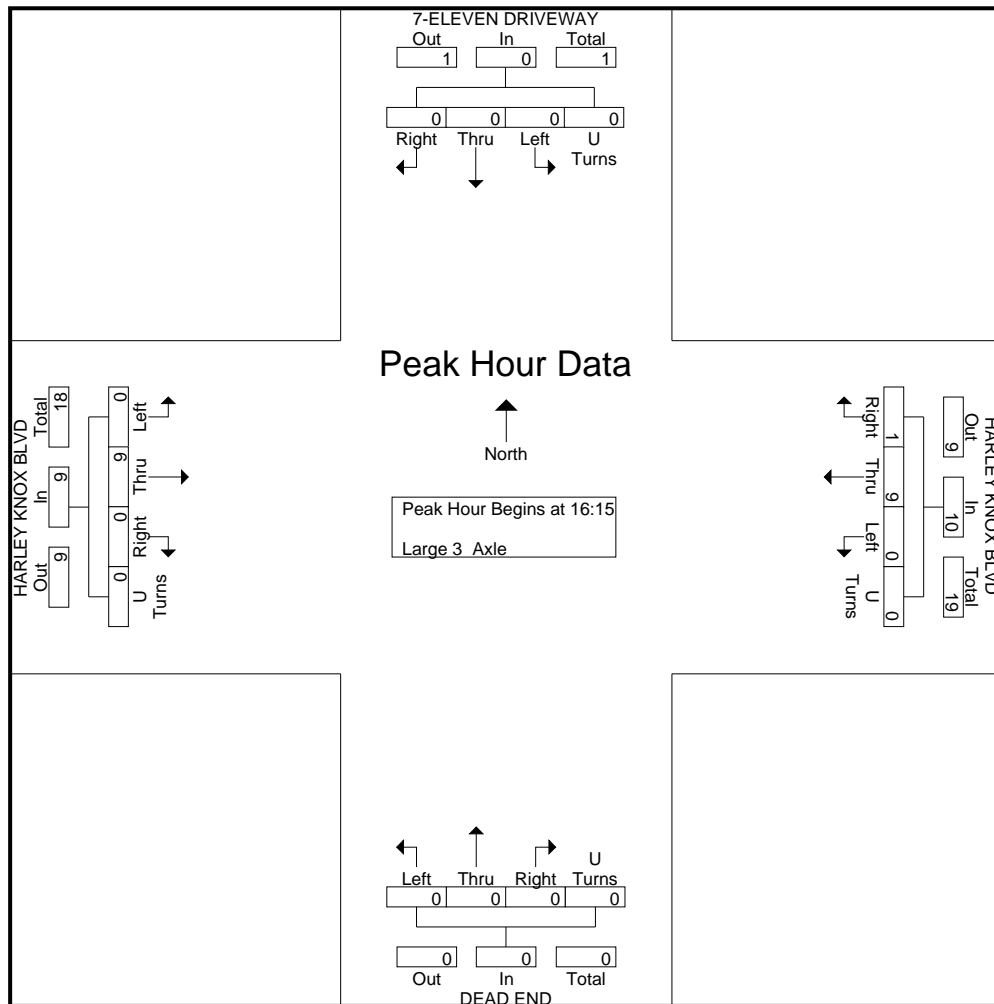

City: PERRIS
 N-S Direction: 7-ELEVEN DRIVEWAY
 E-W Direction: HARLEY KNOX BLVD

File Name : H2401001
 Site Code : 00000000
 Start Date : 1/9/2024
 Page No : 1

Groups Printed- Large 4+ Axle

Start Time	7-ELEVEN DRIVEWAY Southbound				HARLEY KNOX BLVD Westbound				DEAD END Northbound				HARLEY KNOX BLVD Eastbound				Int. Total
	Right	Thru	Left	U Turns	Right	Thru	Left	U Turns	Right	Thru	Left	U Turns	Right	Thru	Left	U Turns	
07:00	0	0	0	0	0	4	0	0	0	0	0	0	0	8	0	0	12
07:15	0	0	0	0	0	6	0	0	0	0	0	0	0	7	0	0	13
07:30	1	0	0	0	0	9	0	0	0	0	0	0	0	9	0	0	19
07:45	0	0	0	0	0	3	0	0	0	0	0	0	0	7	0	0	10
Total	1	0	0	0	0	22	0	0	0	0	0	0	0	31	0	0	54
08:00	0	0	0	0	0	8	0	0	0	0	0	0	0	5	0	0	13
08:15	0	0	0	0	0	9	0	0	0	0	0	0	0	7	0	0	16
08:30	0	0	0	0	0	6	0	0	0	0	0	0	0	7	0	0	13
08:45	0	0	0	0	0	10	0	0	0	0	0	0	0	10	0	0	20
Total	0	0	0	0	0	33	0	0	0	0	0	0	0	29	0	0	62
16:00	1	0	0	0	0	5	0	0	0	0	0	0	0	9	0	0	15
16:15	1	0	0	0	0	6	0	0	0	0	0	0	0	3	0	0	10
16:30	0	0	0	0	0	15	0	0	0	0	0	0	0	7	0	0	22
16:45	1	0	0	0	0	6	0	0	0	0	0	0	0	2	0	0	9
Total	3	0	0	0	0	32	0	0	0	0	0	0	0	21	0	0	56
17:00	0	0	0	0	0	8	0	0	0	0	0	0	0	3	0	0	11
17:15	0	0	0	0	0	7	0	0	0	0	0	0	0	2	0	0	9
17:30	0	0	0	0	0	1	0	0	0	0	0	0	0	5	0	0	6
17:45	0	0	0	0	0	10	0	0	0	0	0	0	0	5	0	0	15
Total	0	0	0	0	0	26	0	0	0	0	0	0	0	15	0	0	41
Grand Total	4	0	0	0	0	113	0	0	0	0	0	0	0	96	0	0	213
Apprch %	100	0	0	0	0	100	0	0	0	0	0	0	0	100	0	0	
Total %	1.9	0	0	0	0	53.1	0	0	0	0	0	0	0	45.1	0	0	

City: PERRIS
 N-S Direction: 7-ELEVEN DRIVEWAY
 E-W Direction: HARLEY KNOX BLVD

File Name : H2401001
 Site Code : 0000000
 Start Date : 1/9/2024
 Page No : 2

Start Time	7-ELEVEN DRIVEWAY Southbound					HARLEY KNOX BLVD Westbound					DEAD END Northbound					HARLEY KNOX BLVD Eastbound					Int. Total
	Right	Thru	Left	U Turns	App. Total	Right	Thru	Left	U Turns	App. Total	Right	Thru	Left	U Turns	App. Total	Right	Thru	Left	U Turns	App. Total	
Peak Hour Analysis From 07:00 to 08:45 - Peak 1 of 1																					
Peak Hour for Entire Intersection Begins at 08:00																					
08:00	0	0	0	0	0	0	8	0	0	8	0	0	0	0	0	0	5	0	0	5	13
08:15	0	0	0	0	0	0	9	0	0	9	0	0	0	0	0	0	7	0	0	7	16
08:30	0	0	0	0	0	0	6	0	0	6	0	0	0	0	0	0	7	0	0	7	13
08:45	0	0	0	0	0	0	10	0	0	10	0	0	0	0	0	0	10	0	0	10	20
Total Volume	0	0	0	0	0	0	33	0	0	33	0	0	0	0	0	0	29	0	0	29	62
% App. Total	0	0	0	0	0	0	100	0	0	100	0	0	0	0	0	0	100	0	0	100	100
PHF	.000	.000	.000	.000	.000	.000	.825	.000	.000	.825	.000	.000	.000	.000	.000	.000	.725	.000	.000	.725	.775

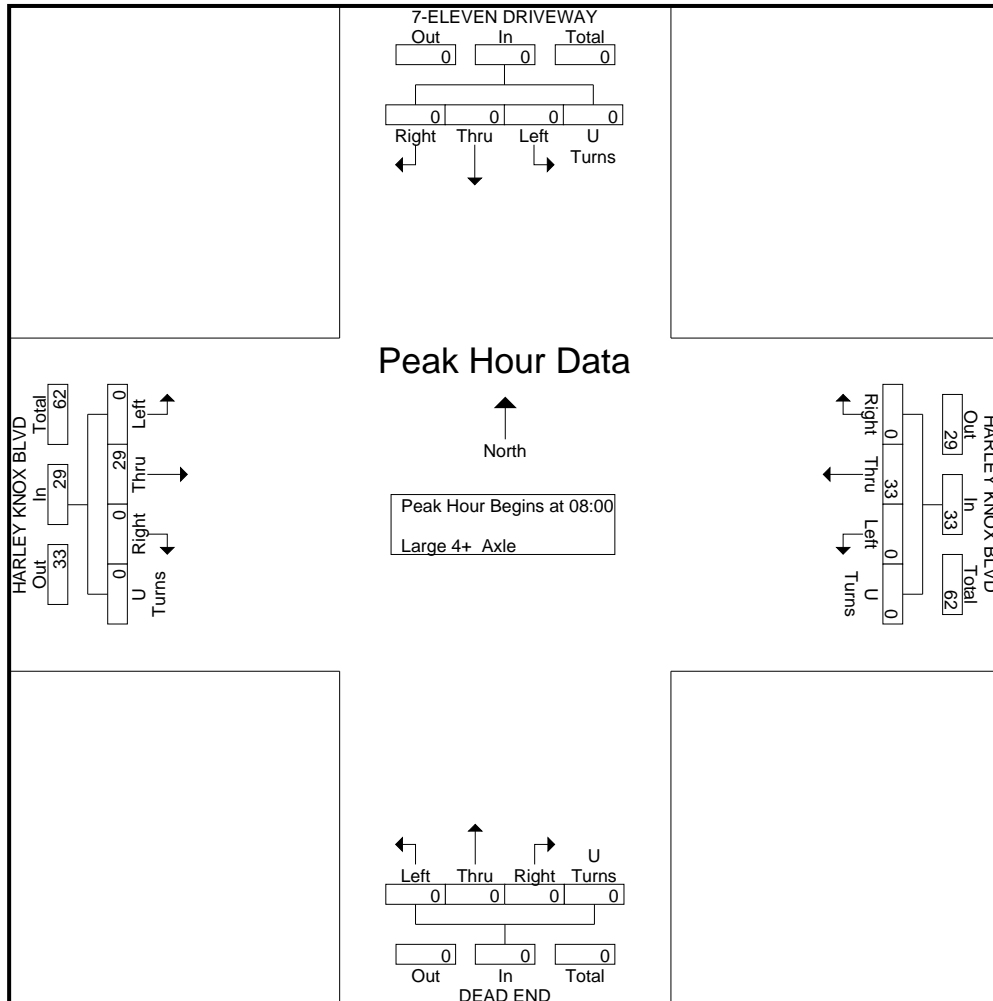

City: PERRIS
 N-S Direction: 7-ELEVEN DRIVEWAY
 E-W Direction: HARLEY KNOX BLVD

File Name : H2401001
 Site Code : 0000000
 Start Date : 1/9/2024
 Page No : 3

Start Time	7-ELEVEN DRIVEWAY Southbound					HARLEY KNOX BLVD Westbound					DEAD END Northbound					HARLEY KNOX BLVD Eastbound					Int. Total
	Right	Thru	Left	U Turns	App. Total	Right	Thru	Left	U Turns	App. Total	Right	Thru	Left	U Turns	App. Total	Right	Thru	Left	U Turns	App. Total	
Peak Hour Analysis From 16:00 to 17:45 - Peak 1 of 1																					
Peak Hour for Entire Intersection Begins at 16:00																					
16:00	1	0	0	0	1	0	5	0	0	5	0	0	0	0	0	0	9	0	0	9	15
16:15	1	0	0	0	1	0	6	0	0	6	0	0	0	0	0	0	3	0	0	3	10
16:30	0	0	0	0	0	0	15	0	0	15	0	0	0	0	0	0	7	0	0	7	22
16:45	1	0	0	0	1	0	6	0	0	6	0	0	0	0	0	0	2	0	0	2	9
Total Volume	3	0	0	0	3	0	32	0	0	32	0	0	0	0	0	0	21	0	0	21	56
% App. Total	100	0	0	0		0	100	0	0		0	0	0	0		0	100	0	0		
PHF	.750	.000	.000	.000	.750	.000	.533	.000	.000	.533	.000	.000	.000	.000	.000	.000	.583	.000	.000	.583	.636

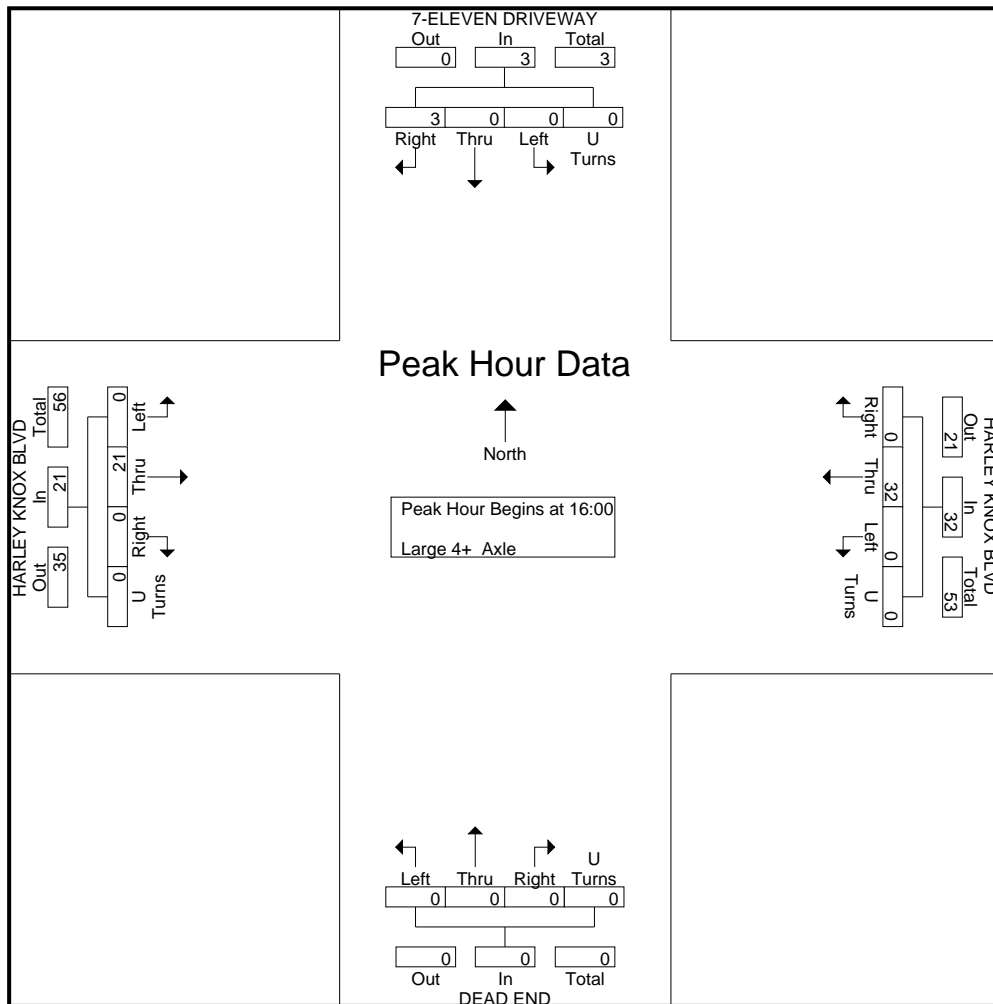

City: PERRIS
 N-S Direction: NATIONAL TRANSPORT
 E-W Direction: HARLEY KNOX BLVD

File Name : H2401002
 Site Code : 00000000
 Start Date : 1/9/2024
 Page No : 1

Groups Printed- Vehicles

Start Time	NATIONAL TRANSPORT Southbound				HARLEY KNOX BLVD Westbound				DEAD END Northbound				HARLEY KNOX BLVD Eastbound				Int. Total
	Right	Thru	Left	U Turns	Right	Thru	Left	U Turns	Right	Thru	Left	U Turns	Right	Thru	Left	U Turns	
07:00	0	0	0	0	0	147	0	0	0	0	0	0	0	35	5	0	187
07:15	0	0	1	0	0	169	0	0	0	0	0	0	0	23	0	0	193
07:30	0	0	0	0	4	127	0	0	0	0	0	0	0	25	0	0	156
07:45	0	0	0	0	3	144	0	0	0	0	0	0	0	44	0	0	191
Total	0	0	1	0	7	587	0	0	0	0	0	0	0	127	5	0	727
08:00	0	0	0	0	0	67	0	0	0	0	0	0	0	29	0	0	96
08:15	0	0	0	0	0	83	0	0	0	0	0	0	0	41	2	0	126
08:30	0	0	0	0	0	65	0	0	0	0	0	0	0	37	0	0	102
08:45	0	0	0	0	1	40	0	0	0	0	0	0	0	35	1	0	77
Total	0	0	0	0	1	255	0	0	0	0	0	0	0	142	3	0	401
16:00	1	0	2	0	0	81	0	1	0	0	0	0	0	84	4	0	173
16:15	3	0	2	0	1	74	0	2	0	0	0	0	0	80	1	0	163
16:30	3	0	0	0	0	97	0	0	0	0	0	0	0	121	5	0	226
16:45	1	0	0	0	0	72	0	0	0	0	0	0	0	85	1	0	159
Total	8	0	4	0	1	324	0	3	0	0	0	0	0	370	11	0	721
17:00	0	0	1	0	0	49	0	0	0	0	0	0	0	93	3	0	146
17:15	0	0	0	0	1	56	0	0	0	0	0	0	0	79	1	0	137
17:30	0	0	0	0	1	77	0	0	0	0	0	0	0	98	2	0	178
17:45	0	0	1	0	0	44	0	0	0	0	0	0	0	66	3	0	114
Total	0	0	2	0	2	226	0	0	0	0	0	0	0	336	9	0	575
Grand Total	8	0	7	0	11	1392	0	3	0	0	0	0	0	975	28	0	2424
Apprch %	53.3	0	46.7	0	0.8	99	0	0.2	0	0	0	0	0	97.2	2.8	0	
Total %	0.3	0	0.3	0	0.5	57.4	0	0.1	0	0	0	0	0	40.2	1.2	0	

City: PERRIS
 N-S Direction: NATIONAL TRANSPORT
 E-W Direction: HARLEY KNOX BLVD

File Name : H2401002
 Site Code : 0000000
 Start Date : 1/9/2024
 Page No : 2

Start Time	NATIONAL TRANSPORT Southbound					HARLEY KNOX BLVD Westbound					DEAD END Northbound					HARLEY KNOX BLVD Eastbound					Int. Total
	Right	Thru	Left	U Turns	App. Total	Right	Thru	Left	U Turns	App. Total	Right	Thru	Left	U Turns	App. Total	Right	Thru	Left	U Turns	App. Total	
Peak Hour Analysis From 07:00 to 08:45 - Peak 1 of 1																					
Peak Hour for Entire Intersection Begins at 07:00																					
07:00	0	0	0	0	0	0	147	0	0	147	0	0	0	0	0	0	35	5	0	40	187
07:15	0	0	1	0	1	0	169	0	0	169	0	0	0	0	0	0	23	0	0	23	193
07:30	0	0	0	0	0	4	127	0	0	131	0	0	0	0	0	0	25	0	0	25	156
07:45	0	0	0	0	0	3	144	0	0	147	0	0	0	0	0	0	44	0	0	44	191
Total Volume	0	0	1	0	1	7	587	0	0	594	0	0	0	0	0	0	127	5	0	132	727
% App. Total	0	0	100	0		1.2	98.8	0	0		0	0	0	0		0	96.2	3.8	0		
PHF	.000	.000	.250	.000	.250	.438	.868	.000	.000	.879	.000	.000	.000	.000	.000	.000	.722	.250	.000	.750	.942

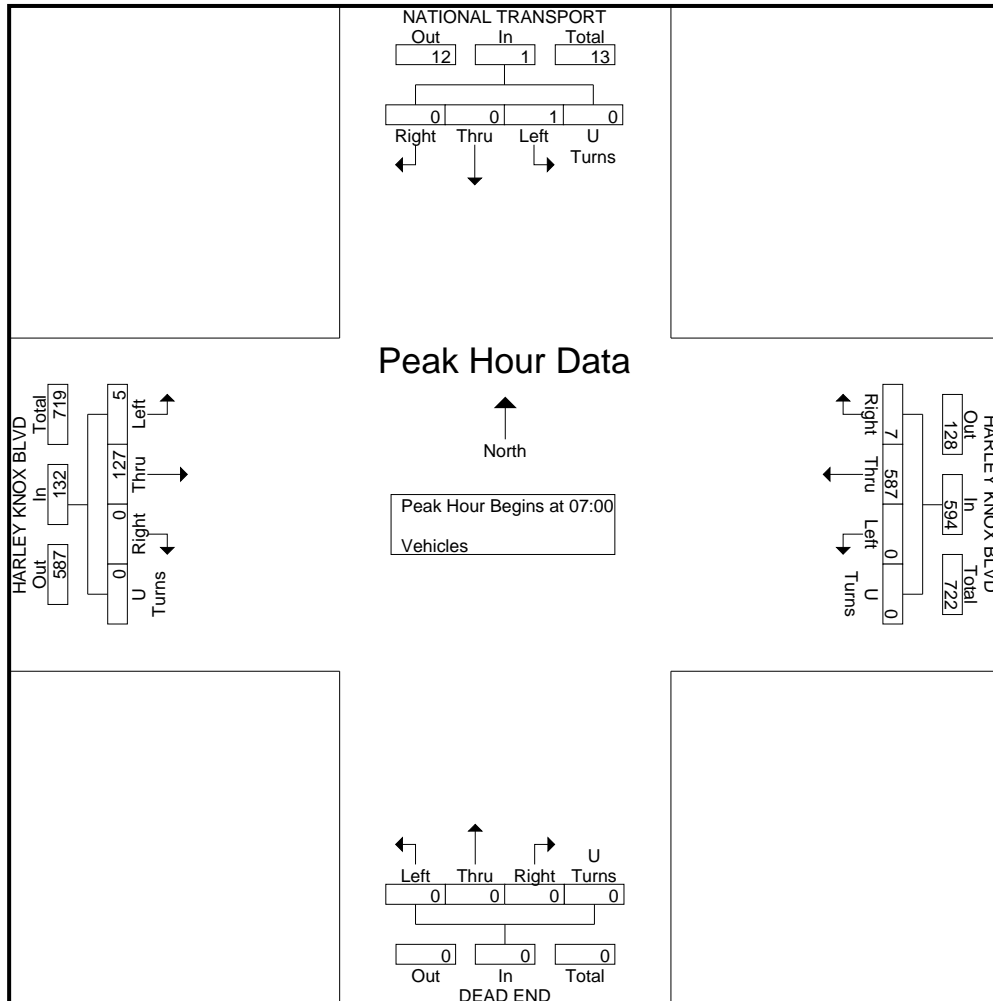

City: PERRIS
 N-S Direction: NATIONAL TRANSPORT
 E-W Direction: HARLEY KNOX BLVD

File Name : H2401002
 Site Code : 0000000
 Start Date : 1/9/2024
 Page No : 3

Start Time	NATIONAL TRANSPORT Southbound					HARLEY KNOX BLVD Westbound					DEAD END Northbound					HARLEY KNOX BLVD Eastbound					Int. Total
	Right	Thru	Left	U Turns	App. Total	Right	Thru	Left	U Turns	App. Total	Right	Thru	Left	U Turns	App. Total	Right	Thru	Left	U Turns	App. Total	
Peak Hour Analysis From 16:00 to 17:45 - Peak 1 of 1																					
Peak Hour for Entire Intersection Begins at 16:00																					
16:00	1	0	2	0	3	0	81	0	1	82	0	0	0	0	0	0	84	4	0	88	173
16:15	3	0	2	0	5	1	74	0	2	77	0	0	0	0	0	0	80	1	0	81	163
16:30	3	0	0	0	3	0	97	0	0	97	0	0	0	0	0	0	121	5	0	126	226
16:45	1	0	0	0	1	0	72	0	0	72	0	0	0	0	0	0	85	1	0	86	159
Total Volume	8	0	4	0	12	1	324	0	3	328	0	0	0	0	0	0	370	11	0	381	721
% App. Total	66.7	0	33.3	0		0.3	98.8	0	0.9		0	0	0	0		0	97.1	2.9	0		
PHF	.667	.000	.500	.000	.600	.250	.835	.000	.375	.845	.000	.000	.000	.000	.000	.000	.764	.550	.000	.756	.798

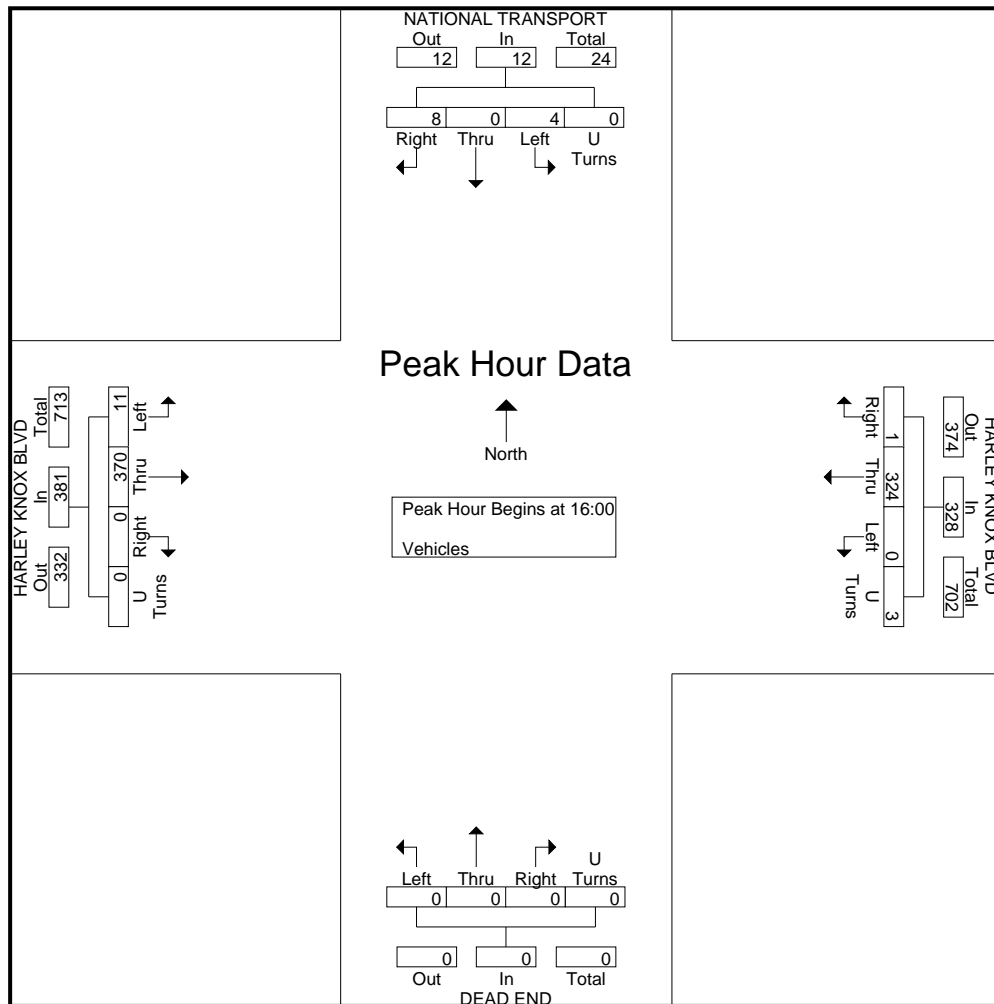

City: PERRIS
 N-S Direction: NATIONAL TRANSPORT
 E-W Direction: HARLEY KNOX BLVD

File Name : H2401002
 Site Code : 00000000
 Start Date : 1/9/2024
 Page No : 1

Groups Printed- Large 2 Axle

Start Time	NATIONAL TRANSPORT Southbound				HARLEY KNOX BLVD Westbound				DEAD END Northbound				HARLEY KNOX BLVD Eastbound				Int. Total
	Right	Thru	Left	U Turns	Right	Thru	Left	U Turns	Right	Thru	Left	U Turns	Right	Thru	Left	U Turns	
07:00	0	0	0	0	0	2	0	0	0	0	0	0	0	0	0	0	2
07:15	0	0	0	0	0	2	0	0	0	0	0	0	0	1	0	0	3
07:30	0	0	0	0	0	3	0	0	0	0	0	0	0	1	0	0	4
07:45	0	0	0	0	0	1	0	0	0	0	0	0	0	3	0	0	4
Total	0	0	0	0	0	8	0	0	0	0	0	0	0	5	0	0	13
08:00	0	0	0	0	0	1	0	0	0	0	0	0	0	0	0	0	1
08:15	0	0	0	0	0	1	0	0	0	0	0	0	0	2	0	0	3
08:30	0	0	0	0	1	4	0	0	0	0	0	0	0	0	0	0	5
08:45	0	0	0	0	0	0	0	0	0	0	0	0	0	3	1	0	4
Total	0	0	0	0	1	6	0	0	0	0	0	0	0	5	1	0	13
16:15	0	0	0	0	0	0	0	0	0	0	0	0	0	1	1	0	2
16:45	0	0	0	0	0	0	0	0	0	0	0	0	0	1	0	0	1
Total	0	0	0	0	0	0	0	0	0	0	0	0	0	2	1	0	3
17:00	0	0	0	0	0	1	0	0	0	0	0	0	0	2	2	0	5
17:30	0	0	0	0	0	2	0	0	0	0	0	0	0	2	0	0	4
17:45	0	0	0	0	0	2	0	0	0	0	0	0	0	1	2	0	5
Total	0	0	0	0	0	5	0	0	0	0	0	0	0	5	4	0	14
Grand Total	0	0	0	0	1	19	0	0	0	0	0	0	0	17	6	0	43
Apprch %	0	0	0	0	5	95	0	0	0	0	0	0	0	73.9	26.1	0	
Total %	0	0	0	0	2.3	44.2	0	0	0	0	0	0	0	39.5	14	0	

City: PERRIS
 N-S Direction: NATIONAL TRANSPORT
 E-W Direction: HARLEY KNOX BLVD

File Name : H2401002
 Site Code : 0000000
 Start Date : 1/9/2024
 Page No : 2

Start Time	NATIONAL TRANSPORT Southbound					HARLEY KNOX BLVD Westbound					DEAD END Northbound					HARLEY KNOX BLVD Eastbound					Int. Total
	Right	Thru	Left	U Turns	App. Total	Right	Thru	Left	U Turns	App. Total	Right	Thru	Left	U Turns	App. Total	Right	Thru	Left	U Turns	App. Total	
Peak Hour Analysis From 07:00 to 08:45 - Peak 1 of 1																					
Peak Hour for Entire Intersection Begins at 07:00																					
07:00	0	0	0	0	0	0	2	0	0	2	0	0	0	0	0	0	0	0	0	0	0
07:15	0	0	0	0	0	0	2	0	0	2	0	0	0	0	0	0	1	0	0	1	3
07:30	0	0	0	0	0	0	3	0	0	3	0	0	0	0	0	0	1	0	0	1	4
07:45	0	0	0	0	0	0	1	0	0	1	0	0	0	0	0	0	3	0	0	3	4
Total Volume	0	0	0	0	0	0	8	0	0	8	0	0	0	0	0	0	5	0	0	5	13
% App. Total	0	0	0	0	0	0	100	0	0	0	0	0	0	0	0	0	100	0	0	0	
PHF	.000	.000	.000	.000	.000	.000	.667	.000	.000	.667	.000	.000	.000	.000	.000	.000	.417	.000	.000	.417	.813

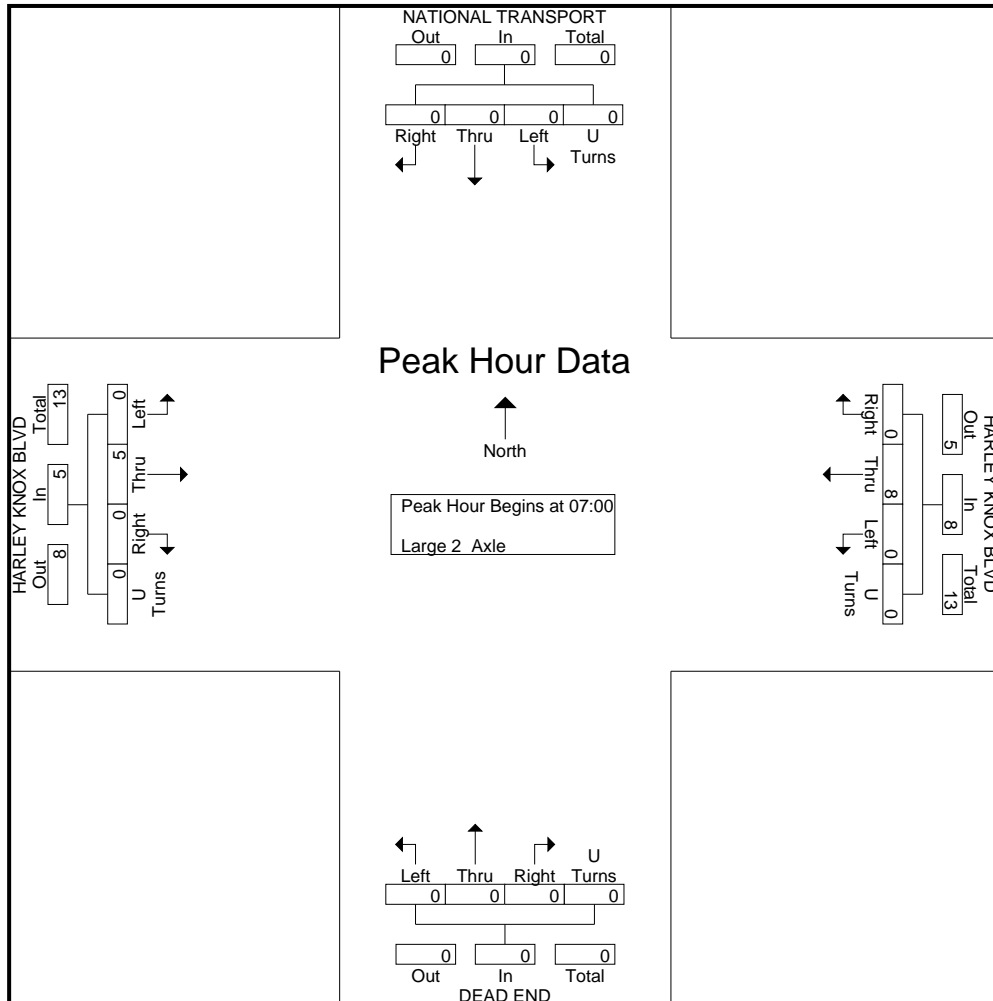

City: PERRIS
 N-S Direction: NATIONAL TRANSPORT
 E-W Direction: HARLEY KNOX BLVD

File Name : H2401002
 Site Code : 0000000
 Start Date : 1/9/2024
 Page No : 3

Start Time	NATIONAL TRANSPORT Southbound					HARLEY KNOX BLVD Westbound					DEAD END Northbound					HARLEY KNOX BLVD Eastbound					Int. Total
	Right	Thru	Left	U Turns	App. Total	Right	Thru	Left	U Turns	App. Total	Right	Thru	Left	U Turns	App. Total	Right	Thru	Left	U Turns	App. Total	
Peak Hour Analysis From 16:00 to 17:45 - Peak 1 of 1																					
Peak Hour for Entire Intersection Begins at 17:00																					
17:00	0	0	0	0	0	0	1	0	0	1	0	0	0	0	0	0	2	2	0	4	5
17:15	0	0	0	0	0	0	0	0	0	0	0	0	0	0	0	0	0	0	0	0	0
17:30	0	0	0	0	0	0	2	0	0	2	0	0	0	0	0	0	2	0	0	2	4
17:45	0	0	0	0	0	0	2	0	0	2	0	0	0	0	0	0	1	2	0	3	5
Total Volume	0	0	0	0	0	0	5	0	0	5	0	0	0	0	0	0	5	4	0	9	14
% App. Total	0	0	0	0	0	0	100	0	0	100	0	0	0	0	0	0	55.6	44.4	0	0	
PHF	.000	.000	.000	.000	.000	.000	.625	.000	.000	.625	.000	.000	.000	.000	.000	.000	.625	.500	.000	.563	.700

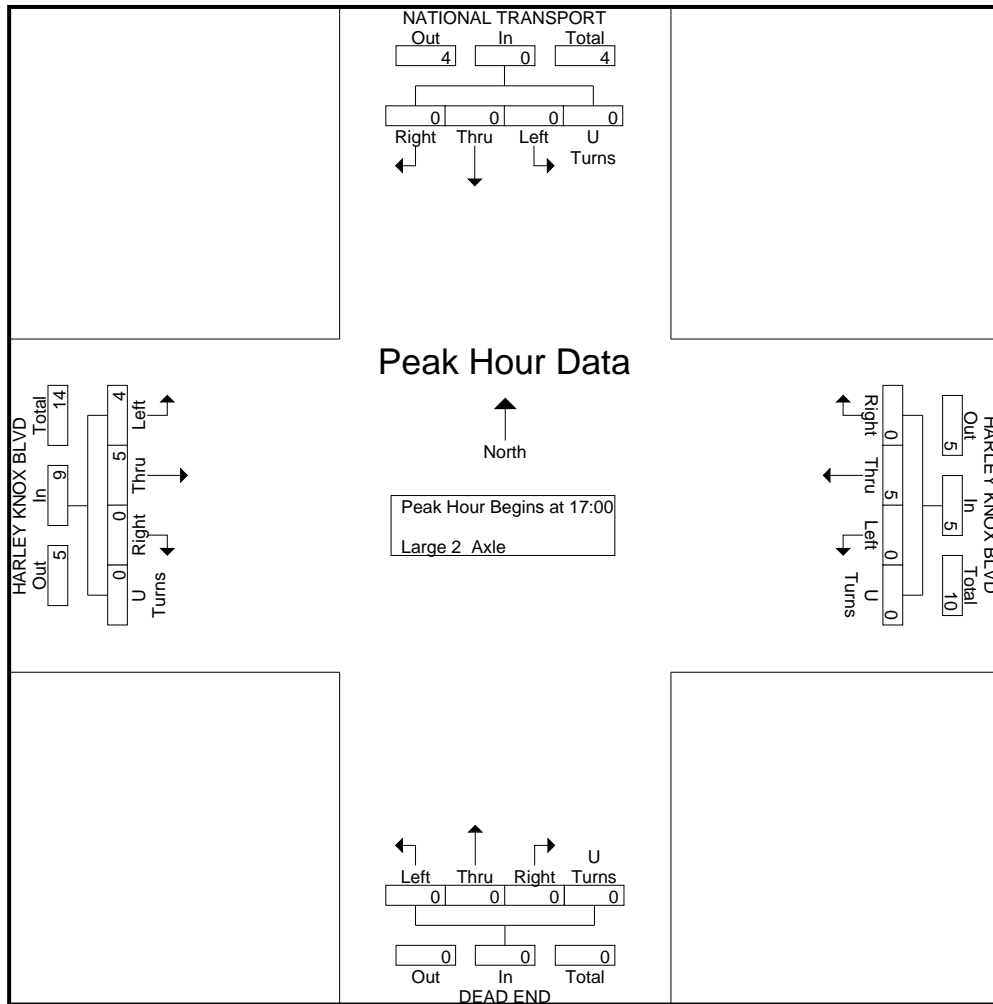

City: PERRIS
 N-S Direction: NATIONAL TRANSPORT
 E-W Direction: HARLEY KNOX BLVD

File Name : H2401002
 Site Code : 00000000
 Start Date : 1/9/2024
 Page No : 1

Groups Printed- Large 3 Axle

Start Time	NATIONAL TRANSPORT Southbound				HARLEY KNOX BLVD Westbound				DEAD END Northbound				HARLEY KNOX BLVD Eastbound				Int. Total
	Right	Thru	Left	U Turns	Right	Thru	Left	U Turns	Right	Thru	Left	U Turns	Right	Thru	Left	U Turns	
07:00	0	0	0	0	1	2	0	0	0	0	0	0	0	0	0	0	3
07:15	0	0	0	0	0	1	0	0	0	0	0	0	0	3	0	0	4
07:30	0	0	0	0	0	2	0	0	0	0	0	0	0	2	0	0	4
07:45	0	0	0	0	0	3	0	0	0	0	0	0	0	1	0	0	4
Total	0	0	0	0	1	8	0	0	0	0	0	0	0	6	0	0	15
08:00	0	0	0	0	0	4	0	0	0	0	0	0	0	0	1	0	5
08:15	0	0	0	0	0	0	0	0	0	0	0	0	0	1	0	0	1
08:30	0	0	0	0	0	4	0	0	0	0	0	0	0	4	0	0	8
08:45	0	0	0	0	0	1	0	0	0	0	0	0	0	1	0	0	2
Total	0	0	0	0	0	9	0	0	0	0	0	0	0	6	1	0	16
16:00	3	0	0	0	0	4	0	0	0	0	0	0	0	0	1	0	8
16:15	0	0	0	0	0	1	0	0	0	0	0	0	0	2	0	0	3
16:30	0	0	0	0	0	1	0	0	0	0	0	0	0	2	1	0	4
16:45	2	0	0	0	0	4	0	0	0	0	0	0	0	2	0	0	8
Total	5	0	0	0	0	10	0	0	0	0	0	0	0	6	2	0	23
17:00	1	0	0	0	0	0	0	0	0	0	0	0	0	3	0	0	4
17:15	1	0	0	0	2	2	0	0	0	0	0	0	0	0	0	0	5
17:30	0	0	0	0	0	0	0	0	0	0	0	0	0	0	1	0	1
17:45	0	0	0	0	0	2	0	0	0	0	0	0	0	3	1	0	6
Total	2	0	0	0	2	4	0	0	0	0	0	0	0	6	2	0	16
Grand Total	7	0	0	0	3	31	0	0	0	0	0	0	0	24	5	0	70
Apprch %	100	0	0	0	8.8	91.2	0	0	0	0	0	0	0	82.8	17.2	0	
Total %	10	0	0	0	4.3	44.3	0	0	0	0	0	0	0	34.3	7.1	0	

City: PERRIS
 N-S Direction: NATIONAL TRANSPORT
 E-W Direction: HARLEY KNOX BLVD

File Name : H2401002
 Site Code : 0000000
 Start Date : 1/9/2024
 Page No : 2

Start Time	NATIONAL TRANSPORT Southbound					HARLEY KNOX BLVD Westbound					DEAD END Northbound					HARLEY KNOX BLVD Eastbound					Int. Total
	Right	Thru	Left	U Turns	App. Total	Right	Thru	Left	U Turns	App. Total	Right	Thru	Left	U Turns	App. Total	Right	Thru	Left	U Turns	App. Total	
Peak Hour Analysis From 07:00 to 08:45 - Peak 1 of 1																					
Peak Hour for Entire Intersection Begins at 07:45																					
07:45	0	0	0	0	0	0	3	0	0	3	0	0	0	0	0	0	1	0	0	1	4
08:00	0	0	0	0	0	0	4	0	0	4	0	0	0	0	0	0	0	1	0	1	5
08:15	0	0	0	0	0	0	0	0	0	0	0	0	0	0	0	0	1	0	0	1	1
08:30	0	0	0	0	0	0	4	0	0	4	0	0	0	0	0	0	4	0	0	4	8
Total Volume	0	0	0	0	0	0	11	0	0	11	0	0	0	0	0	0	6	1	0	7	18
% App. Total	0	0	0	0	0	0	100	0	0	0	0	0	0	0	0	0	85.7	14.3	0	0	
PHF	.000	.000	.000	.000	.000	.000	.688	.000	.000	.688	.000	.000	.000	.000	.000	.000	.375	.250	.000	.438	.563

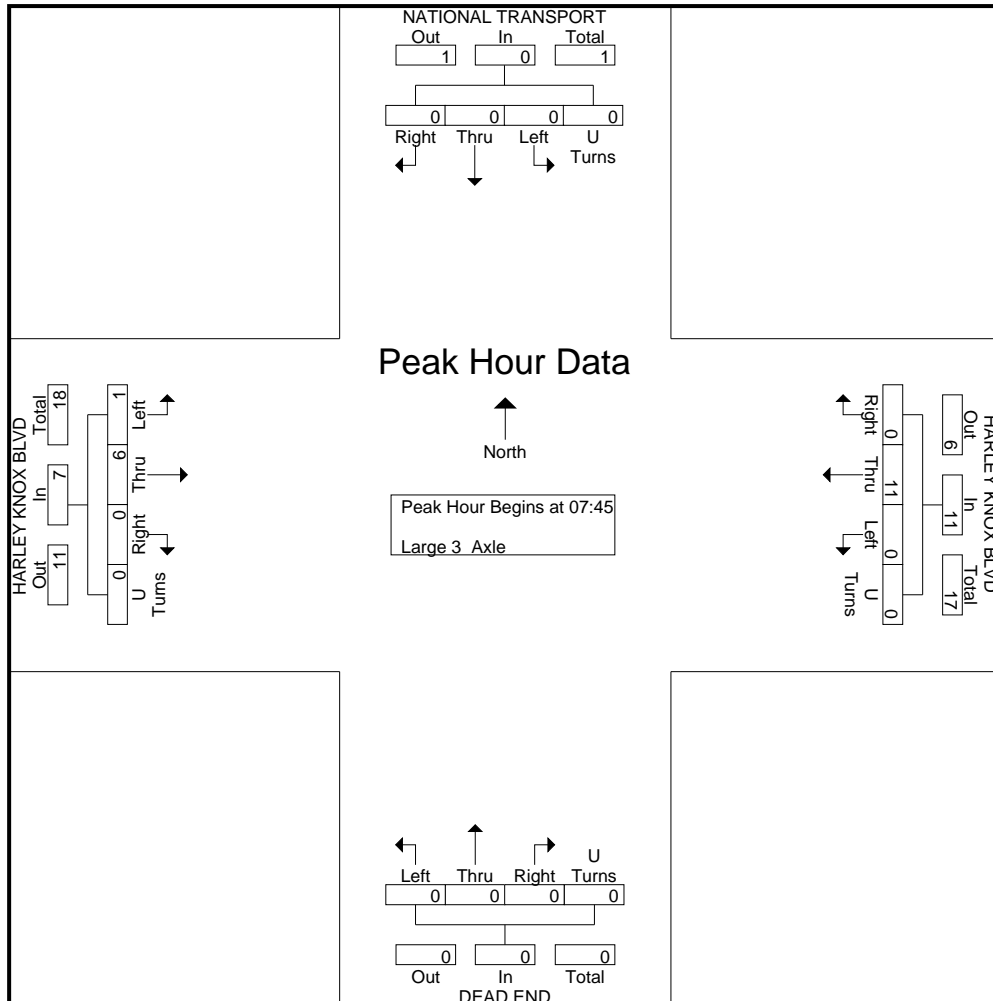

City: PERRIS
 N-S Direction: NATIONAL TRANSPORT
 E-W Direction: HARLEY KNOX BLVD

File Name : H2401002
 Site Code : 0000000
 Start Date : 1/9/2024
 Page No : 3

Start Time	NATIONAL TRANSPORT Southbound					HARLEY KNOX BLVD Westbound					DEAD END Northbound					HARLEY KNOX BLVD Eastbound					Int. Total
	Right	Thru	Left	U Turns	App. Total	Right	Thru	Left	U Turns	App. Total	Right	Thru	Left	U Turns	App. Total	Right	Thru	Left	U Turns	App. Total	
Peak Hour Analysis From 16:00 to 17:45 - Peak 1 of 1																					
Peak Hour for Entire Intersection Begins at 16:00																					
16:00	3	0	0	0	3	0	4	0	0	4	0	0	0	0	0	0	0	1	0	1	8
16:15	0	0	0	0	0	0	1	0	0	1	0	0	0	0	0	0	2	0	0	2	3
16:30	0	0	0	0	0	0	1	0	0	1	0	0	0	0	0	0	2	1	0	3	4
16:45	2	0	0	0	2	0	4	0	0	4	0	0	0	0	0	0	2	0	0	2	8
Total Volume	5	0	0	0	5	0	10	0	0	10	0	0	0	0	0	0	6	2	0	8	23
% App. Total	100	0	0	0		0	100	0	0		0	0	0	0		0	75	25	0		
PHF	.417	.000	.000	.000	.417	.000	.625	.000	.000	.625	.000	.000	.000	.000	.000	.000	.750	.500	.000	.667	.719

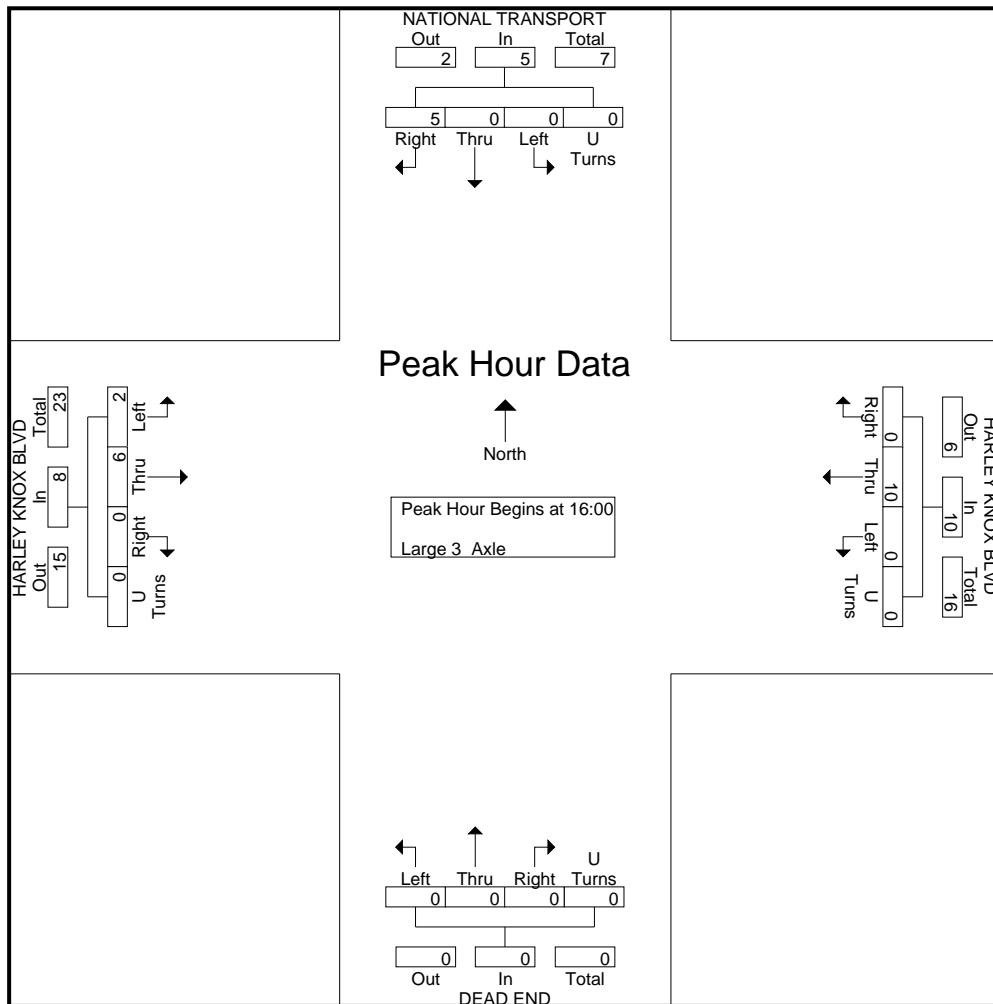

City: PERRIS
 N-S Direction: NATIONAL TRANSPORT
 E-W Direction: HARLEY KNOX BLVD

File Name : H2401002
 Site Code : 00000000
 Start Date : 1/9/2024
 Page No : 1

Groups Printed- Large 4+ Axle

Start Time	NATIONAL TRANSPORT Southbound				HARLEY KNOX BLVD Westbound				DEAD END Northbound				HARLEY KNOX BLVD Eastbound				Int. Total
	Right	Thru	Left	U Turns	Right	Thru	Left	U Turns	Right	Thru	Left	U Turns	Right	Thru	Left	U Turns	
07:00	1	0	0	0	0	4	0	0	0	0	0	0	0	9	0	0	14
07:15	0	0	0	0	0	6	0	0	0	0	0	0	0	7	0	0	13
07:30	0	0	0	0	0	10	0	0	0	0	0	0	0	9	1	0	20
07:45	1	0	0	0	0	3	0	0	0	0	0	0	0	8	0	0	12
Total	2	0	0	0	0	23	0	0	0	0	0	0	0	33	1	0	59
08:00	1	0	0	0	0	8	0	0	0	0	0	0	0	6	0	0	15
08:15	1	0	0	0	0	9	0	0	0	0	0	0	0	8	2	0	20
08:30	0	0	0	0	1	5	0	0	0	0	0	0	0	9	0	0	15
08:45	0	0	0	0	0	10	0	0	0	0	0	0	0	6	0	0	16
Total	2	0	0	0	1	32	0	0	0	0	0	0	0	29	2	0	66
16:00	0	0	0	0	0	5	0	0	0	0	0	0	0	10	0	0	15
16:15	0	0	0	0	0	8	0	0	0	0	0	0	0	3	1	0	12
16:30	2	0	0	0	0	14	0	0	0	0	0	0	0	7	1	0	24
16:45	1	0	0	0	0	5	0	0	0	0	0	0	0	2	1	0	9
Total	3	0	0	0	0	32	0	0	0	0	0	0	0	22	3	0	60
17:00	1	0	0	0	0	9	0	0	0	0	0	0	0	4	1	0	15
17:15	0	0	0	0	0	5	0	0	0	0	0	0	0	2	0	0	7
17:30	2	0	0	0	0	2	0	0	0	0	0	0	0	6	0	0	10
17:45	1	0	0	0	2	7	0	0	0	0	0	0	0	5	1	0	16
Total	4	0	0	0	2	23	0	0	0	0	0	0	0	17	2	0	48
Grand Total	11	0	0	0	3	110	0	0	0	0	0	0	0	101	8	0	233
Apprch %	100	0	0	0	2.7	97.3	0	0	0	0	0	0	0	92.7	7.3	0	
Total %	4.7	0	0	0	1.3	47.2	0	0	0	0	0	0	0	43.3	3.4	0	

City: PERRIS
 N-S Direction: NATIONAL TRANSPORT
 E-W Direction: HARLEY KNOX BLVD

File Name : H2401002
 Site Code : 0000000
 Start Date : 1/9/2024
 Page No : 2

Start Time	NATIONAL TRANSPORT Southbound					HARLEY KNOX BLVD Westbound					DEAD END Northbound					HARLEY KNOX BLVD Eastbound					Int. Total
	Right	Thru	Left	U Turns	App. Total	Right	Thru	Left	U Turns	App. Total	Right	Thru	Left	U Turns	App. Total	Right	Thru	Left	U Turns	App. Total	
Peak Hour Analysis From 07:00 to 08:45 - Peak 1 of 1																					
Peak Hour for Entire Intersection Begins at 07:30																					
07:30	0	0	0	0	0	0	10	0	0	10	0	0	0	0	0	0	9	1	0	10	20
07:45	1	0	0	0	1	0	3	0	0	3	0	0	0	0	0	0	8	0	0	8	12
08:00	1	0	0	0	1	0	8	0	0	8	0	0	0	0	0	0	6	0	0	6	15
08:15	1	0	0	0	1	0	9	0	0	9	0	0	0	0	0	0	8	2	0	10	20
Total Volume	3	0	0	0	3	0	30	0	0	30	0	0	0	0	0	0	31	3	0	34	67
% App. Total	100	0	0	0		0	100	0	0		0	0	0	0		0	91.2	8.8	0		
PHF	.750	.000	.000	.000	.750	.000	.750	.000	.000	.750	.000	.000	.000	.000	.000	.000	.861	.375	.000	.850	.838

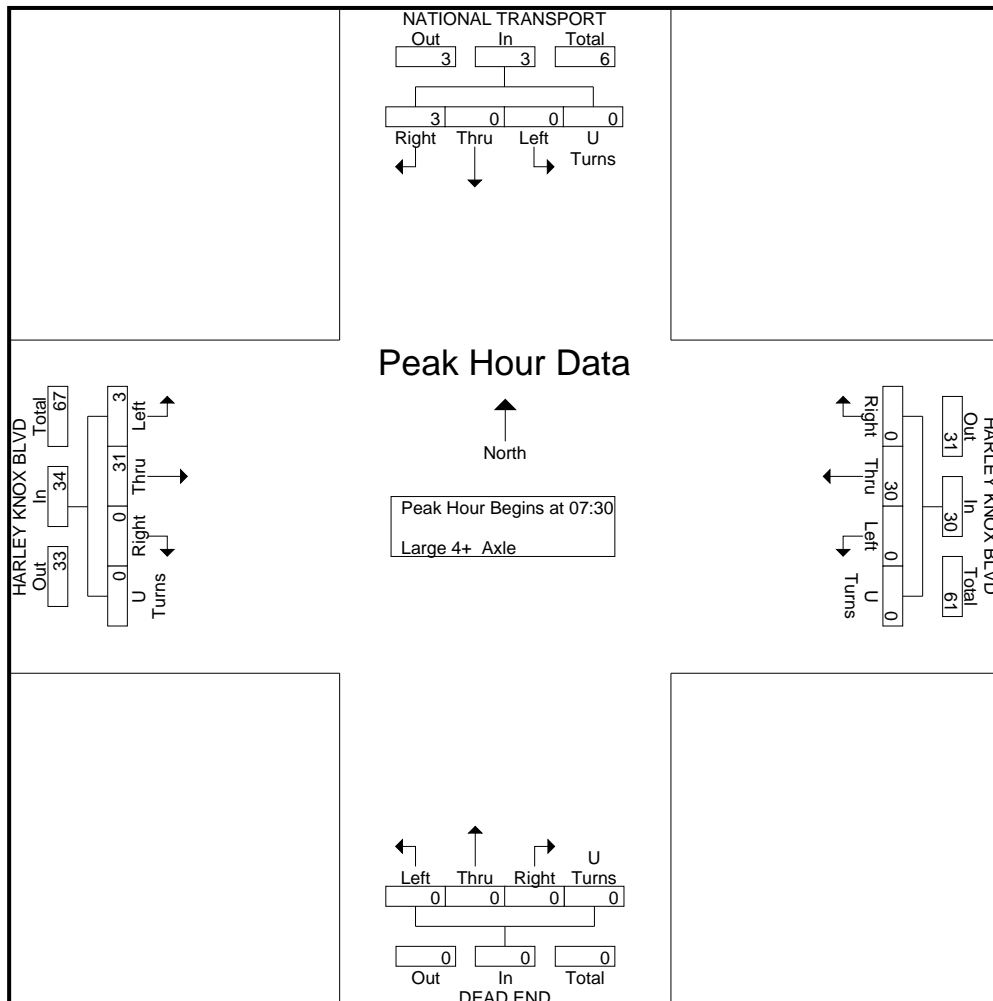

City: PERRIS
 N-S Direction: NATIONAL TRANSPORT
 E-W Direction: HARLEY KNOX BLVD

File Name : H2401002
 Site Code : 0000000
 Start Date : 1/9/2024
 Page No : 3

Start Time	NATIONAL TRANSPORT Southbound					HARLEY KNOX BLVD Westbound					DEAD END Northbound					HARLEY KNOX BLVD Eastbound					Int. Total
	Right	Thru	Left	U Turns	App. Total	Right	Thru	Left	U Turns	App. Total	Right	Thru	Left	U Turns	App. Total	Right	Thru	Left	U Turns	App. Total	
Peak Hour Analysis From 16:00 to 17:45 - Peak 1 of 1																					
Peak Hour for Entire Intersection Begins at 16:00																					
16:00	0	0	0	0	0	0	5	0	0	5	0	0	0	0	0	0	10	0	0	10	15
16:15	0	0	0	0	0	0	8	0	0	8	0	0	0	0	0	0	3	1	0	4	12
16:30	2	0	0	0	2	0	14	0	0	14	0	0	0	0	0	0	7	1	0	8	24
16:45	1	0	0	0	1	0	5	0	0	5	0	0	0	0	0	0	2	1	0	3	9
Total Volume	3	0	0	0	3	0	32	0	0	32	0	0	0	0	0	0	22	3	0	25	60
% App. Total	100	0	0	0		0	100	0	0		0	0	0	0		0	88	12	0		
PHF	.375	.000	.000	.000	.375	.000	.571	.000	.000	.571	.000	.000	.000	.000	.000	.000	.550	.750	.000	.625	.625

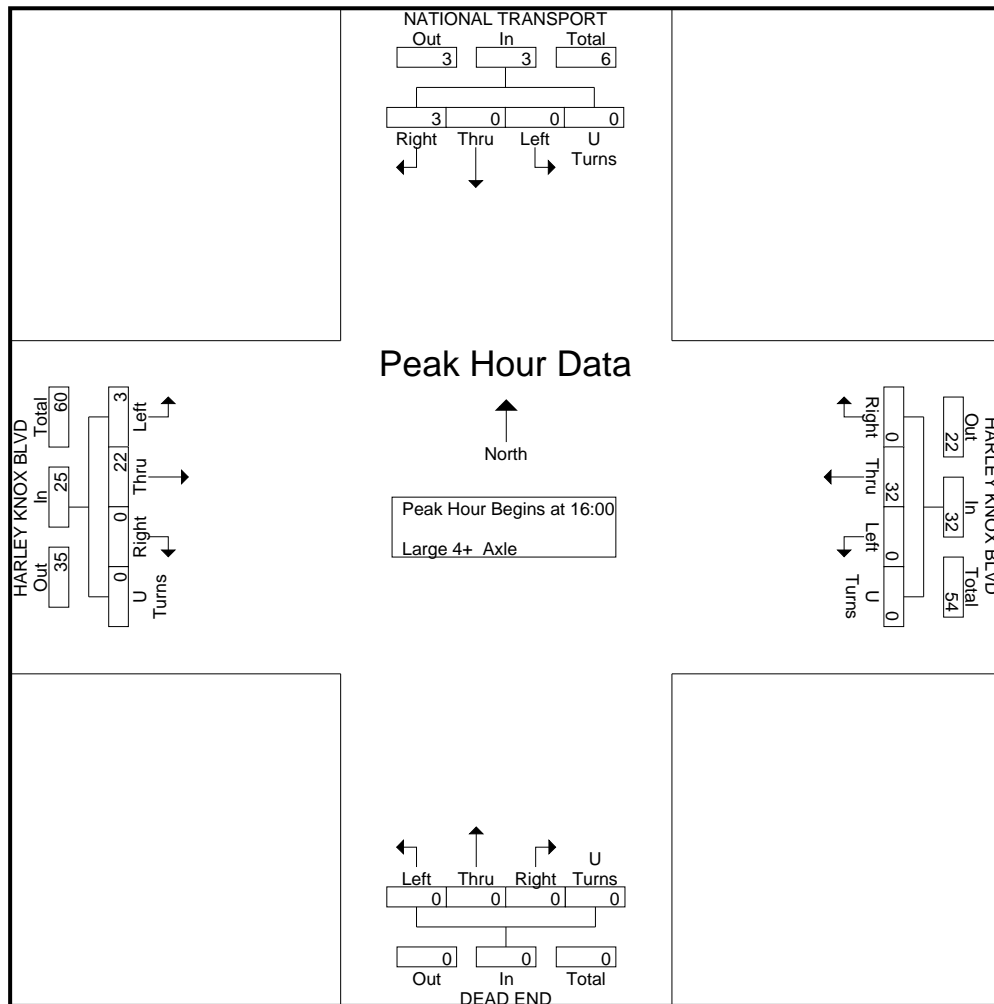

APPENDIX C
CUMULATIVE PROJECT INFORMATION

6.3 Opening Year (2024) Conditions

This section details the Opening Year (2024) traffic volumes and the intersection and roadway operations within the study area. This Opening Year represents a short-term horizon period where the proposed project is constructed and fully occupied. Peak hour traffic forecasts for the Year 2024 have been projected by increasing the traffic volumes by an annual growth rate of 3.0% per year and adding traffic volumes generated by cumulative projects.

6.3.1 Cumulative Projects

Cumulative projects are projects that are proposed and in the review process, but not yet fully approved; or, projects that have been approved, but not fully constructed or occupied. The Opening Year (2024) conditions include the addition of cumulative project traffic to the study area. A list of cumulative project information was provided by the City of Perris and is included in Appendix D, along with cumulative project data for the City of Moreno Valley and County of Riverside. Based on review of the cumulative projects and locations, 63 cumulative projects were identified that would potentially add traffic to the study area. Table 13 provides a brief description of these cumulative projects. Figure 17 illustrates the locations of the cumulative project within the City of Perris, City of Moreno Valley, and the County of Riverside.

Project trip generation estimates for the cumulative projects were taken from traffic studies prepared for the recent development projects and/or derived using ITE *Trip Generation, 11th Edition* (2021) trip rates or from the traffic impact studies or environmental documents available for some of the projects, unless otherwise noted. As shown in Table 13, the cumulative projects are forecast to generate approximately 52,371 daily trips, 3,624 AM peak hour trips, and 4,710 PM peak hour trips. As many of these projects are industrial/warehousing land uses, trip generation estimates were adjusted using PCE factors, resulting in approximately 63,731 daily PCE trips, 4,571 AM peak hour PCE trips, and 5,745 PM peak hour trips.

Table 13. Cumulative Project Trip Generation Summary

ID	Land Use	ITE #	Size/Unit	TSF	Daily	AM Peak Hour			PM Peak Hour			
						In	Out	Total	In	Out	Total	
1	P1	Burge Indus 1	110	18.000	TSF	88	12	2	13	2	10	12
	<i>Burge Indus 1 (PCE)</i>					162	22	3	25	3	19	22
2	P2	Burge Indus 2	110	43.354	TSF	211	28	4	32	4	24	28
	<i>Burge Indus 2 (PCE)</i>					390	52	7	59	7	45	52
3	P3	Duke @ Perry	150	140.000	TSF	246	19	6	24	7	19	26
	<i>Duke @ Perry (PCE)</i>					351	27	8	35	10	27	37
4	P4	IDI @ Ramona	154	426.000	TSF	596	26	8	34	12	31	43
	<i>IDI @ Ramona (PCE)</i>					849	37	11	49	17	44	61
5	P5	Pulliam Indus	110	16.000	TSF	78	10	1	12	1	9	10
	<i>Pulliam Indus (PCE)</i>					144	19	3	22	3	17	19
6	P6	Rider 2 & 4	154	1,373	TSF	1,922	85	25	110	38	99	137
	<i>Rider 2 & 4 (PCE)</i>					2,737	120	36	156	55	141	196
7	P7	Walnut Indu	154	205.000	TSF	287	13	4	16	6	15	21

Table 13. Cumulative Project Trip Generation Summary

ID	Land Use	ITE #	Size/Unit	Daily	AM Peak Hour			PM Peak Hour				
					In	Out	Total	In	Out	Total		
<i>Walnut Indus (PCE)</i>					409	18	5	23	8	21	29	
8	P8	Wilson Indus	154	303.00 0	TSF	424	19	6	24	8	22	30
<i>Wilson Indus (PCE)</i>					604	27	8	35	12	31	43	
9	P9	First Indus (Goodwin)	154	338.00 0	TSF	473	21	6	27	9	24	34
<i>First Indus (Goodwin) (PCE)</i>					674	30	9	39	13	35	48	
10	P10	Canyon Steel (CS)	110	25.000	TSF	122	16	2	19	2	14	16
<i>Canyon Steel (CS) (PCE)</i>					225	30	4	34	4	26	30	
11	P11	Truck Terminal	30	9.5	ac	778	28	41	69	27	35	62
<i>Truck Terminal (PCE)</i>					1,439	52	75	128	49	66	115	
12	P12	Wilson Ind 1	154	248.00 0	TSF	347	15	5	20	7	18	25
<i>Wilson Ind 1 (PCE)</i>					494	22	6	28	10	25	35	
13	P13	Wilson Ind 2	154	155.00 0	TSF	217	10	3	12	4	11	16
<i>Wilson Ind 2 (PCE)</i>					309	14	4	18	6	16	22	
14	P14	Oleander Cultivation	817	12.985	TSF	884	16	16	32	45	45	90
15	P15	Integra - Expansion (IT- E)	154	273.00 0	TSF	382	17	5	22	8	20	27
<i>Integra - Expansion (IT-E) (PCE)</i>					544	24	7	31	11	28	39	
16	P16	Holistic Inc. - Marijuana	140	5.000	TSF	24	3	1	4	2	3	5
17	P17	Marijuana Manufacturin g (MM)	140	1.000	TSF	5	1	1	2	1	1	2
18	P18	Harley Knox 25K	150	12.985	22	2	1	2	1	2	2	22
<i>Harley Knox 25K (PCE)</i>					32	2	1	3	1	2	3	
19	P19	Patriot Ind Perris and Morgan	150	286.89 2	TSF	499	38	12	51	16	40	56
<i>Patriot Ind Perris and Morgan (PCE)</i>					711	55	17	72	23	57	80	
20	P20	Park Ind	150	31.000	TSF	53	4	1	5	2	4	6
<i>Park Ind (PCE)</i>					75	6	2	8	2	6	8	
21	P21	First Harley Knox Ind	154	154.25 0	TSF	264	20	6	26	8	20	28
<i>First Harley Knox Ind (PCE)</i>					376	29	9	37	11	28	40	

Table 13. Cumulative Project Trip Generation Summary

ID	Land Use	ITE #	Size/Unit	Daily	AM Peak Hour			PM Peak Hour				
					In	Out	Total	In	Out	Total		
22	P22	Kwasizur Indu	150	138.00 0	TSF	236	18	5	23	7	18	25
<i>Kwasizur Indu (PCE)</i>					336	26	8	33	10	25	35	
23	P23	Calvio Ind	8	2	10	3	8	11	105	8	2	10
<i>Calvio Ind (PCE)</i>					105	8	2	10	3	8	11	
24	P24	Expressway Industrial	154	347.00 0	TSF	486	21	6	28	10	25	35
<i>Expressway Industrial (PCE)</i>					692	30	9	40	14	36	49	
25	P25	Natwar Ind	154	420.00 0	TSF	588	26	8	34	12	30	42
<i>Natwar Ind (PCE)</i>					837	37	11	48	17	43	60	
26	P26	Serrao Ind	154	3.500	TSF	6	0	0	1	0	0	1
<i>Serrao Ind (PCE)</i>					9	1	0	1	0	1	1	
27	P27	Lakecreek East	154	256.00 0	TSF	438	34	10	44	13	33	46
<i>Lakecreek East (PCE)</i>					623	48	14	62	18	47	66	
28	P28	Lakecreek West	154	300.00 0	TSF	513	39	12	51	15	39	54
<i>Lakecreek West (PCE)</i>					731	56	17	73	22	55	77	
29	P29	Chartwell Ind	154	141.00 0	TSF	241	18	6	24	7	18	25
<i>Chartwell Ind (PCE)</i>					343	26	8	34	10	26	36	
30	P30	SE corner of Perris & Harley Knox	150	345.00 0	TSF	590	45	13	59	17	45	62
<i>SE corner of Perris & Harley Knox (PCE)</i>					840	64	19	84	25	64	88	
31	P31	Duke @ Patterson and Nance	150	580.00 0	TSF	992	76	23	99	29	75	104
<i>Duke @ Patterson and Nance (PCE)</i>					1,412	108	32	140	42	107	149	
32	P32	Nance Ind	150	156.78 0	TSF	272	19	6	25	9	19	28
<i>Nance Ind (PCE)</i>					420	21	8	29	13	22	35	
33	P33	Lakecreek at Harley Knox	154	143.00 0	TSF	245	19	6	24	7	19	26
<i>Lakecreek at Harley Knox (PCE)</i>					348	27	8	35	10	26	37	
34	P34	McKay Indus	150	232.00 0	TSF	397	30	9	39	12	30	42
<i>McKay Indus (PCE)</i>					565	43	13	56	17	43	59	
35	P35	Ramona Gateway Industrial	150	850.00 0	TSF	1,454	111	33	145	43	110	153
<i>Ramona Gateway Industrial (PCE)</i>					2,070	158	47	206	61	157	218	

Table 13. Cumulative Project Trip Generation Summary

ID	Land Use	ITE #	Size/Unit	Daily	AM Peak Hour			PM Peak Hour				
					In	Out	Total	In	Out	Total		
36	P36	Ramona Gateway Commercial	820	35.000	TSF	1,295	18	11	29	57	62	119
37	P37	OLC 3	150	879.000	TSF	1,503	115	34	149	44	114	158
<i>OLC 3 (PCE)</i>					2,140	164	49	213	63	162	225	
38	P38	RG Ind	150	263.000	TSF	450	34	10	45	13	34	47
<i>RG Ind (PCE)</i>					640	49	15	64	19	49	67	
39	P39	Seefried Indus	150	165.000	TSF	282	22	6	28	8	21	30
<i>Seefried Indus (PCE)</i>					402	31	9	40	12	30	42	
40	P40	Brew Indus	150	62.000	TSF	106	8	2	11	3	8	11
<i>Brew Indus (PCE)</i>					151	12	3	15	4	11	16	
41	P41	Dedeaux Markham	150	88.000	TSF	150	12	3	15	4	11	16
<i>Dedeaux Markham (PCE)</i>					214	16	5	21	6	16	23	
42	P42	March Plaza	820	47.253	TSF	1,749	25	15	40	77	84	161
43	P43	Cali Express Carwash	948	5.600	TSF	795	20	20	40	40	40	80
44	P44	Tommy's carwash	948	8.5	TSF	1,207	30	30	60	60	60	121
45	P45	Pacific Ave	210	131	DU	1,235	24	68	92	78	46	123
46	P46	Stratford Ranch	210	270	DU	2,546	49	140	189	160	94	254
47	P47	Barrett Apt	221	228	DU	1,537	22	69	91	73	43	116
48	P48	DR Horton Citrus and Evans	210	161	DU	1,518	29	83	113	95	56	151
49	P49	DR Horton Citrus and Dunlap	210	122	DU	1,150	22	63	85	72	42	115
50	P50	DR Horton Nuevo and Evans	210	75	DU	707	14	39	53	44	26	71
51	P51	Sterling Villa	220	429	DU	2,891	41	130	172	138	81	219
52	P52	Nova Homes	210	76	DU	717	14	39	53	45	26	71
53	P53	Citrus Court	210	111	DU	1,047	20	57	78	66	39	104
54	P54	John Abel Stratford Ranch	210	90	DU	849	16	47	63	53	31	85

Table 13. Cumulative Project Trip Generation Summary

ID	Land Use	ITE #	Size/Unit	Daily	AM Peak Hour			PM Peak Hour				
					In	Out	Total	In	Out	Total		
55	P55	John Abel Stratford Ranch	210	197	DU	1,858	36	102	138	117	69	185
56	P56	May Ranch Multi-Family	211	308	DU	2,076	30	94	123	99	58	157
<i>Subtotal City of Perris</i>					40,409	1,479	1,362	2,841	1,747	1,992	3,740	
<i>Subtotal City of Perris (PCE)</i>					47,496	1,940	1,519	3,460	1,935	2,467	4,402	
57	MV 1	PEN19-0188 PI Properties No. 67 LLC	210	66	DU	622	12	34	46	39	23	62
58	MV 2	PEN18-0042 Ada Deturcios	210	2	DU	19	0	1	1	1	1	2
59	MV 3	PEN21-0021/0215/0216 Perris at Pentecostal	220	426	DU	2,871	41	130	170	137	80	217
60	MV4	PEN21-0179/0180/0188/0189 TTM 38242	220	52	DU	350	5	16	21	17	10	27
<i>Subtotal City of Moreno Valley</i>					3,863	58	181	239	194	114	308	
61	R1	TTM 33978	210	139	DU	1,311	25	72	97	82	48	131
62	R2	Nuevo Distribution Center	154	1,586.645	TSF	2,221	98	29	127	44	114	159
<i>Nuevo Distribution Center (PCE)</i>					3,163	139	42	181	63	163	226	
63	R3	Majestic Freeway Business Center SP	150	816.142	TSF	1,396	107	32	139	41	106	147
			154	2,264.920	TSF	3,171	140	42	181	63	163	226
<i>Majestic Freeway Business Center SP (PCE)</i>					6,503	351	105	456	149	383	532	
<i>Subtotal County of Riverside</i>					8,099	369	175	544	231	431	663	
<i>Subtotal County of Riverside (PCE)</i>					12,372	622	250	872	336	700	1,035	
Total					52,371	1,906	1,717	3,624	2,173	2,538	4,710	
Total (PCE)					63,731	2,621	1,950	4,571	2,464	3,280	5,745	

Notes: TSF = Thousand Square Feet; DU = Dwelling Unit; ac = acres; PCE = Passenger Car Equivalent

Trip distributions and assignments for the cumulative projects were obtained from traffic studies prepared for recent development projects, and/or assuming logical commute corridors. The trips generated by the cumulative projects were distributed through the study area network. Figure 18 shows the cumulative projects traffic volumes for the peak hour conditions. The full cumulative trip generation with calculations is provided in Appendix E.

Figure 19 illustrates the Opening Year (2024) Peak Hour Traffic Volumes.

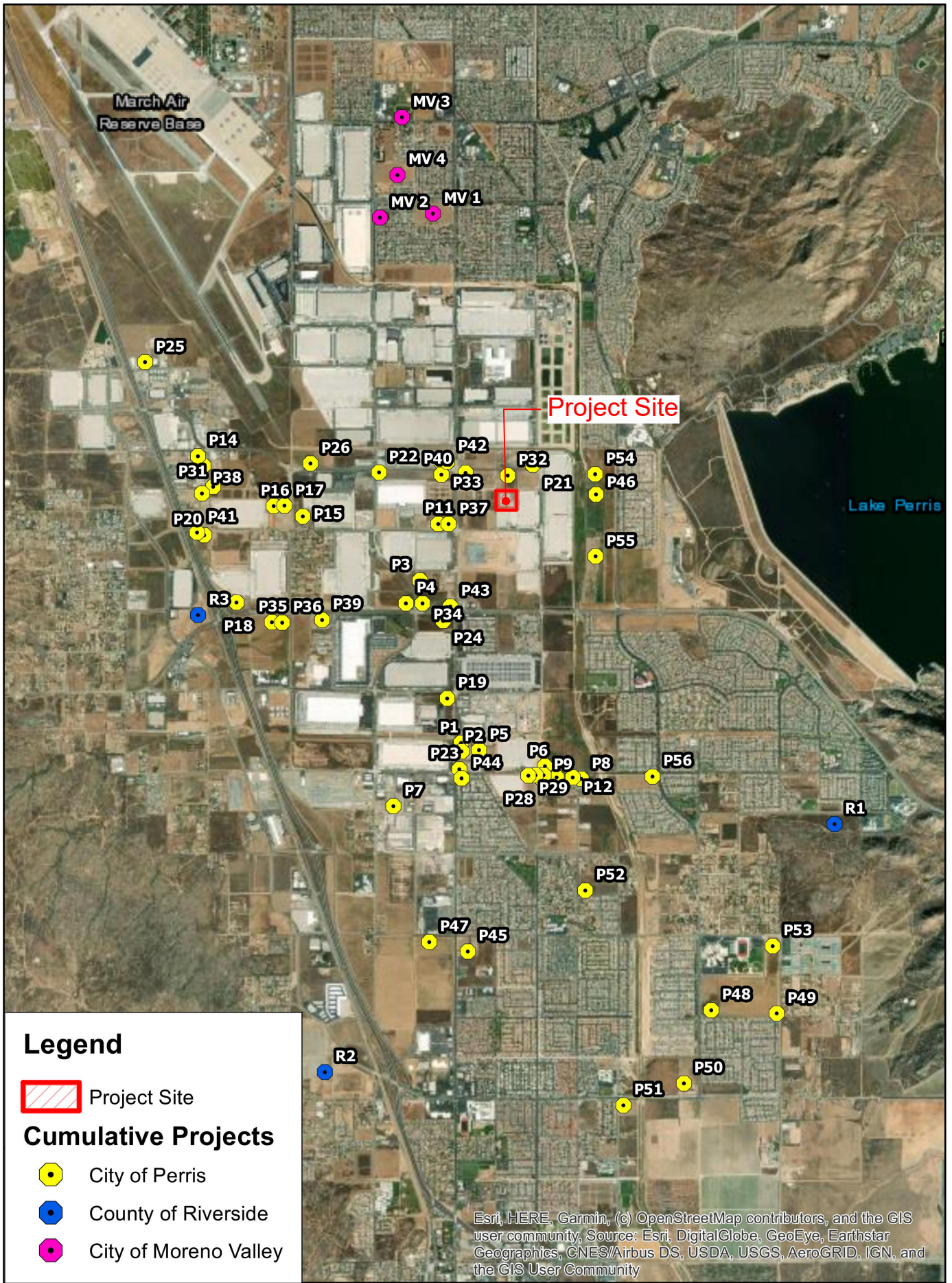

SOURCE: ArcMap; Bing Maps; County of Riverside 2022; City of Moreno Valley 2022; City of Perris 2022

Figure 17

Cumulative Projects Location

255 E. Nance Street Warehouse Project

APPENDIX D

INTERSECTIONS LEVEL OF SERVICE CALCULATION WORKSHEETS

APPENDIX D-1

EXISTING TRAFFIC CONDITIONS

Intersection Level Of Service Report

Intersection 1: Project Driveway No. 1 at Harley Knox Boulevard

Control Type:	Two-way stop	Delay (sec / veh):	12.3
Analysis Method:	HCM 7th Edition	Level Of Service:	B
Analysis Period:	15 minutes	Volume to Capacity (v/c):	0.070

Intersection Setup

Name	Project Driveway No. 1		Harley Knox Boulevard		Harley Knox Boulevard	
Approach	Southbound		Eastbound		Westbound	
Lane Configuration	↻				↻	
Turning Movement	Left	Right	Left	Thru	Thru	Right
Lane Width [ft]	12.00	12.00	12.00	12.00	12.00	12.00
No. of Lanes in Entry Pocket	0	0	0	0	0	1
Entry Pocket Length [ft]	100.00	100.00	100.00	100.00	100.00	100.00
No. of Lanes in Exit Pocket	0	0	0	0	0	0
Exit Pocket Length [ft]	0.00	0.00	0.00	0.00	0.00	0.00
Speed [mph]	25.00		50.00		50.00	
Grade [%]	0.00		0.00		0.00	
Crosswalk	Yes		No		No	

Volumes

Name	Project Driveway No. 1		Harley Knox Boulevard		Harley Knox Boulevard	
Base Volume Input [veh/h]	0	34	0	238	697	26
Base Volume Adjustment Factor	1.0000	1.0000	1.0000	1.0000	1.0000	1.0000
Heavy Vehicles Percentage [%]	2.00	2.00	2.00	2.00	2.00	2.00
Growth Factor	1.0000	1.0000	1.0000	1.0000	1.0000	1.0000
In-Process Volume [veh/h]	0	0	0	0	0	0
Site-Generated Trips [veh/h]	0	0	0	0	0	0
Diverted Trips [veh/h]	0	0	0	0	0	0
Pass-by Trips [veh/h]	0	0	0	0	0	0
Existing Site Adjustment Volume [veh/h]	0	0	0	0	0	0
Other Volume [veh/h]	0	0	0	0	0	0
Total Hourly Volume [veh/h]	0	34	0	238	697	26
Peak Hour Factor	1.0000	0.9310	1.0000	0.9310	0.9310	0.9310
Other Adjustment Factor	1.0000	1.0000	1.0000	1.0000	1.0000	1.0000
Total 15-Minute Volume [veh/h]	0	9	0	64	187	7
Total Analysis Volume [veh/h]	0	37	0	256	749	28
Pedestrian Volume [ped/h]	0		0		0	

Intersection Settings

Priority Scheme	Stop	Free	Free
Flared Lane			
Storage Area [veh]	0	0	0
Two-Stage Gap Acceptance	No		
Number of Storage Spaces in Median	0	0	0

Movement, Approach, & Intersection Results



V/C, Movement V/C Ratio	0.00	0.07	0.00	0.00	0.01	0.00
d_M, Delay for Movement [s/veh]	0.00	12.27	0.00	0.00	0.00	0.00
Movement LOS		B		A	A	A
95th-Percentile Queue Length [veh/ln]	0.00	0.22	0.00	0.00	0.00	0.00
95th-Percentile Queue Length [ft/ln]	0.00	5.58	0.00	0.00	0.00	0.00
d_A, Approach Delay [s/veh]	12.27		0.00		0.00	
Approach LOS	B		A		A	
d_I, Intersection Delay [s/veh]	0.42					
Intersection LOS	B					

Intersection Level Of Service Report

Intersection 2: Project Driveway No. 2 at Harley Knox Boulevard

Control Type:	Two-way stop	Delay (sec / veh):	12.3
Analysis Method:	HCM 7th Edition	Level Of Service:	B
Analysis Period:	15 minutes	Volume to Capacity (v/c):	0.033

Intersection Setup

Name	Project Driveway No. 2		Harley Knox Boulevard		Harley Knox Boulevard	
Approach	Southbound		Eastbound		Westbound	
Lane Configuration						
Turning Movement	Left	Right	Left	Thru	Thru	Right
Lane Width [ft]	12.00	12.00	12.00	12.00	12.00	12.00
No. of Lanes in Entry Pocket	0	0	1	0	0	0
Entry Pocket Length [ft]	100.00	100.00	100.00	100.00	100.00	100.00
No. of Lanes in Exit Pocket	0	0	0	0	0	0
Exit Pocket Length [ft]	0.00	0.00	0.00	0.00	0.00	0.00
Speed [mph]	25.00		50.00		50.00	
Grade [%]	0.00		0.00		0.00	
Crosswalk	Yes		No		No	

Volumes

Name	Project Driveway No. 2		Harley Knox Boulevard		Harley Knox Boulevard	
Base Volume Input [veh/h]	0	9	16	240	711	7
Base Volume Adjustment Factor	1.0000	1.0000	1.0000	1.0000	1.0000	1.0000
Heavy Vehicles Percentage [%]	2.00	2.00	2.00	2.00	2.00	2.00
Growth Factor	1.0000	1.0000	1.0000	1.0000	1.0000	1.0000
In-Process Volume [veh/h]	0	0	0	0	0	0
Site-Generated Trips [veh/h]	0	0	0	0	0	0
Diverted Trips [veh/h]	0	0	0	0	0	0
Pass-by Trips [veh/h]	0	0	0	0	0	0
Existing Site Adjustment Volume [veh/h]	0	0	0	0	0	0
Other Volume [veh/h]	0	0	0	0	0	0
Total Hourly Volume [veh/h]	0	9	16	240	711	7
Peak Hour Factor	1.0000	0.9420	0.9420	0.9420	0.9420	0.9420
Other Adjustment Factor	1.0000	1.0000	1.0000	1.0000	1.0000	1.0000
Total 15-Minute Volume [veh/h]	0	2	4	64	189	2
Total Analysis Volume [veh/h]	0	10	17	255	755	7
Pedestrian Volume [ped/h]	0		0		0	

Intersection Settings

Priority Scheme	Stop	Free	Free
Flared Lane			
Storage Area [veh]	0	0	0
Two-Stage Gap Acceptance	No		
Number of Storage Spaces in Median	0	0	0

Movement, Approach, & Intersection Results

V/C, Movement V/C Ratio	0.00	0.02	0.03	0.00	0.01	0.00
d_M, Delay for Movement [s/veh]	0.00	11.96	12.32	0.00	0.00	0.00
Movement LOS		B	B	A	A	A
95th-Percentile Queue Length [veh/ln]	0.00	0.06	0.10	0.00	0.00	0.00
95th-Percentile Queue Length [ft/ln]	0.00	1.45	2.59	0.00	0.00	0.00
d_A, Approach Delay [s/veh]	11.96		0.77		0.00	
Approach LOS	B		A		A	
d_I, Intersection Delay [s/veh]	0.32					
Intersection LOS	B					

Intersection Level Of Service Report

Intersection 1: Project Driveway No. 1 at Harley Knox Boulevard

Control Type:	Two-way stop	Delay (sec / veh):	11.3
Analysis Method:	HCM 7th Edition	Level Of Service:	B
Analysis Period:	15 minutes	Volume to Capacity (v/c):	0.102

Intersection Setup

Name	Project Driveway No. 1		Harley Knox Boulevard		Harley Knox Boulevard	
Approach	Southbound		Eastbound		Westbound	
Lane Configuration	↻		↑↑↑		↑↑↑↻	
Turning Movement	Left	Right	Left	Thru	Thru	Right
Lane Width [ft]	12.00	12.00	12.00	12.00	12.00	12.00
No. of Lanes in Entry Pocket	0	0	0	0	0	1
Entry Pocket Length [ft]	100.00	100.00	100.00	100.00	100.00	100.00
No. of Lanes in Exit Pocket	0	0	0	0	0	0
Exit Pocket Length [ft]	0.00	0.00	0.00	0.00	0.00	0.00
Speed [mph]	25.00		50.00		50.00	
Grade [%]	0.00		0.00		0.00	
Crosswalk	Yes		No		No	

Volumes

Name	Project Driveway No. 1		Harley Knox Boulevard		Harley Knox Boulevard	
Base Volume Input [veh/h]	0	53	0	465	409	33
Base Volume Adjustment Factor	1.0000	1.0000	1.0000	1.0000	1.0000	1.0000
Heavy Vehicles Percentage [%]	2.00	2.00	2.00	2.00	2.00	2.00
Growth Factor	1.0000	1.0000	1.0000	1.0000	1.0000	1.0000
In-Process Volume [veh/h]	0	0	0	0	0	0
Site-Generated Trips [veh/h]	0	0	0	0	0	0
Diverted Trips [veh/h]	0	0	0	0	0	0
Pass-by Trips [veh/h]	0	0	0	0	0	0
Existing Site Adjustment Volume [veh/h]	0	0	0	0	0	0
Other Volume [veh/h]	0	0	0	0	0	0
Total Hourly Volume [veh/h]	0	53	0	465	409	33
Peak Hour Factor	1.0000	0.8190	1.0000	0.8190	0.8190	0.8190
Other Adjustment Factor	1.0000	1.0000	1.0000	1.0000	1.0000	1.0000
Total 15-Minute Volume [veh/h]	0	16	0	142	125	10
Total Analysis Volume [veh/h]	0	65	0	568	499	40
Pedestrian Volume [ped/h]	0		0		0	

Intersection Settings

Priority Scheme	Stop	Free	Free
Flared Lane			
Storage Area [veh]	0	0	0
Two-Stage Gap Acceptance	No		
Number of Storage Spaces in Median	0	0	0

Movement, Approach, & Intersection Results

V/C, Movement V/C Ratio	0.00	0.10	0.00	0.01	0.00	0.00
d_M, Delay for Movement [s/veh]	0.00	11.27	0.00	0.00	0.00	0.00
Movement LOS		B		A	A	A
95th-Percentile Queue Length [veh/ln]	0.00	0.34	0.00	0.00	0.00	0.00
95th-Percentile Queue Length [ft/ln]	0.00	8.45	0.00	0.00	0.00	0.00
d_A, Approach Delay [s/veh]	11.27		0.00		0.00	
Approach LOS	B		A		A	
d_I, Intersection Delay [s/veh]	0.62					
Intersection LOS	B					

Intersection Level Of Service Report

Intersection 2: Project Driveway No. 2 at Harley Knox Boulevard

Control Type:	Two-way stop	Delay (sec / veh):	11.2
Analysis Method:	HCM 7th Edition	Level Of Service:	B
Analysis Period:	15 minutes	Volume to Capacity (v/c):	0.056

Intersection Setup

Name	Project Driveway No. 2		Harley Knox Boulevard		Harley Knox Boulevard	
Approach	Southbound		Eastbound		Westbound	
Lane Configuration						
Turning Movement	Left	Right	Left	Thru	Thru	Right
Lane Width [ft]	12.00	12.00	12.00	12.00	12.00	12.00
No. of Lanes in Entry Pocket	0	0	1	0	0	0
Entry Pocket Length [ft]	100.00	100.00	100.00	100.00	100.00	100.00
No. of Lanes in Exit Pocket	0	0	0	0	0	0
Exit Pocket Length [ft]	0.00	0.00	0.00	0.00	0.00	0.00
Speed [mph]	25.00		50.00		50.00	
Grade [%]	0.00		0.00		0.00	
Crosswalk	Yes		No		No	

Volumes

Name	Project Driveway No. 2		Harley Knox Boulevard		Harley Knox Boulevard	
Base Volume Input [veh/h]	0	27	30	456	448	1
Base Volume Adjustment Factor	1.0000	1.0000	1.0000	1.0000	1.0000	1.0000
Heavy Vehicles Percentage [%]	2.00	2.00	2.00	2.00	2.00	2.00
Growth Factor	1.0000	1.0000	1.0000	1.0000	1.0000	1.0000
In-Process Volume [veh/h]	0	0	0	0	0	0
Site-Generated Trips [veh/h]	0	0	0	0	0	0
Diverted Trips [veh/h]	0	0	0	0	0	0
Pass-by Trips [veh/h]	0	0	0	0	0	0
Existing Site Adjustment Volume [veh/h]	0	0	0	0	0	0
Other Volume [veh/h]	0	0	0	0	0	0
Total Hourly Volume [veh/h]	0	27	30	456	448	1
Peak Hour Factor	1.0000	0.7980	0.7980	0.7980	0.7980	0.7980
Other Adjustment Factor	1.0000	1.0000	1.0000	1.0000	1.0000	1.0000
Total 15-Minute Volume [veh/h]	0	8	9	143	140	0
Total Analysis Volume [veh/h]	0	34	38	571	561	1
Pedestrian Volume [ped/h]	0		0		0	

Intersection Settings

Priority Scheme	Stop	Free	Free
Flared Lane			
Storage Area [veh]	0	0	0
Two-Stage Gap Acceptance	No		
Number of Storage Spaces in Median	0	0	0

Movement, Approach, & Intersection Results

V/C, Movement V/C Ratio	0.00	0.06	0.06	0.01	0.01	0.00
d_M, Delay for Movement [s/veh]	0.00	11.24	11.05	0.00	0.00	0.00
Movement LOS		B	B	A	A	A
95th-Percentile Queue Length [veh/ln]	0.00	0.18	0.19	0.00	0.00	0.00
95th-Percentile Queue Length [ft/ln]	0.00	4.41	4.78	0.00	0.00	0.00
d_A, Approach Delay [s/veh]	11.24		0.69		0.00	
Approach LOS	B		A		A	
d_I, Intersection Delay [s/veh]	0.67					
Intersection LOS	B					

APPENDIX D-II

**YEAR 2026 CUMULATIVE
TRAFFIC CONDITIONS**

Intersection Level Of Service Report

Intersection 1: Project Driveway No. 1 at Harley Knox Boulevard

Control Type:	Two-way stop	Delay (sec / veh):	12.9
Analysis Method:	HCM 7th Edition	Level Of Service:	B
Analysis Period:	15 minutes	Volume to Capacity (v/c):	0.094

Intersection Setup

Name	Project Driveway No. 1		Harley Knox Boulevard		Harley Knox Boulevard	
Approach	Southbound		Eastbound		Westbound	
Lane Configuration	↻				↻	
Turning Movement	Left	Right	Left	Thru	Thru	Right
Lane Width [ft]	12.00	12.00	12.00	12.00	12.00	12.00
No. of Lanes in Entry Pocket	0	0	0	0	0	1
Entry Pocket Length [ft]	100.00	100.00	100.00	100.00	100.00	100.00
No. of Lanes in Exit Pocket	0	0	0	0	0	0
Exit Pocket Length [ft]	0.00	0.00	0.00	0.00	0.00	0.00
Speed [mph]	25.00		50.00		50.00	
Grade [%]	0.00		0.00		0.00	
Crosswalk	Yes		No		No	

Volumes

Name	Project Driveway No. 1		Harley Knox Boulevard		Harley Knox Boulevard	
Base Volume Input [veh/h]	0	47	0	430	828	60
Base Volume Adjustment Factor	1.0000	1.0000	1.0000	1.0000	1.0000	1.0000
Heavy Vehicles Percentage [%]	2.00	2.00	2.00	2.00	2.00	2.00
Growth Factor	1.0000	1.0000	1.0000	1.0000	1.0000	1.0000
In-Process Volume [veh/h]	0	0	0	0	0	0
Site-Generated Trips [veh/h]	0	0	0	0	0	0
Diverted Trips [veh/h]	0	0	0	0	0	0
Pass-by Trips [veh/h]	0	0	0	0	0	0
Existing Site Adjustment Volume [veh/h]	0	0	0	0	0	0
Other Volume [veh/h]	0	0	0	0	0	0
Total Hourly Volume [veh/h]	0	47	0	430	828	60
Peak Hour Factor	1.0000	1.0000	1.0000	1.0000	1.0000	1.0000
Other Adjustment Factor	1.0000	1.0000	1.0000	1.0000	1.0000	1.0000
Total 15-Minute Volume [veh/h]	0	12	0	108	207	15
Total Analysis Volume [veh/h]	0	47	0	430	828	60
Pedestrian Volume [ped/h]	0		0		0	

Intersection Settings

Priority Scheme	Stop	Free	Free
Flared Lane			
Storage Area [veh]	0	0	0
Two-Stage Gap Acceptance	No		
Number of Storage Spaces in Median	0	0	0

Movement, Approach, & Intersection Results

V/C, Movement V/C Ratio	0.00	0.09	0.00	0.00	0.01	0.00
d_M, Delay for Movement [s/veh]	0.00	12.91	0.00	0.00	0.00	0.00
Movement LOS		B		A	A	A
95th-Percentile Queue Length [veh/ln]	0.00	0.31	0.00	0.00	0.00	0.00
95th-Percentile Queue Length [ft/ln]	0.00	7.71	0.00	0.00	0.00	0.00
d_A, Approach Delay [s/veh]	12.91		0.00		0.00	
Approach LOS	B		A		A	
d_I, Intersection Delay [s/veh]	0.44					
Intersection LOS	B					

Intersection Level Of Service Report

Intersection 2: Project Driveway No. 2 at Harley Knox Boulevard

Control Type:	Two-way stop	Delay (sec / veh):	13.3
Analysis Method:	HCM 7th Edition	Level Of Service:	B
Analysis Period:	15 minutes	Volume to Capacity (v/c):	0.048

Intersection Setup

Name	Project Driveway No. 2		Harley Knox Boulevard		Harley Knox Boulevard	
Approach	Southbound		Eastbound		Westbound	
Lane Configuration						
Turning Movement	Left	Right	Left	Thru	Thru	Right
Lane Width [ft]	12.00	12.00	12.00	12.00	12.00	12.00
No. of Lanes in Entry Pocket	0	0	1	0	0	0
Entry Pocket Length [ft]	100.00	100.00	100.00	100.00	100.00	100.00
No. of Lanes in Exit Pocket	0	0	0	0	0	0
Exit Pocket Length [ft]	0.00	0.00	0.00	0.00	0.00	0.00
Speed [mph]	25.00		50.00		50.00	
Grade [%]	0.00		0.00		0.00	
Crosswalk	Yes		No		No	

Volumes

Name	Project Driveway No. 2		Harley Knox Boulevard		Harley Knox Boulevard	
Base Volume Input [veh/h]	0	15	22	432	854	7
Base Volume Adjustment Factor	1.0000	1.0000	1.0000	1.0000	1.0000	1.0000
Heavy Vehicles Percentage [%]	2.00	2.00	2.00	2.00	2.00	2.00
Growth Factor	1.0000	1.0000	1.0000	1.0000	1.0000	1.0000
In-Process Volume [veh/h]	0	0	0	0	0	0
Site-Generated Trips [veh/h]	0	0	0	0	0	0
Diverted Trips [veh/h]	0	0	0	0	0	0
Pass-by Trips [veh/h]	0	0	0	0	0	0
Existing Site Adjustment Volume [veh/h]	0	0	0	0	0	0
Other Volume [veh/h]	0	0	0	0	0	0
Total Hourly Volume [veh/h]	0	15	22	432	854	7
Peak Hour Factor	1.0000	1.0000	1.0000	1.0000	1.0000	1.0000
Other Adjustment Factor	1.0000	1.0000	1.0000	1.0000	1.0000	1.0000
Total 15-Minute Volume [veh/h]	0	4	6	108	214	2
Total Analysis Volume [veh/h]	0	15	22	432	854	7
Pedestrian Volume [ped/h]	0		0		0	

Intersection Settings

Priority Scheme	Stop	Free	Free
Flared Lane			
Storage Area [veh]	0	0	0
Two-Stage Gap Acceptance	No		
Number of Storage Spaces in Median	0	0	0

Movement, Approach, & Intersection Results

V/C, Movement V/C Ratio	0.00	0.03	0.05	0.00	0.01	0.00
d_M, Delay for Movement [s/veh]	0.00	12.58	13.28	0.00	0.00	0.00
Movement LOS		B	B	A	A	A
95th-Percentile Queue Length [veh/ln]	0.00	0.09	0.15	0.00	0.00	0.00
95th-Percentile Queue Length [ft/ln]	0.00	2.37	3.79	0.00	0.00	0.00
d_A, Approach Delay [s/veh]	12.58		0.64		0.00	
Approach LOS	B		A		A	
d_I, Intersection Delay [s/veh]	0.36					
Intersection LOS	B					

Intersection Level Of Service Report

Intersection 1: Project Driveway No. 1 at Harley Knox Boulevard

Control Type:	Two-way stop	Delay (sec / veh):	11.9
Analysis Method:	HCM 7th Edition	Level Of Service:	B
Analysis Period:	15 minutes	Volume to Capacity (v/c):	0.108

Intersection Setup

Name	Project Driveway No. 1		Harley Knox Boulevard		Harley Knox Boulevard	
Approach	Southbound		Eastbound		Westbound	
Lane Configuration	↻				↻	
Turning Movement	Left	Right	Left	Thru	Thru	Right
Lane Width [ft]	12.00	12.00	12.00	12.00	12.00	12.00
No. of Lanes in Entry Pocket	0	0	0	0	0	1
Entry Pocket Length [ft]	100.00	100.00	100.00	100.00	100.00	100.00
No. of Lanes in Exit Pocket	0	0	0	0	0	0
Exit Pocket Length [ft]	0.00	0.00	0.00	0.00	0.00	0.00
Speed [mph]	25.00		50.00		50.00	
Grade [%]	0.00		0.00		0.00	
Crosswalk	Yes		No		No	

Volumes

Name	Project Driveway No. 1		Harley Knox Boulevard		Harley Knox Boulevard	
Base Volume Input [veh/h]	0	63	0	615	629	58
Base Volume Adjustment Factor	1.0000	1.0000	1.0000	1.0000	1.0000	1.0000
Heavy Vehicles Percentage [%]	2.00	2.00	2.00	2.00	2.00	2.00
Growth Factor	1.0000	1.0000	1.0000	1.0000	1.0000	1.0000
In-Process Volume [veh/h]	0	0	0	0	0	0
Site-Generated Trips [veh/h]	0	0	0	0	0	0
Diverted Trips [veh/h]	0	0	0	0	0	0
Pass-by Trips [veh/h]	0	0	0	0	0	0
Existing Site Adjustment Volume [veh/h]	0	0	0	0	0	0
Other Volume [veh/h]	0	0	0	0	0	0
Total Hourly Volume [veh/h]	0	63	0	615	629	58
Peak Hour Factor	1.0000	1.0000	1.0000	1.0000	1.0000	1.0000
Other Adjustment Factor	1.0000	1.0000	1.0000	1.0000	1.0000	1.0000
Total 15-Minute Volume [veh/h]	0	16	0	154	157	15
Total Analysis Volume [veh/h]	0	63	0	615	629	58
Pedestrian Volume [ped/h]	0		0		0	

Intersection Settings

Priority Scheme	Stop	Free	Free
Flared Lane			
Storage Area [veh]	0	0	0
Two-Stage Gap Acceptance	No		
Number of Storage Spaces in Median	0	0	0

Movement, Approach, & Intersection Results

V/C, Movement V/C Ratio	0.00	0.11	0.00	0.01	0.01	0.00
d_M, Delay for Movement [s/veh]	0.00	11.95	0.00	0.00	0.00	0.00
Movement LOS		B		A	A	A
95th-Percentile Queue Length [veh/ln]	0.00	0.36	0.00	0.00	0.00	0.00
95th-Percentile Queue Length [ft/ln]	0.00	9.07	0.00	0.00	0.00	0.00
d_A, Approach Delay [s/veh]	11.95		0.00		0.00	
Approach LOS	B		A		A	
d_I, Intersection Delay [s/veh]	0.55					
Intersection LOS	B					

Intersection Level Of Service Report

Intersection 2: Project Driveway No. 2 at Harley Knox Boulevard

Control Type:	Two-way stop	Delay (sec / veh):	11.9
Analysis Method:	HCM 7th Edition	Level Of Service:	B
Analysis Period:	15 minutes	Volume to Capacity (v/c):	0.064

Intersection Setup

Name	Project Driveway No. 2		Harley Knox Boulevard		Harley Knox Boulevard	
Approach	Southbound		Eastbound		Westbound	
Lane Configuration						
Turning Movement	Left	Right	Left	Thru	Thru	Right
Lane Width [ft]	12.00	12.00	12.00	12.00	12.00	12.00
No. of Lanes in Entry Pocket	0	0	1	0	0	0
Entry Pocket Length [ft]	100.00	100.00	100.00	100.00	100.00	100.00
No. of Lanes in Exit Pocket	0	0	0	0	0	0
Exit Pocket Length [ft]	0.00	0.00	0.00	0.00	0.00	0.00
Speed [mph]	25.00		50.00		50.00	
Grade [%]	0.00		0.00		0.00	
Crosswalk	Yes		No		No	

Volumes

Name	Project Driveway No. 2		Harley Knox Boulevard		Harley Knox Boulevard	
Base Volume Input [veh/h]	0	32	36	605	677	1
Base Volume Adjustment Factor	1.0000	1.0000	1.0000	1.0000	1.0000	1.0000
Heavy Vehicles Percentage [%]	2.00	2.00	2.00	2.00	2.00	2.00
Growth Factor	1.0000	1.0000	1.0000	1.0000	1.0000	1.0000
In-Process Volume [veh/h]	0	0	0	0	0	0
Site-Generated Trips [veh/h]	0	0	0	0	0	0
Diverted Trips [veh/h]	0	0	0	0	0	0
Pass-by Trips [veh/h]	0	0	0	0	0	0
Existing Site Adjustment Volume [veh/h]	0	0	0	0	0	0
Other Volume [veh/h]	0	0	0	0	0	0
Total Hourly Volume [veh/h]	0	32	36	605	677	1
Peak Hour Factor	1.0000	1.0000	1.0000	1.0000	1.0000	1.0000
Other Adjustment Factor	1.0000	1.0000	1.0000	1.0000	1.0000	1.0000
Total 15-Minute Volume [veh/h]	0	8	9	151	169	0
Total Analysis Volume [veh/h]	0	32	36	605	677	1
Pedestrian Volume [ped/h]	0		0		0	

Intersection Settings

Priority Scheme	Stop	Free	Free
Flared Lane			
Storage Area [veh]	0	0	0
Two-Stage Gap Acceptance	No		
Number of Storage Spaces in Median	0	0	0

Movement, Approach, & Intersection Results

V/C, Movement V/C Ratio	0.00	0.06	0.06	0.01	0.01	0.00
d_M, Delay for Movement [s/veh]	0.00	11.81	11.89	0.00	0.00	0.00
Movement LOS		B	B	A	A	A
95th-Percentile Queue Length [veh/ln]	0.00	0.18	0.21	0.00	0.00	0.00
95th-Percentile Queue Length [ft/ln]	0.00	4.53	5.15	0.00	0.00	0.00
d_A, Approach Delay [s/veh]	11.81		0.67		0.00	
Approach LOS	B		A		A	
d_I, Intersection Delay [s/veh]	0.60					
Intersection LOS	B					

APPENDIX D-III

**YEAR 2026 CUMULATIVE PLUS PROJECT
TRAFFIC CONDITIONS**

Intersection Level Of Service Report

Intersection 1: Project Driveway No. 1 at Harley Knox Boulevard

Control Type:	Two-way stop	Delay (sec / veh):	13.0
Analysis Method:	HCM 7th Edition	Level Of Service:	B
Analysis Period:	15 minutes	Volume to Capacity (v/c):	0.098

Intersection Setup

Name	Project Driveway No. 1		Harley Knox Boulevard		Harley Knox Boulevard	
Approach	Southbound		Eastbound		Westbound	
Lane Configuration	↻				↻	
Turning Movement	Left	Right	Left	Thru	Thru	Right
Lane Width [ft]	12.00	12.00	12.00	12.00	12.00	12.00
No. of Lanes in Entry Pocket	0	0	0	0	0	1
Entry Pocket Length [ft]	100.00	100.00	100.00	100.00	100.00	100.00
No. of Lanes in Exit Pocket	0	0	0	0	0	0
Exit Pocket Length [ft]	0.00	0.00	0.00	0.00	0.00	0.00
Speed [mph]	25.00		50.00		50.00	
Grade [%]	0.00		0.00		0.00	
Crosswalk	Yes		No		No	

Volumes

Name	Project Driveway No. 1		Harley Knox Boulevard		Harley Knox Boulevard	
Base Volume Input [veh/h]	0	49	0	430	829	63
Base Volume Adjustment Factor	1.0000	1.0000	1.0000	1.0000	1.0000	1.0000
Heavy Vehicles Percentage [%]	2.00	2.00	2.00	2.00	2.00	2.00
Growth Factor	1.0000	1.0000	1.0000	1.0000	1.0000	1.0000
In-Process Volume [veh/h]	0	0	0	0	0	0
Site-Generated Trips [veh/h]	0	0	0	0	0	0
Diverted Trips [veh/h]	0	0	0	0	0	0
Pass-by Trips [veh/h]	0	0	0	0	0	0
Existing Site Adjustment Volume [veh/h]	0	0	0	0	0	0
Other Volume [veh/h]	0	0	0	0	0	0
Total Hourly Volume [veh/h]	0	49	0	430	829	63
Peak Hour Factor	1.0000	1.0000	1.0000	1.0000	1.0000	1.0000
Other Adjustment Factor	1.0000	1.0000	1.0000	1.0000	1.0000	1.0000
Total 15-Minute Volume [veh/h]	0	12	0	108	207	16
Total Analysis Volume [veh/h]	0	49	0	430	829	63
Pedestrian Volume [ped/h]	0		0		0	

Intersection Settings

Priority Scheme	Stop	Free	Free
Flared Lane			
Storage Area [veh]	0	0	0
Two-Stage Gap Acceptance	No		
Number of Storage Spaces in Median	0	0	0

Movement, Approach, & Intersection Results



V/C, Movement V/C Ratio	0.00	0.10	0.00	0.00	0.01	0.00
d_M, Delay for Movement [s/veh]	0.00	12.95	0.00	0.00	0.00	0.00
Movement LOS		B		A	A	A
95th-Percentile Queue Length [veh/ln]	0.00	0.32	0.00	0.00	0.00	0.00
95th-Percentile Queue Length [ft/ln]	0.00	8.07	0.00	0.00	0.00	0.00
d_A, Approach Delay [s/veh]	12.95		0.00		0.00	
Approach LOS	B		A		A	
d_I, Intersection Delay [s/veh]	0.46					
Intersection LOS	B					

Intersection Level Of Service Report

Intersection 2: Project Driveway No. 2 at Harley Knox Boulevard

Control Type:	Two-way stop	Delay (sec / veh):	13.6
Analysis Method:	HCM 7th Edition	Level Of Service:	B
Analysis Period:	15 minutes	Volume to Capacity (v/c):	0.077

Intersection Setup

Name	Project Driveway No. 2		Harley Knox Boulevard		Harley Knox Boulevard	
Approach	Southbound		Eastbound		Westbound	
Lane Configuration						
Turning Movement	Left	Right	Left	Thru	Thru	Right
Lane Width [ft]	12.00	12.00	12.00	12.00	12.00	12.00
No. of Lanes in Entry Pocket	0	0	1	0	0	0
Entry Pocket Length [ft]	100.00	100.00	100.00	100.00	100.00	100.00
No. of Lanes in Exit Pocket	0	0	0	0	0	0
Exit Pocket Length [ft]	0.00	0.00	0.00	0.00	0.00	0.00
Speed [mph]	25.00		50.00		50.00	
Grade [%]	0.00		0.00		0.00	
Crosswalk	Yes		No		No	

Volumes

Name	Project Driveway No. 2		Harley Knox Boulevard		Harley Knox Boulevard	
Base Volume Input [veh/h]	0	17	35	432	856	8
Base Volume Adjustment Factor	1.0000	1.0000	1.0000	1.0000	1.0000	1.0000
Heavy Vehicles Percentage [%]	2.00	2.00	2.00	2.00	2.00	2.00
Growth Factor	1.0000	1.0000	1.0000	1.0000	1.0000	1.0000
In-Process Volume [veh/h]	0	0	0	0	0	0
Site-Generated Trips [veh/h]	0	0	0	0	0	0
Diverted Trips [veh/h]	0	0	0	0	0	0
Pass-by Trips [veh/h]	0	0	0	0	0	0
Existing Site Adjustment Volume [veh/h]	0	0	0	0	0	0
Other Volume [veh/h]	0	0	0	0	0	0
Total Hourly Volume [veh/h]	0	17	35	432	856	8
Peak Hour Factor	1.0000	1.0000	1.0000	1.0000	1.0000	1.0000
Other Adjustment Factor	1.0000	1.0000	1.0000	1.0000	1.0000	1.0000
Total 15-Minute Volume [veh/h]	0	4	9	108	214	2
Total Analysis Volume [veh/h]	0	17	35	432	856	8
Pedestrian Volume [ped/h]	0		0		0	

Intersection Settings

Priority Scheme	Stop	Free	Free
Flared Lane			
Storage Area [veh]	0	0	0
Two-Stage Gap Acceptance	No		
Number of Storage Spaces in Median	0	0	0

Movement, Approach, & Intersection Results

V/C, Movement V/C Ratio	0.00	0.03	0.08	0.00	0.01	0.00
d_M, Delay for Movement [s/veh]	0.00	12.63	13.57	0.00	0.00	0.00
Movement LOS		B	B	A	A	A
95th-Percentile Queue Length [veh/ln]	0.00	0.11	0.25	0.00	0.00	0.00
95th-Percentile Queue Length [ft/ln]	0.00	2.70	6.22	0.00	0.00	0.00
d_A, Approach Delay [s/veh]	12.63		1.02		0.00	
Approach LOS	B		A		A	
d_I, Intersection Delay [s/veh]	0.51					
Intersection LOS	B					

Intersection Level Of Service Report

Intersection 1: Project Driveway No. 1 at Harley Knox Boulevard

Control Type:	Two-way stop	Delay (sec / veh):	12.0
Analysis Method:	HCM 7th Edition	Level Of Service:	B
Analysis Period:	15 minutes	Volume to Capacity (v/c):	0.119

Intersection Setup

Name	Project Driveway No. 1		Harley Knox Boulevard		Harley Knox Boulevard	
Approach	Southbound		Eastbound		Westbound	
Lane Configuration	↻				↻	
Turning Movement	Left	Right	Left	Thru	Thru	Right
Lane Width [ft]	12.00	12.00	12.00	12.00	12.00	12.00
No. of Lanes in Entry Pocket	0	0	0	0	0	1
Entry Pocket Length [ft]	100.00	100.00	100.00	100.00	100.00	100.00
No. of Lanes in Exit Pocket	0	0	0	0	0	0
Exit Pocket Length [ft]	0.00	0.00	0.00	0.00	0.00	0.00
Speed [mph]	25.00		50.00		50.00	
Grade [%]	0.00		0.00		0.00	
Crosswalk	Yes		No		No	

Volumes

Name	Project Driveway No. 1		Harley Knox Boulevard		Harley Knox Boulevard	
Base Volume Input [veh/h]	0	69	0	615	629	59
Base Volume Adjustment Factor	1.0000	1.0000	1.0000	1.0000	1.0000	1.0000
Heavy Vehicles Percentage [%]	2.00	2.00	2.00	2.00	2.00	2.00
Growth Factor	1.0000	1.0000	1.0000	1.0000	1.0000	1.0000
In-Process Volume [veh/h]	0	0	0	0	0	0
Site-Generated Trips [veh/h]	0	0	0	0	0	0
Diverted Trips [veh/h]	0	0	0	0	0	0
Pass-by Trips [veh/h]	0	0	0	0	0	0
Existing Site Adjustment Volume [veh/h]	0	0	0	0	0	0
Other Volume [veh/h]	0	0	0	0	0	0
Total Hourly Volume [veh/h]	0	69	0	615	629	59
Peak Hour Factor	1.0000	1.0000	1.0000	1.0000	1.0000	1.0000
Other Adjustment Factor	1.0000	1.0000	1.0000	1.0000	1.0000	1.0000
Total 15-Minute Volume [veh/h]	0	17	0	154	157	15
Total Analysis Volume [veh/h]	0	69	0	615	629	59
Pedestrian Volume [ped/h]	0		0		0	

Intersection Settings

Priority Scheme	Stop	Free	Free
Flared Lane			
Storage Area [veh]	0	0	0
Two-Stage Gap Acceptance	No		
Number of Storage Spaces in Median	0	0	0

Movement, Approach, & Intersection Results

V/C, Movement V/C Ratio	0.00	0.12	0.00	0.01	0.01	0.00
d_M, Delay for Movement [s/veh]	0.00	12.03	0.00	0.00	0.00	0.00
Movement LOS		B		A	A	A
95th-Percentile Queue Length [veh/ln]	0.00	0.40	0.00	0.00	0.00	0.00
95th-Percentile Queue Length [ft/ln]	0.00	10.04	0.00	0.00	0.00	0.00
d_A, Approach Delay [s/veh]	12.03		0.00		0.00	
Approach LOS	B		A		A	
d_I, Intersection Delay [s/veh]	0.60					
Intersection LOS	B					

Intersection Level Of Service Report

Intersection 2: Project Driveway No. 2 at Harley Knox Boulevard

Control Type:	Two-way stop	Delay (sec / veh):	12.0
Analysis Method:	HCM 7th Edition	Level Of Service:	B
Analysis Period:	15 minutes	Volume to Capacity (v/c):	0.072

Intersection Setup

Name	Project Driveway No. 2		Harley Knox Boulevard		Harley Knox Boulevard	
Approach	Southbound		Eastbound		Westbound	
Lane Configuration						
Turning Movement	Left	Right	Left	Thru	Thru	Right
Lane Width [ft]	12.00	12.00	12.00	12.00	12.00	12.00
No. of Lanes in Entry Pocket	0	0	1	0	0	0
Entry Pocket Length [ft]	100.00	100.00	100.00	100.00	100.00	100.00
No. of Lanes in Exit Pocket	0	0	0	0	0	0
Exit Pocket Length [ft]	0.00	0.00	0.00	0.00	0.00	0.00
Speed [mph]	25.00		50.00		50.00	
Grade [%]	0.00		0.00		0.00	
Crosswalk	Yes		No		No	

Volumes

Name	Project Driveway No. 2		Harley Knox Boulevard		Harley Knox Boulevard	
Base Volume Input [veh/h]	0	38	40	605	683	1
Base Volume Adjustment Factor	1.0000	1.0000	1.0000	1.0000	1.0000	1.0000
Heavy Vehicles Percentage [%]	2.00	2.00	2.00	2.00	2.00	2.00
Growth Factor	1.0000	1.0000	1.0000	1.0000	1.0000	1.0000
In-Process Volume [veh/h]	0	0	0	0	0	0
Site-Generated Trips [veh/h]	0	0	0	0	0	0
Diverted Trips [veh/h]	0	0	0	0	0	0
Pass-by Trips [veh/h]	0	0	0	0	0	0
Existing Site Adjustment Volume [veh/h]	0	0	0	0	0	0
Other Volume [veh/h]	0	0	0	0	0	0
Total Hourly Volume [veh/h]	0	38	40	605	683	1
Peak Hour Factor	1.0000	1.0000	1.0000	1.0000	1.0000	1.0000
Other Adjustment Factor	1.0000	1.0000	1.0000	1.0000	1.0000	1.0000
Total 15-Minute Volume [veh/h]	0	10	10	151	171	0
Total Analysis Volume [veh/h]	0	38	40	605	683	1
Pedestrian Volume [ped/h]	0		0		0	

Intersection Settings

Priority Scheme	Stop	Free	Free
Flared Lane			
Storage Area [veh]	0	0	0
Two-Stage Gap Acceptance	No		
Number of Storage Spaces in Median	0	0	0

Movement, Approach, & Intersection Results

V/C, Movement V/C Ratio	0.00	0.07	0.07	0.01	0.01	0.00
d_M, Delay for Movement [s/veh]	0.00	11.92	12.00	0.00	0.00	0.00
Movement LOS		B	B	A	A	A
95th-Percentile Queue Length [veh/ln]	0.00	0.22	0.23	0.00	0.00	0.00
95th-Percentile Queue Length [ft/ln]	0.00	5.46	5.81	0.00	0.00	0.00
d_A, Approach Delay [s/veh]	11.92		0.74		0.00	
Approach LOS	B		A		A	
d_I, Intersection Delay [s/veh]	0.68					
Intersection LOS	B					

APPENDIX E
VMT SCOPING FORM



**CITY OF PERRIS
VMT SCOPING FORM FOR LAND USE PROJECTS**

This Scoping Form acknowledges the City of Perris requirements for the evaluation of transportation impacts under CEQA. The analysis provided in this form should follow the City of Perris TIA Guidelines, dated May 12, 2020.

I. Project Description

Tract/Case No.

Project Name:

Project Location:

Project Description:

(Please attach a copy of the project Site Plan)

Current GP Land Use:

Proposed GP Land Use:

Current Zoning:

Proposed Zoning:

If a project requires a General Plan Amendment or Zone change, then additional information and analysis should be provided to ensure the project is consistent with RHNA and RTP/SCS Strategies.

II. VMT Screening Criteria

- A. Is the Project 100% affordable housing?

YES		NO	X
-----	--	----	---

 Attachments:
- B. Is the Project within 1/2 mile of qualifying transit?

YES	X	NO	
-----	---	----	--

 Attachments:
- C. Is the Project a local serving land use?

YES		NO	X
-----	--	----	---

 Attachments:
- D. Is the Project in a low VMT area?

YES		NO	X
-----	--	----	---

 Attachments:
- E. Are the Project's Net Daily Trips less than 500 ADT?

YES	X	NO	
-----	---	----	--

 Attachments:

Low VMT Area Evaluation:

Citywide VMT Averages ¹		
Citywide Home-Based VMT =	15.05	VMT/Capita
Citywide Employment-Based VMT =	11.62	VMT/Employee

[WRCOG VMT MAP](#)

Project TAZ	VMT Rate for Project TAZ ¹		Type of Project	
3754	13.42	VMT/Capita	Residential:	
	12.19	VMT/Employee	Non-Residential:	X

¹ Base year (2012) projections from RIVTAM.

Trip Generation Evaluation:

Source of Trip Generation:

Project Trip Generation:

284	Average Daily Trips (ADT)
-----	---------------------------

Internal Trip Credit:	YES	<input type="text"/>	NO	<input checked="" type="checkbox"/>	% Trip Credit:	<input type="text"/>
Pass-By Trip Credit:	YES	<input type="text"/>	NO	<input checked="" type="checkbox"/>	% Trip Credit:	<input type="text"/>
Affordable Housing Credit:	YES	<input type="text"/>	NO	<input checked="" type="checkbox"/>	% Trip Credit:	<input type="text"/>
Existing Land Use Trip Credit:	YES	<input type="text"/>	NO	<input checked="" type="checkbox"/>	Trip Credit:	<input type="text"/>

Net Project Daily Trips:

284	Average Daily Trips (ADT)
-----	---------------------------

 Attachments:

Does project trip generation warrant an LOS evaluation outside of CEQA?

YES		NO	X
-----	--	----	---

III. VMT Screening Summary

A. Is the Project presumed to have a less than significant impact on VMT?

A Project is presumed to have a less than significant impact on VMT if the Project satisfies at least one (1) of the VMT screening criteria.

Less Than Significant

B. Is mitigation required?

If the Project does not satisfy at least one (1) of the VMT screening criteria, then mitigation is required to reduce the Project's impact on VMT.

No Mitigation Required

C. Is additional VMT modeling required to evaluate Project impacts?

YES		NO	X
-----	--	----	---

If the Project requires a zone change and/or General Plan Amendment AND generates 2,500 or more net daily trips, then additional VMT modeling using RIVTAM/RIVCOM is required. If the project generates less than 2,500 net daily trips, the Project TAZ VMT Rate can be used for mitigation purposes.

IV. MITIGATION

A. Citywide Average VMT Rate (Threshold of Significance) for Mitigation Purposes:

N/A	N/A
-----	-----

B. Unmitigated Project TAZ VMT Rate:

N/A	N/A
-----	-----

C. Percentage Reduction Required to Achieve the Citywide Average VMT:

N/A

D. VMT Reduction Mitigation Measures:

Source of VMT Reduction Estimates:	N/A
---	-----

Project Location Setting	
---------------------------------	--

	VMT Reduction Mitigation Measure:	Estimated VMT Reduction (%)
1.		0.00%
2.		0.00%
3.		0.00%
4.		0.00%
5.		0.00%
6.		0.00%
7.		0.00%
8.		0.00%
9.		0.00%
10.		0.00%
Total VMT Reduction (%)		0.00%

(Attach additional pages, if necessary, and a copy of all mitigation calculations.)

E. Mitigated Project TAZ VMT Rate:

N/A	N/A
-----	-----

F. Is the project presumed to have a less than significant impact with mitigation?

N/A

If the mitigated Project VMT rate is below the Citywide Average Rate, then the Project is presumed to have a less than significant impact with mitigation. If the answer is no, then additional VMT modeling may be required and a potentially significant and unavoidable impact may occur. All mitigation measures identified in Section IV.D. are subject to become Conditions of Approval of the project. Development review and processing fees should be submitted with, or prior to the submittal of this Form. The Planning Department staff will not process the Form prior to fees being paid to the City.

Prepared By		Developer/Applicant	
Company:	Linscott, Law & Greenspan, Engineers	Company:	PK Architecture
Contact:	Daniel A. Kloos, P.E.	Contact:	Jose Tamayo
Address:	2 Executive Circle, #250, Irvine, CA 92614	Address:	29619 Agoura Road, Agoura Hills, CA 91301
Phone:	(949) 825-6175, ext. 238	Phone:	(818) 584-0057
Email:	kloos@llgengineers.com	Email:	jtamayo@pkarchitecture.net
Date:	5/4/2023	Date:	5/4/2023
Approved by:			
Perris Planning Division	Date	Perris City Engineer	Date

