

# Master Project Specific Water Quality Management Plan

A Template for Projects located within the **Santa Ana Watershed** Region of Riverside County

**Project Title:** Ramona Gateway Commerce Center

**Development No:** P21-00013

**Design Review/Case No:** P21-00013

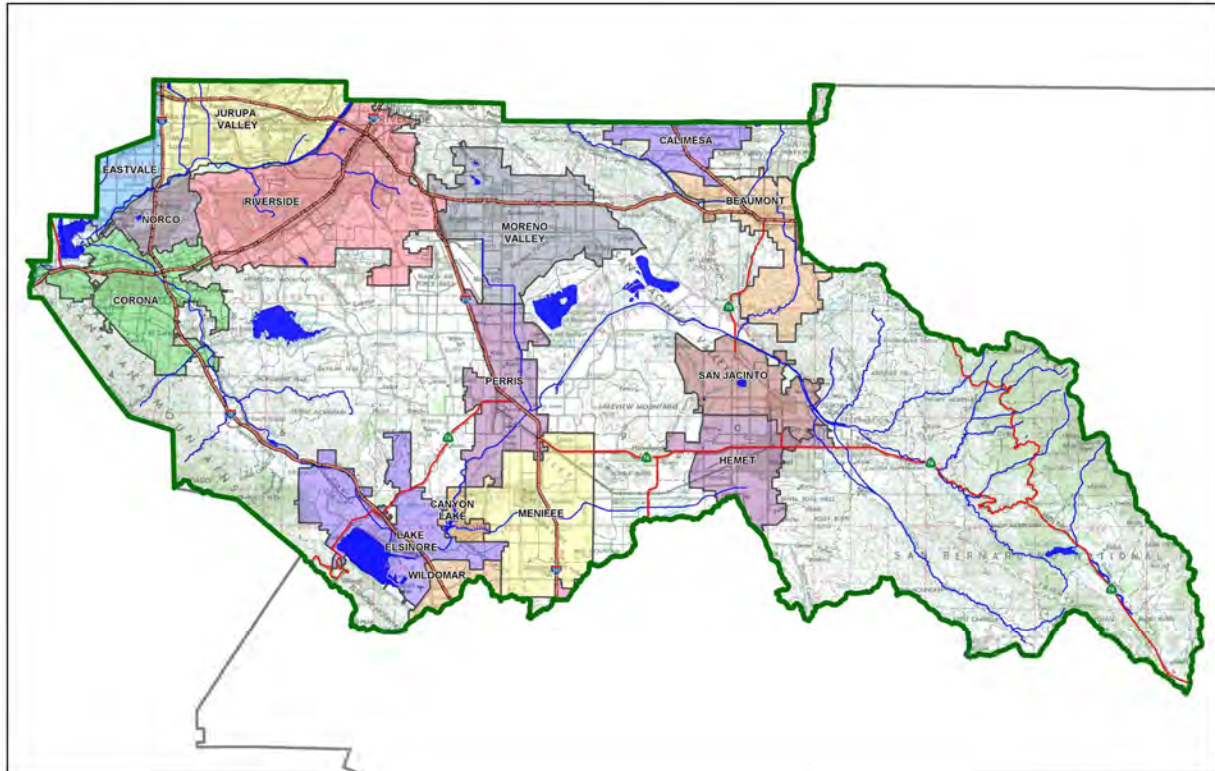

- Preliminary
- Final

**Original Date Prepared:** Sept, 2021

**Revision Date(s):** Jan, 2022  
Jul, 2022, Sept 2022

*Prepared for Compliance with*  
**Regional Board Order No. R8-2010-0033**  
**Template revised June 30, 2016**

## Contact Information:

**Prepared for:**  
Perris Landco, LLC  
201 Spear Street  
Suite 1100  
San Francisco, CA  
312-576-4291

**Prepared by:**  
PBLA Engineering, Inc.  
1809 E. Dyer Rd., Ste 301  
Santa Ana, CA 92705  
888-714-9642

## A Brief Introduction

This Master Project-Specific WQMP Template for the **Santa Ana Region** has been prepared to help guide you in documenting compliance for your project. Because this document has been designed to specifically document compliance, you will need to utilize the WQMP Guidance Document as your “how-to” manual to help guide you through this process. Both the Template and Guidance Document go hand-in-hand, and will help facilitate a well prepared Project-Specific WQMP. Below is a flowchart for the layout of this Template that will provide the steps required to document compliance.

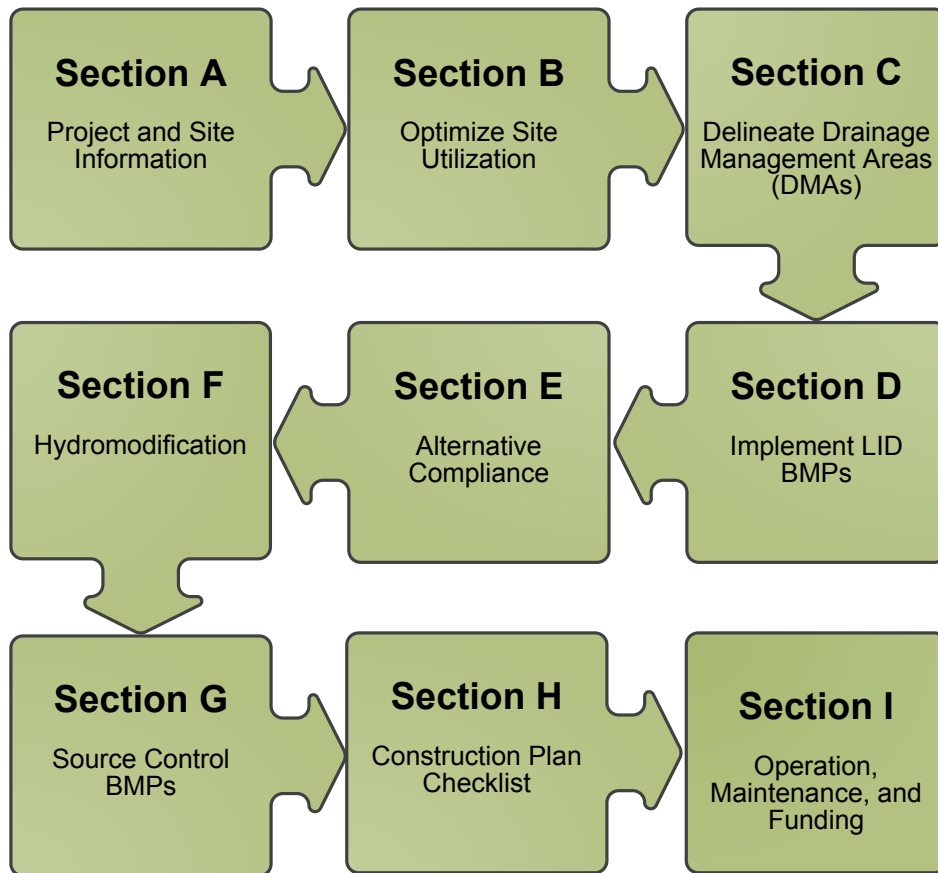

## OWNER'S CERTIFICATION

This Master Project-Specific Water Quality Management Plan (WQMP) has been prepared for Ramona Gateway Commerce Center, by PBLA Engineering, Inc. for the Ramona Gateway Commerce Center project (P21-00013).

This WQMP is intended to comply with the requirements of City of Perris for Municipal Code Section 1194 which includes the requirement for the preparation and implementation of a Project-Specific WQMP.

The undersigned, while owning the property/project described in the preceding paragraph, shall be responsible for the implementation and funding of this WQMP and will ensure that this WQMP is amended as appropriate to reflect up-to-date conditions on the site. In addition, the property owner accepts responsibility for interim operation and maintenance of Stormwater BMPs until such time as this responsibility is formally transferred to a subsequent owner. This WQMP will be reviewed with the facility operator, facility supervisors, employees, tenants, maintenance and service contractors, or any other party (or parties) having responsibility for implementing portions of this WQMP. At least one copy of this WQMP will be maintained at the project site or project office in perpetuity. The undersigned is authorized to certify and to approve implementation of this WQMP. The undersigned is aware that implementation of this WQMP is enforceable under Perris Water Quality Ordinance (Municipal Code Section 1194).

"I, the undersigned, certify under penalty of law that the provisions of this WQMP have been reviewed and accepted and that the WQMP will be transferred to future successors in interest."

\_\_\_\_\_  
Owner's Signature

\_\_\_\_\_  
Date

\_\_\_\_\_  
Owner's Printed Name

\_\_\_\_\_  
Owner's Title/Position

## PREPARER'S CERTIFICATION

"The selection, sizing and design of stormwater treatment and other stormwater quality and quantity control measures in this plan meet the requirements of Regional Water Quality Control Board Order No. **R8-2010-0033** and any subsequent amendments thereto."

\_\_\_\_\_  
Preparer's Signature

\_\_\_\_\_  
Date

\_\_\_\_\_  
Preparer's Printed Name

\_\_\_\_\_  
Preparer's Title/Position

Preparer's Licensure:

## Table of Contents

Section A: Project and Site Information.....	6
A.1 Maps and Site Plans .....	9
A.2 Identify Receiving Waters .....	9
A.3 Additional Permits/Approvals required for the Project: .....	10
Section B: Optimize Site Utilization (LID Principles) .....	11
Section C: Delineate Drainage Management Areas (DMAs).....	13
Section D: Implement LID BMPs .....	15
D.1 Infiltration Applicability .....	15
D.2 Harvest and Use Assessment.....	16
D.3 Bioretention and Biotreatment Assessment .....	18
D.4 Feasibility Assessment Summaries .....	19
D.5 LID BMP Sizing .....	20
Section E: Alternative Compliance (LID Waiver Program) .....	22
E.1 Identify Pollutants of Concern .....	23
E.2 Stormwater Credits .....	24
E.3 Sizing Criteria.....	24
E.4 Treatment Control BMP Selection .....	25
Section F: Hydromodification .....	26
F.1 Hydrologic Conditions of Concern (HCOC) Analysis .....	26
F.2 HCOC Mitigation.....	27
Section G: Source Control BMPs.....	28
Section H: Construction Plan Checklist .....	32
Section I: Operation, Maintenance and Funding.....	33

## List of Tables

Table A.1 Identification of Receiving Waters.....	9
Table A.2 Other Applicable Permits.....	10
Table C.1 DMA Classifications.....	13
Table C.2 Type 'A', Self-Treating Areas.....	14
Table C.3 Type 'B', Self-Retaining Areas.....	14
Table C.4 Type 'C', Areas that Drain to Self-Retaining Areas.....	14
Table C.5 Type 'D', Areas Draining to BMPs.....	14
Table D.1 Infiltration Feasibility.....	15
Table D.2 LID Prioritization Summary Matrix.....	19
Table D.3 DCV Calculations for LID BMPs.....	20
Table D.4.1 DCV Calculations for LID BMPs.....	20
Table D.5.1 DCV Calculations for LID BMPs.....	20
Table E.1 Potential Pollutants by Land Use Type.....	23
Table E.2 Water Quality Credits.....	24
Table E.3 Treatment Control BMP Sizing.....	24
Table E.4 Treatment Control BMP Selection.....	25
Table F.1 Hydrologic Conditions of Concern Summary.....	26
Table G.1 Permanent and Operational Source Control Measures.....	28
Table H.1 Construction Plan Cross-reference.....	32

## List of Appendices

Appendix 1: Maps and Site Plans.....	34
Appendix 2: Construction Plans.....	35
Appendix 3: Soils Information.....	36
Appendix 4: Historical Site Conditions.....	37
Appendix 5: LID Infeasibility.....	38
Appendix 6: BMP Design Details.....	39
Appendix 7: Hydromodification.....	40
Appendix 8: Source Control.....	41
Appendix 9: O&M.....	42
Appendix 10: Educational Materials.....	- 43 -
Appendix 11: Modular Wetlands Sample.....	- 43 -

## Section A: Project and Site Information

PROJECT INFORMATION	
Type of Project:	Light Industrial and Retail
Planning Area:	Mead Valley
Community Name:	Perris
Development Name:	Ramona Gateway Commerce Center
PROJECT LOCATION	
Latitude & Longitude (DMS): 33° 50' 34", 117° 14' 45"	
Project Watershed and Sub-Watershed: San Jacinto, Perris Valley	
Gross Acres: 50.0	
APN(s): 317-120-021 317-130-017, 021, 025, 048	
Map Book and Page No.: Pg 777, Grid E2	
PROJECT CHARACTERISTICS	
Proposed or Potential Land Use(s)	Industrial & Retail
Proposed or Potential SIC Code(s)	4225, 4214, 5399
Area of Impervious Project Footprint (SF)	0
Total Area of <u>proposed</u> Impervious Surfaces within the Project Footprint (SF)/or Replacement	1,774,149
Does the project consist of offsite road improvements?	<input checked="" type="checkbox"/> Y <input type="checkbox"/> N
Does the project propose to construct unpaved roads?	<input type="checkbox"/> Y <input checked="" type="checkbox"/> N
Is the project part of a larger common plan of development (phased project)?	<input type="checkbox"/> Y <input checked="" type="checkbox"/> N
EXISTING SITE CHARACTERISTICS	
Total area of <u>existing</u> Impervious Surfaces within the Project limits Footprint (SF)	0
Is the project located within any MSHCP Criteria Cell?	<input type="checkbox"/> Y <input checked="" type="checkbox"/> N
If so, identify the Cell number:	N/A
Are there any natural hydrologic features on the project site?	<input type="checkbox"/> Y <input checked="" type="checkbox"/> N
Is a Geotechnical Report attached?	<input checked="" type="checkbox"/> Y <input type="checkbox"/> N
If no Geotech. Report, list the NRCS soils type(s) present on the site (A, B, C and/or D)	B
What is the Water Quality Design Storm Depth for the project?	0.58"

This is a Master PWQMP for the entire Site. Each Parcel or sub-site will be required to submit a final WQMP in concert with final grading & drainage plans for final development.

Perris Landco, LLC is proposing to develop a multi building commercial/retail and industrial project on approximately 50.0 acres of land in the City of Perris, CA. The property is located on the south side of the Ramona Expressway between Nevada Avenue and Webster Avenue 1/8 mile east of Interstate 215.

The property is vacant and unimproved. The natural drainage pattern flows generally from west to east as surface flows. The site was formerly used as agriculture but has been fallow for some time. The proposed development will consist of a retail component on the northerly 6.95 acres, and the remaining property to the south will be developed as a single industrial logistics 850,224 sf building.

Onsite drainage design will consist of various inlets at low points around the site and these inlets will connect to underground detention systems. The Industrial site will have one underground system on

each side of the building in the truck court areas, and the Retail site will have its own separate system and underground detention. The detention systems will capture the required Water Quality volume as well as attenuate peak storm flows to ensure that the developed condition does not exceed the existing condition peak runoff rate. See the Appendix 6 for the calculated treatment volumes for each area.

The site is not conducive to infiltration based on the results of infiltration testing provided by the Geotechnical Engineer. The Site is designed to store the required Water Quality Volume underground and then convey that volume via pumps to be treated with a Modular Wetlands Units located on the southeast area of the retail portion and the northwest and northeast areas of the industrial portion.

Modular Wetlands Systems (MWS) operate by gravity and incorporates pretreatment & biofiltration. Stormwater and other pollutants all enter the pretreatment chamber first. The larger material remains contained within the pretreatment stage as stormwater travels through the pre-filter boxes and on to the biofiltration chamber. This design enhances treatment, prevents clogging, and expedites the maintenance process. The sizing of the MWS for each DMA area will be based on a maximum 48 hour drawdown period. The exact sizing and details for these units will be provided with final construction documents.

As water leaves the pre-filter box and enters the biofiltration chamber, it initially fills the void space at the perimeter of the biofiltration chamber. The water's horizontal force grows, pushing it inward toward the centrally located vertical drain pipe, and out to discharge. A full description and details for efficiency are provided in Appendix 6.

The conceptual site plan includes up to 37,215 sf of retail space consisting of three drive-thru restaurant buildings; two multi-tenant buildings, one of which would include a drive-thru; one coffee shop with drive-thru; one convenience store with a gas station; and one drive-thru express carwash facility. Table 3-1, Retail Building Summary, provides a breakdown of the proposed retail use. The proposed buildings would comply with the commercial development standards outlined in Table 4.0-1, Development Standards by Land Use, of the PVCCSP, including, but not limited to floor-to-area ratio (FAR) (0.75 maximum), lot coverage (50% maximum), and height requirements (45 feet maximum).

DMA Summary Table:

<b>LOCATION WITHIN PROJECT</b>	<b>DMA DESIGNATION</b>	<b>AREA TRIBUTARY TO TREATMENT</b>	<b>DCV/Qbmp</b>	<b>BMP ID</b>
FUELING STATION RETAIL BLD 1	A	54,514	2,043 CF	"U/G-A" & "MW-A"
DRIVE-THRU RETAIL BLD 2	B	11,827 SF	0.1 CFS	"LWU - B"
DRIVE-THRU RETAIL BLD 3	C	13,693 SF	0.1 CFS	"LWU-C"
COMMON AREA & DRIVES	D	16,697	0.1 CFS	"LWU-D"
DRIVE-THRU RETAIL BLD 4	E	18,659 SF	0.1 CFS	"LWU-E"
DRIVE-THRU RETAIL BLD 5	F	19,674 SF	0.1 CFS	"LWU-F"

LOCATION WITHIN PROJECT	DMA DESIGNATION	AREA TRIBUTARY TO TREATMENT	DCV/Qbmp	BMP ID
DRIVE-THRU RETAIL BLD 6	G	14,875 SF	0.1 CFS	"LWU-G"
DRIVE-THRU RETAIL BLD 7	H	22,484 SF	0.1 CFS	"LWU-H"
COMMON AREA & DRIVES	I	97,543 SF	4,256 CF	"U/G-I" & "MW-I"
INDUSTRIAL BLD 1 - WEST	J	905,010 SF	35,220 CF	"U/G-J" & "MW-J"
INDUSTRIAL BLD 1 - EAST	K	766,867 SF	31,519 CF	"U/G-K" & "MW-K"
COMMON AREA & DRIVES	L	12,667 SF	0.1 CFS	"LWU-L"

#### Fueling Station/Convenience Store

This parcel is self-managing and has separate drainage and water quality treatment systems. Fueling area is also isolated from site drainage with a trench drain and isolated sump at the downstream edge of the fueling slab.

#### Regional Drainage

This project is also downstream of the Perris Valley Master Plan of Drainage (MPD) Line E culvert that daylight on the eastern side of Interstate 215. The ultimate flow rate of this line delivers 1000 cfs per the aforementioned MPD onto the existing ground and is returned to a surface drainage state after the flows exit the existing box culvert. The Master Plan indicates that there will be a detention basin at the location of the Line E outlet from the freeway. The Master Planned Detention Basin is slated to be located on the property to the west of Nevada on property that is owned by a different entity, and as of current, the status of the design and construction of that basin remains unknown.

Since the Ramona Gateway Commerce Center is east of Nevada Avenue, this ultimate Line E flow is directly tributary to this project as un-detained, bulk sheet flow crossing Nevada Avenue on the western edge of the Property. To mitigate this condition, the project proponent will install a 60" RCP Storm Drain that will eventually act as the ultimate outlet storm drain line from the future detention basin. This storm drain will be designed to RCFCD standards and be transferred to the City for operation and maintenance. The storm drain will be located in Nevada at its upstream end and run northerly to the retail parcels, turn easterly and ultimately connect to the existing 60" storm drain in Ramona Expressway.

In addition to the ultimate storm drain line being installed with this project, an emergency bypass channel is planned to pick-up any remaining sheet-flow runoff that does not enter the proposed 60" storm drain and crosses over Nevada toward the project. The Nevada Avenue crossing is proposed to be a full section concrete "Arizona Crossing" that will convey excess sheet flow from the west side of Nevada to the east, and the Bypass Channel. The channel is planned to be a trapezoidal channel with an 11-foot wide bottom and 1.75:1 side slopes and will be constructed of concrete. The size and slope of the channel will safely convey this remainder flow through the site and deliver it back to Webster Avenue. At the downstream terminus of the bypass channel, there will be a stilling basin that will be

about 7 feet deep and approximately 39 feet wide. This basin calms the flows exiting the trapezoidal channel and reduces velocities dramatically before the basin is overtopped and water sheet flows to Webster Ave. Please note that this condition will occur only in the design storm 100-year event. The majority of storms will not produce enough runoff to trigger the basin overflow condition. There will also be an inlet provided at the downstream end of the channel to drain low flows to the existing storm drain in Webster Ave.

## A.1 Maps and Site Plans

When completing your Project-Specific WQMP, include a map of the local vicinity and existing site. In addition, include all grading, drainage, landscape/plant palette and other pertinent construction plans in Appendix 2. At a **minimum**, your WQMP Site Plan should include the following:

- Drainage Management Areas
- Proposed Structural BMPs
- Drainage Path
- Drainage Infrastructure, Inlets, Overflows
- Source Control BMPs
- Buildings, Roof Lines, Downspouts
- Impervious Surfaces
- Standard Labeling
- BMP Locations (Lat/Long)

Use your discretion on whether or not you may need to create multiple sheets or can appropriately accommodate these features on one or two sheets. Keep in mind that the Co-Permittee plan reviewer must be able to easily analyze your project utilizing this template and its associated site plans and maps.

## A.2 Identify Receiving Waters

Using Table A.1 below, list in order of upstream to downstream, the receiving waters that the project site is tributary to. Continue to fill each row with the Receiving Water’s 303(d) listed impairments (if any), designated beneficial uses, and proximity, if any, to a RARE beneficial use. Include a map of the receiving waters in Appendix 1.

**Table A.1** Identification of Receiving Waters

Receiving Waters	EPA 303(d) Approved List Impairments	Designated Beneficial Uses	Proximity to RARE Beneficial Use
Perris Valley MPD Line “E”	None Listed	N/A	N/A
Perris Valley Storm Drain	None Listed	body contact recreation (REC1), non-body contact recreation (REC2), warm freshwater aquatic habitat (WARM), wildlife habitat (WILD), rare, threatened or endangered species habitat (RARE)	2.7 mi
San Jacinto River Reach 3	None Listed	agricultural water supply (AGR), groundwater recharge (GWR), body contact recreation (REC1), non-body contact recreation (REC2), warm freshwater aquatic habitat (WARM), wildlife habitat (WILD), rare, threatened or endangered species habitat (RARE)	5.5 mi
Railroad Canyon / Canyon Lake	Nutrients	Municipal Domestic supply (MUN), agricultural water supply (AGR), groundwater recharge (GWR), body contact recreation (REC1), non-body contact recreation (REC2), commercial and sport fishing (COMM), warm freshwater aquatic habitat (WARM), wildlife habitat (WILD), rare, threatened or endangered species habitat (RARE)	15.1 mi

San Jacinto River Reach 1	None Listed	body contact recreation (REC1), non-body contact recreation (REC2), commercial and sport fishing (COMM), warm freshwater aquatic habitat (WARM), wildlife habitat (WILD), rare, threatened or endangered species habitat (RARE)	12.3 mi
Lake Elsinore	PCBs, Nutrients, Low Dissolved Oxygen, Toxicity, DDT	Municipal Domestic supply (MUN), agricultural water supply (AGR), groundwater recharge (GWR), body contact recreation (REC1), non-body contact recreation (REC2), commercial and sport fishing (COMM), warm freshwater aquatic habitat (WARM), wildlife habitat (WILD), rare, threatened or endangered species habitat (RARE)	25.0 mi

### A.3 Additional Permits/Approvals required for the Project:

Table A.2 Other Applicable Permits

Agency	Permit Required	
State Department of Fish and Game, 1602 Streambed Alteration Agreement	<input checked="" type="checkbox"/> Y	<input type="checkbox"/> N
State Water Resources Control Board, Clean Water Act (CWA) Section 401 Water Quality Cert.	<input type="checkbox"/> Y	<input checked="" type="checkbox"/> N
US Army Corps of Engineers, CWA Section 404 Permit	<input type="checkbox"/> Y	<input checked="" type="checkbox"/> N
US Fish and Wildlife, Endangered Species Act Section 7 Biological Opinion	<input type="checkbox"/> Y	<input checked="" type="checkbox"/> N
Statewide Construction General Permit Coverage	<input checked="" type="checkbox"/> Y	<input type="checkbox"/> N
Statewide Industrial General Permit Coverage (Dependent On Tenant)	<input checked="" type="checkbox"/> Y	<input type="checkbox"/> N
Western Riverside MSHCP Consistency Approval (e.g., JPR, DBESP)	<input checked="" type="checkbox"/> Y	<input type="checkbox"/> N
Other (please list in the space below as required)	<input type="checkbox"/> Y	<input checked="" type="checkbox"/> N

If yes is answered to any of the questions above, the Co-Permittee may require proof of approval/coverage from those agencies as applicable including documentation of any associated requirements that may affect this Project-Specific WQMP.

## Section B: Optimize Site Utilization (LID Principles)

Review of the information collected in Section 'A' will aid in identifying the principal constraints on site design and selection of LID BMPs as well as opportunities to reduce imperviousness and incorporate LID Principles into the site and landscape design. For example, **constraints** might include impermeable soils, high groundwater, groundwater pollution or contaminated soils, steep slopes, geotechnical instability, high-intensity land use, heavy pedestrian or vehicular traffic, utility locations or safety concerns. **Opportunities** might include existing natural areas, low areas, oddly configured or otherwise unbuildable parcels, easements and landscape amenities including open space and buffers (which can double as locations for bioretention BMPs), and differences in elevation (which can provide hydraulic head). Prepare a brief narrative for each of the site optimization strategies described below. This narrative will help you as you proceed with your LID design and explain your design decisions to others.

The 2010 Santa Ana MS4 Permit further requires that LID Retention BMPs (Infiltration Only or Harvest and Use) be used unless it can be shown that those BMPs are infeasible. Therefore, it is important that your narrative identify and justify if there are any constraints that would prevent the use of those categories of LID BMPs. Similarly, you should also note opportunities that exist which will be utilized during project design. Upon completion of identifying Constraints and Opportunities, include these on your WQMP Site plan in Appendix 1.

Consideration of "highest and best use" of the discharge should also be considered. For example, Lake Elsinore is evaporating faster than runoff from natural precipitation can recharge it. Requiring infiltration of 85% of runoff events for projects tributary to Lake Elsinore would only exacerbate current water quality problems associated with Pollutant concentration due to lake water evaporation. In cases where rainfall events have low potential to recharge Lake Elsinore (i.e. no hydraulic connection between groundwater to Lake Elsinore, or other factors), requiring infiltration of Urban Runoff from projects is counterproductive to the overall watershed goals. Project proponents, in these cases, would be allowed to discharge Urban Runoff, provided they used equally effective filtration-based BMPs.

### Site Optimization

The following questions are based upon Section 3.2 of the WQMP Guidance Document. Review of the WQMP Guidance Document will help you determine how best to optimize your site and subsequently identify opportunities and/or constraints, and document compliance.

Did you identify and preserve existing drainage patterns? If so, how? If not, why?

*Current drainage pattern directs surface flows generally west to east to approximately 400 feet south of the intersection of Ramona Expressway & Webster Avenue. The proposed development will perpetuate the existing drainage pattern.*

Did you identify and protect existing vegetation? If so, how? If not, why?

*This site is a former agricultural site, and the proposed development will disturb the entire site.*

Did you identify and preserve natural infiltration capacity? If so, how? If not, why?

*No. Measured infiltration rates were no more than 0.5 in/hr due to low permeability soils and shallow bedrock. The site design incorporates underground detention and Water Quality treatment with Modular Wetlands Units.*

Did you identify and minimize impervious area? If so, how? If not, why?

*Every effort was taken to minimize impervious area and comply with Riverside County minimum requirements for parking, access, circulation, and fire requirements.*

Did you identify and disperse runoff to adjacent pervious areas? If so, how? If not, why?

*Retail development will incorporate run-off dispersion, the Distribution / Logistical development is more difficult to employ this effectively, but entry areas will shed toward adjacent landscape. Every effort will be employed to incorporate this design consideration in the Retail Area.*

## Section C: Delineate Drainage Management Areas (DMAs)

Utilizing the procedure in Section 3.3 of the WQMP Guidance Document which discusses the methods of delineating and mapping your project site into individual DMAs, complete Table C.1 below to appropriately categorize the types of classification (e.g., Type A, Type B, etc.).

Table C.1 DMA Classifications

DMA Name or ID	Surface Type(s) <sup>12</sup>	Area (Sq. Ft.)	DMA Type
DMA - A	Roof	11,579	Type D
DMA - A	Paving	34,800	Type D
DMA - A	Landscape	8,135	Type D
DMA - B	Roof	2400	Type D
DMA - B	Paving	8,359	Type D
DMA - B	Landscape	1,068	Type D
DMA - C	Roof	6,000	Type D
DMA - C	Paving	5,778	Type D
DMA - C	Landscape	1,915	Type D
DMA - D	Roof	0	Type D
DMA - D	Paving	11,697	Type D
DMA - D	Landscape	5,182	Type D
DMA - E	Roof	4,500	Type D
DMA - E	Paving	11,540	Type D
DMA - E	Landscape	2,619	Type D
DMA - F	Roof	4500	Type D
DMA - F	Paving	11,607	Type D
DMA - F	Landscape	3,567	Type D
DMA - G	Roof	5,500	Type D
DMA - G	Paving	6,085	Type D
DMA - G	Landscape	3,290	Type D
DMA - H	Roof	4,500	Type D
DMA - H	Paving	8,904	Type D
DMA - H	Landscape	9,080	Type D
DMA - I	Roof	0	Type D
DMA - I	Paving	88,577	Type D
DMA - I	Landscape	8,966	Type D
DMA - J	Roof	438,446	Type D
DMA - J	Paving	365,944	Type D
DMA - J	Landscape	101,182	Type D
DMA - K	Roof	419,494	Type D
DMA - K	Paving	306,547	Type D
DMA - K	Landscape	40,615	Type D
DMA - L	Roof	0	Type D
DMA - L	Paving	8,441	Type D
DMA - L	Landscape	4,226	Type D
DMA - E	Landscape	126,129	Type A

<sup>1</sup>Reference Table 2-1 in the WQMP Guidance Document to populate this column

<sup>2</sup>If multi-surface provide back-up

**Table C.2 Type 'A', Self-Treating Areas**

DMA Name or ID	Area (Sq. Ft.)	Stabilization Type	Irrigation Type (if any)
DMA-E	126,129	Landscape	Heads & bubblers

**Table C.3 Type 'B', Self-Retaining Areas**

Self-Retaining Area				Type 'C' DMAs that are draining to the Self-Retaining Area		
DMA Name/ ID	Post-project surface type	Area (square feet)	Storm Depth (inches)	DMA Name / ID	[C] from Table C.4 = [C]	Required Retention Depth (inches) [D]
		[A]	[B]			

$$[D] = [B] + \frac{[B] \cdot [C]}{[A]}$$

**Table C.4 Type 'C', Areas that Drain to Self-Retaining Areas**

DMA					Receiving Self-Retaining DMA		
DMA Name/ ID	Area (square feet)	Post-project surface type	Impervious fraction	Product	DMA name /ID	Area (square feet)	Ratio
	[A]		[B]	[C] = [A] x [B]		[D]	[C]/[D]

**Table C.5 Type 'D', Areas Draining to BMPs**

DMA Name or ID	BMP Name or ID
DMA – A	U/G STORAGE & MODULAR WETLANDS UNITS
DMA – B	LINEAR MODULAR WETLANDS UNITS
DMA – C	LINEAR MODULAR WETLANDS UNITS
DMA – D	LINEAR MODULAR WETLANDS UNITS
DMA – E	LINEAR MODULAR WETLANDS UNITS
DMA – F	LINEAR MODULAR WETLANDS UNITS
DMA – G	LINEAR MODULAR WETLANDS UNITS
DMA – H	LINEAR MODULAR WETLANDS UNITS
DMA – I	U/G STORAGE & MODULAR WETLANDS UNITS
DMA – J	U/G STORAGE & MODULAR WETLANDS UNITS
DMA – K	U/G STORAGE & MODULAR WETLANDS UNITS
DMA – L	LINEAR MODULAR WETLANDS UNITS

*Note: More than one drainage management area can drain to a single LID BMP, however, one drainage management area may not drain to more than one BMP.*

## Section D: Implement LID BMPs

### D.1 Infiltration Applicability

Is there an approved downstream ‘Highest and Best Use’ for stormwater runoff (see discussion in Chapter 2.4.4 of the WQMP Guidance Document for further details)?  Y  N

If yes has been checked, Infiltration BMPs shall not be used for the site; proceed to section D.3

If no, continue working through this section to implement your LID BMPs. It is recommended that you contact your Co-Permittee to verify whether or not your project discharges to an approved downstream ‘Highest and Best Use’ feature.

#### Geotechnical Report

A Geotechnical Report or Phase I Environmental Site Assessment may be required by the Copermitee to confirm present and past site characteristics that may affect the use of Infiltration BMPs. In addition, the Co-Permittee, at their discretion, may not require a geotechnical report for small projects as described in Chapter 2 of the WQMP Guidance Document. If a geotechnical report has been prepared, include it in Appendix 3. In addition, if a Phase I Environmental Site Assessment has been prepared, include it in Appendix 4.

Is this project classified as a small project consistent with the requirements of Chapter 2 of the WQMP Guidance Document?  Y  N

#### Infiltration Feasibility

Table D.1 below is meant to provide a simple means of assessing which DMAs on your site support Infiltration BMPs and is discussed in the WQMP Guidance Document in Chapter 2.4.5. Check the appropriate box for each question and then list affected DMAs as applicable. If additional space is needed, add a row below the corresponding answer.

Table D.1 Infiltration Feasibility

Does the project site...	YES	NO
...have any DMAs with a seasonal high groundwater mark shallower than 10 feet? If Yes, list affected DMAs:		X
...have any DMAs located within 100 feet of a water supply well? If Yes, list affected DMAs:		X
...have any areas identified by the geotechnical report as posing a public safety risk where infiltration of stormwater could have a negative impact? If Yes, list affected DMAs:		X
...have measured in-situ infiltration rates of less than 1.6 inches / hour? If Yes, list affected DMAs: D-1 & D-2 ALL (Rates vary between 0.3-0.5 inches / hour)	X	
...have significant cut and/or fill conditions that would preclude in-situ testing of infiltration rates at the final infiltration surface? If Yes, list affected DMAs:		X
...geotechnical report identify other site-specific factors that would preclude effective and safe infiltration? Describe here: Shallow Bedrock, low permeability/ dense soils	X	

If you answered “Yes” to any of the questions above for any DMA, Infiltration BMPs should not be used for those DMAs and you should proceed to the assessment for Harvest and Use below.

## D.2 Harvest and Use Assessment

Please check what applies:

- Reclaimed water will be used for the non-potable water demands for the project.
- Downstream water rights may be impacted by Harvest and Use as approved by the Regional Board (verify with the Copermittee).
- The Design Capture Volume will be addressed using Infiltration Only BMPs. In such a case, Harvest and Use BMPs are still encouraged, but it would not be required if the Design Capture Volume will be infiltrated or evapotranspired.

If any of the above boxes have been checked, Harvest and Use BMPs need not be assessed for the site. If none of the above criteria applies, follow the steps below to assess the feasibility of irrigation use, toilet use and other non-potable uses (e.g., industrial use).

### Irrigation Use Feasibility

Complete the following steps to determine the feasibility of harvesting stormwater runoff for Irrigation Use BMPs on your site:

Step 1: Identify the total area of irrigated landscape on the site, and the type of landscaping used.

*Total Area of Irrigated Landscape: 6.72*

*Type of Landscaping (Conservation Design or Active Turf): Conservation Design*

Step 2: Identify the planned total of all impervious areas on the proposed project from which runoff might be feasibly captured and stored for irrigation use. Depending on the configuration of buildings and other impervious areas on the site, you may consider the site as a whole, or parts of the site, to evaluate reasonable scenarios for capturing and storing runoff and directing the stored runoff to the potential use(s) identified in Step 1 above.

*Total Area of Impervious Surfaces: 38.11*

Step 3: Cross reference the Design Storm depth for the project site (see Exhibit A of the WQMP Guidance Document) with the left column of Table 2-3 in Chapter 2 to determine the minimum area of Effective Irrigated Area per Tributary Impervious Area (EIATIA).

*Enter your EIATIA factor: 0.58*

Step 4: Multiply the unit value obtained from Step 3 by the total of impervious areas from Step 2 to develop the minimum irrigated area that would be required.

*Minimum required irrigated area: 22.1*

Step 5: Determine if harvesting stormwater runoff for irrigation use is feasible for the project by comparing the total area of irrigated landscape (Step 1) to the minimum required irrigated area (Step 4).

Minimum required irrigated area (Step 4)	Available Irrigated Landscape (Step 1)
22.1	6.72

## Toilet Use Feasibility

Complete the following steps to determine the feasibility of harvesting stormwater runoff for toilet flushing uses on your site:

Step 1: Identify the projected total number of daily toilet users during the wet season, and account for any periodic shut downs or other lapses in occupancy:

*Projected Number of Daily Toilet Users: 909*

*Project Type: Industrial / Retail*

Step 2: Identify the planned total of all impervious areas on the proposed project from which runoff might be feasibly captured and stored for toilet use. Depending on the configuration of buildings and other impervious areas on the site, you may consider the site as a whole, or parts of the site, to evaluate reasonable scenarios for capturing and storing runoff and directing the stored runoff to the potential use(s) identified in Step 1 above.

*Total Area of Impervious Surfaces: 38.11*

Step 3: Enter the Design Storm depth for the project site (see Exhibit A) into the left column of Table 2-2 in Chapter 2 to determine the minimum number of toilet users per tributary impervious acre (TUTIA).

*Enter your TUTIA factor: 0.58*

Step 4: Multiply the unit value obtained from Step 3 by the total of impervious areas from Step 2 to develop the minimum number of toilet users that would be required.

*Minimum number of toilet users: 22*

Step 5: Determine if harvesting stormwater runoff for toilet flushing use is feasible for the project by comparing the Number of Daily Toilet Users (Step 1) to the minimum required number of toilet users (Step 4).

<u>Minimum required Toilet Users (Step 4)</u>	<u>Projected number of toilet users (Step 1)</u>
22	909

**Note: County Health Department has not authorized storm water for toilet use and therefore will not be considered.**

## Other Non-Potable Use Feasibility

Are there other non-potable uses for stormwater runoff on the site (e.g. industrial use)? See Chapter 2 of the Guidance for further information. If yes, describe below. If no, write N/A.

N/A

Step 1: Identify the projected average daily non-potable demand, in gallons per day, during the wet season and accounting for any periodic shut downs or other lapses in occupancy or operation.

*Average Daily Demand: Projected Average Daily Use (gpd)*

Step 2: Identify the planned total of all impervious areas on the proposed project from which runoff might be feasibly captured and stored for the identified non-potable use. Depending on the configuration of buildings and other impervious areas on the site, you may consider the site as a whole, or parts of the site, to evaluate reasonable scenarios for capturing and storing runoff and directing the stored runoff to the potential use(s) identified in Step 1 above.

*Total Area of Impervious Surfaces: Insert Area (Acres)*

Step 3: Enter the Design Storm depth for the project site (see Exhibit A) into the left column of Table 2-4 in Chapter 2 to determine the minimum demand for non-potable uses per tributary impervious acre.

*Enter the factor from Table 2-4: Enter Value*

Step 4: Multiply the unit value obtained from Step 3 by the total of impervious areas from Step 2 to develop the minimum number of gallons per day of non-potable use that would be required.

*Minimum required use: Minimum use required (gpd)*

Step 5: Determine if harvesting stormwater runoff for other non-potable use is feasible for the project by comparing the projected average daily use (Step 1) to the minimum required non-potable use (Step 4).

<b>Minimum required non-potable use (Step 4)</b>	<b>Projected average daily use (Step 1)</b>
Minimum use required (gpd)	Projected Average Daily Use (gpd)

If Irrigation, Toilet and Other Use feasibility anticipated demands are less than the applicable minimum values, Harvest and Use BMPs are not required and you should proceed to utilize LID Bioretention and Biotreatment per Section 3.4.2 of the WQMP Guidance Document.

### **D.3 Bioretention and Biotreatment Assessment**

Other LID Bioretention and Biotreatment BMPs as described in Chapter 2.4.7 of the WQMP Guidance Document are feasible on nearly all development sites with sufficient advance planning.

*Select one of the following:*

LID Bioretention/Biotreatment BMPs will be used for some or all DMAs of the project as noted below in Section D.4 (note the requirements of Section 3.4.2 in the WQMP Guidance Document).

A site-specific analysis demonstrating the technical infeasibility of all LID BMPs has been performed and is included in Appendix 5. If you plan to submit an analysis demonstrating the technical infeasibility of LID BMPs, request a pre-submittal meeting with the Copermittee to discuss this option. Proceed to Section E to document your alternative compliance measures.

## D.4 Feasibility Assessment Summaries

From the Infiltration, Harvest and Use, Bioretention and Biotreatment Sections above, complete Table D.2 below to summarize which LID BMPs are technically feasible, and which are not, based upon the established hierarchy.

Table D.2 LID Prioritization Summary Matrix

DMA Name/ID	LID BMP Hierarchy				No LID (Alternative Compliance)
	1. Infiltration	2. Harvest and use	3. Bioretention	4. Biotreatment	
A	<input type="checkbox"/>	<input type="checkbox"/>	<input type="checkbox"/>	<input type="checkbox"/>	<input checked="" type="checkbox"/>
B	<input type="checkbox"/>	<input type="checkbox"/>	<input type="checkbox"/>	<input type="checkbox"/>	<input checked="" type="checkbox"/>
C	<input type="checkbox"/>	<input type="checkbox"/>	<input type="checkbox"/>	<input type="checkbox"/>	<input checked="" type="checkbox"/>
D	<input type="checkbox"/>	<input type="checkbox"/>	<input type="checkbox"/>	<input type="checkbox"/>	<input checked="" type="checkbox"/>
E	<input type="checkbox"/>	<input type="checkbox"/>	<input type="checkbox"/>	<input type="checkbox"/>	<input checked="" type="checkbox"/>
F	<input type="checkbox"/>	<input type="checkbox"/>	<input type="checkbox"/>	<input type="checkbox"/>	<input checked="" type="checkbox"/>
G	<input type="checkbox"/>	<input type="checkbox"/>	<input type="checkbox"/>	<input type="checkbox"/>	<input checked="" type="checkbox"/>
H	<input type="checkbox"/>	<input type="checkbox"/>	<input type="checkbox"/>	<input type="checkbox"/>	<input checked="" type="checkbox"/>
I	<input type="checkbox"/>	<input type="checkbox"/>	<input type="checkbox"/>	<input type="checkbox"/>	<input checked="" type="checkbox"/>
J	<input type="checkbox"/>	<input type="checkbox"/>	<input type="checkbox"/>	<input type="checkbox"/>	<input checked="" type="checkbox"/>
K	<input type="checkbox"/>	<input type="checkbox"/>	<input type="checkbox"/>	<input type="checkbox"/>	<input checked="" type="checkbox"/>
L	<input type="checkbox"/>	<input type="checkbox"/>	<input type="checkbox"/>	<input type="checkbox"/>	<input checked="" type="checkbox"/>

For those DMAs where LID BMPs are not feasible, provide a brief narrative below summarizing why they are not feasible, include your technical infeasibility criteria in Appendix 5, and proceed to Section E below to document Alternative Compliance measures for those DMAs. Recall that each proposed DMA must pass through the LID BMP hierarchy before alternative compliance measures may be considered.

Infiltration is not viable as the primary BMP. Storage & bio-treatment is proposed as alternative compliance.

## D.5 LID BMP Sizing

Each LID BMP must be designed to ensure that the Design Capture Volume will be addressed by the selected BMPs. First, calculate the Design Capture Volume for each LID BMP using the  $V_{BMP}$  worksheet in Appendix F of the LID BMP Design Handbook. Second, design the LID BMP to meet the required  $V_{BMP}$  using a method approved by the Copermittee. Utilize the worksheets found in the LID BMP Design Handbook or consult with your Copermittee to assist you in correctly sizing your LID BMPs. Complete Table D.3 below to document the Design Capture Volume and the Proposed Volume for each LID BMP. Provide the completed design procedure sheets for each LID BMP in Appendix 6. You may add additional rows to the table below as needed.

Table D.3 DCV Calculations for LID BMPs

DMA Type/ID	DMA Area (square feet)	Post-Project Surface Type	Effective Impervious Fraction, $I_f$	DMA Runoff Factor	DMA Areas x Runoff Factor	<b>UNDERGROUND STORAGE</b> <i>U/G - A</i>		
	[A]				[C]			
<b>A</b>		<i>Roof</i>	<i>1.0</i>	<i>0.89</i>		<i>Design Storm Depth (in)</i>	<i>Design Capture Volume, <math>V_{BMP}</math> (cubic feet)</i>	<i>Proposed Volume on Plans (cubic feet)</i>
<b>A</b>		<i>Pavement</i>	<i>1.0</i>	<i>0.89</i>				
<b>A</b>		<i>Landscaping</i>	<i>0.10</i>	<i>0.11</i>				
	229,363				173,131	0.58	8,368	8,400

Table D.3 DCV Calculations for LID BMPs

	DMA Area (square feet)	Post-Project Surface Type	Effective Impervious Fraction, $I_f$	DMA Runoff Factor	DMA Areas x Runoff Factor	<b>UNDERGROUND STORAGE</b> <i>U/G - I</i>		
	[A]				[C]			
<b>I</b>		<i>Roof</i>	<i>1.0</i>	<i>0.89</i>		<i>Design Storm Depth (in)</i>	<i>Design Capture Volume, <math>V_{BMP}</math> (cubic feet)</i>	<i>Proposed Volume on Plans (cubic feet)</i>
<b>I</b>		<i>Pavement</i>	<i>1.0</i>	<i>0.89</i>				
<b>I</b>		<i>Landscaping</i>	<i>0.10</i>	<i>0.11</i>				
	905,572				728,692	0.58	35,220	65,512

Table D.3 DCV Calculations for LID BMPs

	DMA Area (square feet)	Post-Project Surface Type	Effective Impervious Fraction, $I_f$	DMA Runoff Factor	DMA Areas x Runoff Factor	<b>UNDERGROUND STORAGE</b> <i>U/G - J</i>		
	[A]				[C]			
<b>J</b>		<i>Roof</i>	<i>1.0</i>	<i>0.89</i>		<i>Design Storm Depth (in)</i>	<i>Design Capture Volume, <math>V_{BMP}</math> (cubic feet)</i>	<i>Proposed Volume on Plans (cubic feet)</i>
<b>J</b>		<i>Pavement</i>	<i>1.0</i>	<i>0.89</i>				
<b>J</b>		<i>Landscaping</i>	<i>0.10</i>	<i>0.11</i>				
	766,656				652,115	0.58	31,519	65,512

**Table D.3** DCV Calculations for LID BMPs

	DMA Area (square feet)	Post- Project Surface Type	Effective Impervious Fraction, I <sub>f</sub>	DMA Runoff Factor	DMA Areas Runoff Factor <sup>x</sup>	<b>UNDERGROUND STORAGE U/G - K</b>		
	[A]		[B]	[C]	[A] x [C]			
<b>K</b>		<i>Roof</i>	<i>1.0</i>	<i>0.89</i>		<i>Design Storm Depth (in)</i>	<i>Design Capture Volume, V<sub>BMP</sub> (cubic feet)</i>	<i>Proposed Volume on Plans (cubic feet)</i>
<b>K</b>		<i>Pavement</i>	<i>1.0</i>	<i>0.89</i>				
<b>K</b>		<i>Landscaping</i>	<i>0.10</i>	<i>0.11</i>				
	54,514				42,269	0.58	2,043	2,100

[B], [C] is obtained as described in Section 2.3.1 of the WQMP Guidance Document

[E] is obtained from Exhibit A in the WQMP Guidance Document

[G] is obtained from a design procedure sheet, such as in LID BMP Design Handbook and placed in Appendix 6

## Section E: Alternative Compliance (LID Waiver Program)

LID BMPs are expected to be feasible on virtually all projects. Where LID BMPs have been demonstrated to be infeasible as documented in Section D, other Treatment Control BMPs must be used (subject to LID waiver approval by the Copermittee). Check one of the following Boxes:

LID Principles and LID BMPs have been incorporated into the site design to fully address all Drainage Management Areas. No alternative compliance measures are required for this project and thus this Section is not required to be completed.

- Or -

The following Drainage Management Areas are unable to be addressed using LID BMPs. A site-specific analysis demonstrating technical infeasibility of LID BMPs has been approved by the Co-Permittee and included in Appendix 5. Additionally, no downstream regional and/or sub-regional LID BMPs exist or are available for use by the project. The following alternative compliance measures on the following pages are being implemented to ensure that any pollutant loads expected to be discharged by not incorporating LID BMPs, are fully mitigated.

All areas A - L

## E.1 Identify Pollutants of Concern

Utilizing Table A.1 from Section A above which noted your project's receiving waters and their associated EPA approved 303(d) listed impairments, cross reference this information with that of your selected Priority Development Project Category in Table E.1 below. If the identified General Pollutant Categories are the same as those listed for your receiving waters, then these will be your Pollutants of Concern and the appropriate box or boxes will be checked on the last row. The purpose of this is to document compliance and to help you appropriately plan for mitigating your Pollutants of Concern in lieu of implementing LID BMPs.

**Table E.1 Potential Pollutants by Land Use Type**

Priority Development Project Categories and/or Project Features (check those that apply)	General Pollutant Categories							
	Bacterial Indicators	Metals	Nutrients	Pesticides	Toxic Organic Compounds	Sediments	Trash & Debris	Oil & Grease
<input type="checkbox"/> Detached Residential Development	P	N	P	P	N	P	P	P
<input type="checkbox"/> Attached Residential Development	P	N	P	P	N	P	P	P <sup>(2)</sup>
<input checked="" type="checkbox"/> Commercial/Industrial Development	P <sup>(3)</sup>	P	P <sup>(1)</sup>	P <sup>(1)</sup>	P <sup>(5)</sup>	P <sup>(1)</sup>	P	P
<input type="checkbox"/> Automotive Repair Shops	N	P	N	N	P <sup>(4, 5)</sup>	N	P	P
<input checked="" type="checkbox"/> Restaurants (>5,000 ft <sup>2</sup> )	P	N	N	N	N	N	P	P
<input type="checkbox"/> Hillside Development (>5,000 ft <sup>2</sup> )	P	N	P	P	N	P	P	P
<input checked="" type="checkbox"/> Parking Lots (>5,000 ft <sup>2</sup> )	P <sup>(6)</sup>	P	P <sup>(1)</sup>	P <sup>(1)</sup>	P <sup>(4)</sup>	P <sup>(1)</sup>	P	P
<input type="checkbox"/> Retail Gasoline Outlets	N	P	N	N	P	N	P	P
<b>Project Priority Pollutant(s) of Concern</b>	<input type="checkbox"/>	<input type="checkbox"/>	<input checked="" type="checkbox"/>	<input checked="" type="checkbox"/>	<input checked="" type="checkbox"/>	<input type="checkbox"/>	<input type="checkbox"/>	<input type="checkbox"/>

*P = Potential*

*N = Not Potential*

<sup>(1)</sup> *A potential Pollutant if non-native landscaping exists or is proposed onsite; otherwise not expected*

<sup>(2)</sup> *A potential Pollutant if the project includes uncovered parking areas; otherwise not expected*

<sup>(3)</sup> *A potential Pollutant is land use involving animal waste*

<sup>(4)</sup> *Specifically petroleum hydrocarbons*

<sup>(5)</sup> *Specifically solvents*

<sup>(6)</sup> *Bacterial indicators are routinely detected in pavement runoff*

## E.2 Stormwater Credits

Projects that cannot implement LID BMPs but nevertheless implement smart growth principles are potentially eligible for Stormwater Credits. Utilize Table 3-8 within the WQMP Guidance Document to identify your Project Category and its associated Water Quality Credit. If not applicable, write N/A.

N/A

Table E.2 Water Quality Credits

Qualifying Project Categories	Credit Percentage <sup>2</sup>
<i>Total Credit Percentage<sup>1</sup></i>	

<sup>1</sup>Cannot Exceed 50%

<sup>2</sup>Obtain corresponding data from Table 3-8 in the WQMP Guidance Document

## E.3 Sizing Criteria

After you appropriately considered Stormwater Credits for your project, utilize Table E.3 below to appropriately size them to the DCV, or Design Flow Rate, as applicable. Please reference Chapter 3.5.2 of the WQMP Guidance Document for further information.

Table E.3 Treatment Control BMP Sizing

DMA Type/ID	DMA Area (square feet)	Post-Project Surface Type	Effective Impervious Fraction, I <sub>f</sub>	DMA Runoff Factor	DMA Area x Runoff Factor	Enter BMP Name / Identifier Here				
	[A]		[B]	[C]	[A] x [C]					
						Design Storm Depth (in)	Minimum Design Capture Volume or Design Flow Rate (cubic feet or cfs)	Total Storm Water Credit % Reduction	Proposed Volume or Flow on Plans (cubic feet or cfs)	
	$A_T = \sum[A]$				$\Sigma = [D]$	[E]	$[F] = \frac{[D] \times [E]}{[G]}$	$[F] \times (1-[H])$	[I]	

[B], [C] is obtained as described in Section 2.3.1 from the WQMP Guidance Document

[E] is for Flow-Based Treatment Control BMPs [E] = .2, for Volume-Based Control Treatment BMPs, [E] obtained from Exhibit A in the WQMP Guidance Document

[G] is for Flow-Based Treatment Control BMPs [G] = 43,560, for Volume-Based Control Treatment BMPs, [G] = 12

[H] is from the Total Credit Percentage as Calculated from Table E.2 above

[I] as obtained from a design procedure sheet from the BMP manufacturer and should be included in Appendix 6

## E.4 Treatment Control BMP Selection

Treatment Control BMPs typically provide proprietary treatment mechanisms to treat potential pollutants in runoff, but do not sustain significant biological processes. Treatment Control BMPs must have a removal efficiency of a medium or high effectiveness as quantified below:

- **High:** equal to or greater than 80% removal efficiency
- **Medium:** between 40% and 80% removal efficiency

Such removal efficiency documentation (e.g., studies, reports, etc.) as further discussed in Chapter 3.5.2 of the WQMP Guidance Document, must be included in Appendix 6. In addition, ensure that proposed Treatment Control BMPs are properly identified on the WQMP Site Plan in Appendix 1.

**Table E.4 Treatment Control BMP Selection**

Selected Treatment Control BMP Name or ID <sup>1</sup>	Priority Pollutant(s) of Concern to Mitigate <sup>2</sup>	Removal Efficiency Percentage <sup>3</sup>
ADS Barracuda Hydrodynamic Separator	Trash, TSS	100% trash, 50% TSS
Bio-Clean Modular Wetlands Units	All	See Product literature in Appendix 6

<sup>1</sup> Treatment Control BMPs must not be constructed within Receiving Waters. In addition, a proposed Treatment Control BMP may be listed more than once if they possess more than one qualifying pollutant removal efficiency.

<sup>2</sup> Cross Reference Table E.1 above to populate this column.

<sup>3</sup> As documented in a Co-Permittee Approved Study and provided in Appendix 6.

## Section F: Hydromodification

### F.1 Hydrologic Conditions of Concern (HCOC) Analysis

Once you have determined that the LID design is adequate to address water quality requirements, you will need to assess if the proposed LID Design may still create a HCOC. Review Chapters 2 and 3 (including Figure 3-7) of the WQMP Guidance Document to determine if your project must mitigate for Hydromodification impacts. If your project meets one of the following criteria which will be indicated by the check boxes below, you do not need to address Hydromodification at this time. However, if the project does not qualify for Exemptions 1, 2 or 3, then additional measures must be added to the design to comply with HCOC criteria. This is discussed in further detail below in Section F.2.

**HCOC EXEMPTION 1:** The Priority Development Project disturbs less than one acre. The Copermitttee has the discretion to require a Project-Specific WQMP to address HCOCs on projects less than one acre on a case by case basis. The disturbed area calculation should include all disturbances associated with larger common plans of development.

Does the project qualify for this HCOC Exemption?       Y     N

If Yes, HCOC criteria do not apply.

**HCOC EXEMPTION 2:** The volume and time of concentration<sup>1</sup> of storm water runoff for the post-development condition is not significantly different from the pre-development condition for a 2-year return frequency storm (a difference of 5% or less is considered insignificant) using one of the following methods to calculate:

- Riverside County Hydrology Manual
- Technical Release 55 (TR-55): Urban Hydrology for Small Watersheds (NRCS 1986), or derivatives thereof, such as the Santa Barbara Urban Hydrograph Method
- Other methods acceptable to the Co-Permittee

Does the project qualify for this HCOC Exemption?       Y     N

If Yes, report results in Table F.1 below and provide your substantiated hydrologic analysis in Appendix 7.

**Table F.1** Hydrologic Conditions of Concern Summary

	2 year – 24 hour		
	Pre-condition	Post-condition	% Difference
<b>Time of Concentration</b>			
<b>Volume (Cubic Feet)</b>			

<sup>1</sup> Time of concentration is defined as the time after the beginning of the rainfall when all portions of the drainage basin are contributing to flow at the outlet.

**HCOC EXEMPTION 3:** All downstream conveyance channels to an adequate sump (for example, Prado Dam, Lake Elsinore, Canyon Lake, Santa Ana River, or other lake, reservoir or naturally erosion resistant feature) that will receive runoff from the project are engineered and regularly maintained to ensure design flow capacity; no sensitive stream habitat areas will be adversely affected; or are not identified on the Co-Permittees Hydromodification Susceptibility Maps.

Does the project qualify for this HCOC Exemption?       Y       N

If Yes, HCOC criteria do not apply and note below which adequate sump applies to this HCOC qualifier:

## F.2 HCOC Mitigation

If none of the above HCOC Exemption Criteria are applicable, HCOC criteria is considered mitigated if they meet one of the following conditions:

- a. Additional LID BMPS are implemented onsite or offsite to mitigate potential erosion or habitat impacts as a result of HCOCs. This can be conducted by an evaluation of site-specific conditions utilizing accepted professional methodologies published by entities such as the California Stormwater Quality Association (CASQA), the Southern California Coastal Water Research Project (SCCRWP), or other Co-Permittee approved methodologies for site-specific HCOC analysis.
- b. The project is developed consistent with an approved Watershed Action Plan that addresses HCOC in Receiving Waters.
- c. Mimicking the pre-development hydrograph with the post-development hydrograph, for a 2-year return frequency storm. Generally, the hydrologic conditions of concern are not significant, if the post-development hydrograph is no more than 10% greater than pre-development hydrograph. In cases where excess volume cannot be infiltrated or captured and reused, discharge from the site must be limited to a flow rate no greater than 110% of the pre-development 2-year peak flow.

Be sure to include all pertinent documentation used in your analysis of the items a, b or c in Appendix 7.

The project is located within the Riverside County WAP mapping tool as approved April 20, 2017.

## Section G: Source Control BMPs

Source control BMPs include permanent, structural features that may be required in your project plans — such as roofs over and berms around trash and recycling areas — and Operational BMPs, such as regular sweeping and “housekeeping”, that must be implemented by the site’s occupant or user. The MEP standard typically requires both types of BMPs. In general, Operational BMPs cannot be substituted for a feasible and effective permanent BMP. Using the Pollutant Sources/Source Control Checklist in Appendix 8, review the following procedure to specify Source Control BMPs for your site:

1. **Identify Pollutant Sources:** Review Column 1 in the Pollutant Sources/Source Control Checklist. Check off the potential sources of Pollutants that apply to your site.
2. **Note Locations on Project-Specific WQMP Exhibit:** Note the corresponding requirements listed in Column 2 of the Pollutant Sources/Source Control Checklist. Show the location of each Pollutant source and each permanent Source Control BMP in your Project-Specific WQMP Exhibit located in Appendix 1.
3. **Prepare a Table and Narrative:** Check off the corresponding requirements listed in Column 3 in the Pollutant Sources/Source Control Checklist. In the left column of Table G.1 below, list each potential source of runoff Pollutants on your site (from those that you checked in the Pollutant Sources/Source Control Checklist). In the middle column, list the corresponding permanent, Structural Source Control BMPs (from Columns 2 and 3 of the Pollutant Sources/Source Control Checklist) used to prevent Pollutants from entering runoff. **Add additional narrative** in this column that explains any special features, materials or methods of construction that will be used to implement these permanent, Structural Source Control BMPs.
4. **Identify Operational Source Control BMPs:** To complete your table, refer once again to the Pollutant Sources/Source Control Checklist. List in the right column of your table the Operational BMPs that should be implemented as long as the anticipated activities continue at the site. Copermittee stormwater ordinances require that applicable Source Control BMPs be implemented; the same BMPs may also be required as a condition of a use permit or other revocable Discretionary Approval for use of the site.

**Table G.1** Permanent and Operational Source Control Measures

Potential Sources of Runoff pollutants	Permanent Structural Source Control BMPs	Operational Source Control BMPs
On-site storm drain inlets	Mark all inlets with the words “Only Rain Down the Storm Drain” or similar. Catch Basin Markers may be available from the Riverside County Flood Control and Water Conservation District, call 951.955.1200 to verify.	<ul style="list-style-type: none"> <li>• Maintain and periodically repaint or replace inlet markings.</li> <li>• Provide stormwater pollution prevention information to new site owners, lessees, or operators.</li> <li>• See applicable operational BMPs in Fact Sheet SC-44, “Drainage System Maintenance,” in the CASQA</li> </ul>

		<p>Maintenance,” in the CASQA Stormwater Quality Handbooks at <a href="http://www.cabmphandbooks.com">www.cabmphandbooks.com</a></p> <p>Include the following in lease agreements: “Tenant shall not allow anyone to discharge anything to storm drains or to store or deposit materials so as to create a potential discharge to storm drains.”</p>
Landscape/ Outdoor Pesticide Use	<ul style="list-style-type: none"> <li>• Preserve existing native trees, shrubs, and ground cover to the maximum extent possible.</li> <li>• Design landscaping to minimize irrigation and runoff, to promote surface infiltration where appropriate, and to minimize the use of fertilizers and pesticides that can contribute to stormwater pollution.</li> <li>• Where landscaped areas are used to retain or detain stormwater, specify plants that are tolerant of saturated soil conditions.</li> <li>• Consider using pest-resistant plants, especially adjacent to hardscape.</li> </ul> <p>To insure successful establishment, select plants appropriate to site soils, slopes, climate, sun, wind, rain, land use, air movement, ecological consistency, and plant interactions.</p>	<ul style="list-style-type: none"> <li>• Maintain landscaping using minimum or no pesticides.</li> <li>• See applicable operational maintenance practices in the provided Educational Material</li> </ul> <p>Provide IPM information to new owners, lessees and operators.</p>
Refuse areas	<ul style="list-style-type: none"> <li>• State how site refuse will be handled and provide supporting detail to what is shown on plans.</li> </ul> <p>State that signs will be posted on or near dumpsters with the</p>	<p>Provide adequate number of receptacles. Inspect receptacles regularly; repair or replace leaky receptacles. Keep receptacles covered. Prohibit/prevent dumping of liquid or hazardous wastes. Post “no hazardous</p>

		clean up spills immediately. Keep spill control materials available on-site. See Fact Sheet SC-34, "Waste Handling and Disposal" in the CASQA Stormwater Quality Handbooks at <a href="http://www.cabmphandbooks.com">www.cabmphandbooks.com</a>
Loading Docks	Install door skirts (cowling) at each bay that enclose the end of the trailer.	<ul style="list-style-type: none"> <li>• Move loaded and unloaded items indoors as soon as possible.</li> </ul> <p>See Fact Sheet SC-30, "Outdoor Loading and Unloading," in the CASQA Stormwater Quality Handbooks at <a href="http://www.cabmphandbooks.com">www.cabmphandbooks.com</a></p>
Plazas, sidewalks, and parking lots.		Sweep plazas, sidewalks, and parking lots regularly to prevent accumulation of litter and debris. Collect debris from pressure washing to prevent entry into the storm drain system. Collect washwater containing any cleaning agent or degreaser and discharge to the sanitary sewer not to a storm drain.
Interior Floor Drains	Interior Floor Drains shall be plumbed to Sanitary Sewer system.	Inspect and maintain drains to be free of blockage and overflow
Food Service	Outdoor Dining may occur fast food restaurants depending on final site plan at	<ul style="list-style-type: none"> <li>• See "The Food Service Industry Best Management Practices for: Restaurants, Grocery Stores, Delicatessens and Bakeries" brochure.</li> </ul>
Car Wash Areas	Commercial car wash facilities shall be designed such that no runoff from the facility is discharged to the storm drain system. Wastewater from the facility shall discharge to the sanitary sewer, or a wastewater reclamation system	<ul style="list-style-type: none"> <li>• Washwater from vehicle and equipment washing operations shall not be discharged to the storm drain system. Refer to "Outdoor Cleaning Activities and Professional Mobile Service Providers" for many of the Potential Sources of Runoff Pollutants.</li> </ul>

		<ul style="list-style-type: none"> <li>•</li> </ul>
Fuel Dispensing Areas	<p>Fueling areas shall have impermeable pavement (i.e., portland cement concrete or equivalent smooth impervious surface) that are: a) graded at the minimum slope necessary to prevent ponding; and b) separated from the rest of the site by a grade break that prevents run-on of stormwater to the maximum extent practicable.</p> <p>Fueling areas shall be covered by a canopy that extends a minimum of ten feet in each direction from each pump. [Alternative: The fueling area must be covered and the cover's minimum dimensions must be equal to or greater than the area within the grade break or fuel dispensing area1.] The canopy [or cover] shall not drain onto the fueling area.</p>	<p>The property owner shall dry sweep the fueling area routinely.</p> <ul style="list-style-type: none"> <li>• See the Fact Sheet SD-30, "Fueling Areas" in the CASQA Stormwater Quality Handbooks at <a href="http://www.cabmphandbooks.com">www.cabmphandbooks.com</a></li> </ul>
Fire Sprinkler Test Water	<p>Provide a means to drain fire sprinkler test water to the sanitary sewer.</p>	<p>See the note in Fact Sheet SC-41, "Building and Grounds Maintenance," in the CASQA Stormwater Quality Handbooks at <a href="http://www.cabmphandbooks.com">www.cabmphandbooks.com</a></p>

## Section H: Construction Plan Checklist

Populate Table H.1 below to assist the plan checker in an expeditious review of your project. The first two columns will contain information that was prepared in previous steps, while the last column will be populated with the corresponding plan sheets. This table is to be completed with the submittal of your final Project-Specific WQMP.

**Table H.1 Construction Plan Cross-reference**

BMP No. or ID	BMP Identifier and Description	Corresponding Plan Sheet(s)	BMP Location (Lat/Long)
UG-A / MW-A	U/G STORAGE & MOD. WETLANDS	Concept Grading 4 of 7	33-50-38.67 / 117-14-41.56
LMW-B	LINEAR MODULAR WETLANDS	Grading Plan 4 of 7	33-50-38.36 / 117-14-42.14
LMW-C	LINEAR MODULAR WETLANDS	Grading Plan 4 of 7	33-50-39.34 / 117-14-43.62
LMW-D	LINEAR MODULAR WETLANDS	Grading Plan 4 of 7	33-50-39.34 / 117-14-45.39
LMW-E	LINEAR MODULAR WETLANDS	Grading Plan 4 of 7	33-50-39.35 / 117-14-46.42
LMW-F	LINEAR MODULAR WETLANDS	Grading Plan 4 of 7	33-50-39.36 / 117-14-48.04
LMW-G	LINEAR MODULAR WETLANDS	Grading Plan 4 of 7	33-50-38.77 / 117-14-49.56
LMW-H	LINEAR MODULAR WETLANDS	Grading Plan 4 of 7	33-50-39.06 / 117-14-51.52
UG-I / MW-I	U/G STORAGE & MOD. WETLANDS	Grading Plan 5 of 7	33-50-37.76 / 117-14-41.99
UG-J / MW-J	U/G STORAGE & MOD. WETLANDS	Grading Plan 5 of 7	33-50-35.24 / 117-14-52.01
UG-K / MW-K	U/G STORAGE & MOD. WETLANDS	Grading Plan 5 of 7	33-50-35.28 / 117-14-38.75
LMW-L	LINEAR MODULAR WETLANDS	Grading Plan 4 of 7	33-50-37.32 / 117-114-38.63

Note that the updated table — or Construction Plan WQMP Checklist — is **only a reference tool** to facilitate an easy comparison of the construction plans to your Project-Specific WQMP. Co-Permittee staff can advise you regarding the process required to propose changes to the approved Project-Specific WQMP.

## Section I: Operation, Maintenance and Funding

The Copermittee will periodically verify that Stormwater BMPs on your site are maintained and continue to operate as designed. To make this possible, your Copermittee will require that you include in Appendix 9 of this Project-Specific WQMP:

1. A means to finance and implement facility maintenance in perpetuity, including replacement cost.
2. Acceptance of responsibility for maintenance from the time the BMPs are constructed until responsibility for operation and maintenance is legally transferred. A warranty covering a period following construction may also be required.
3. An outline of general maintenance requirements for the Stormwater BMPs you have selected.
4. Figures delineating and designating pervious and impervious areas, location, and type of Stormwater BMP, and tables of pervious and impervious areas served by each facility. Geo-locating the BMPs using a coordinate system of latitude and longitude is recommended to help facilitate a future statewide database system.
5. A separate list and location of self-retaining areas or areas addressed by LID Principles that do not require specialized O&M or inspections but will require typical landscape maintenance as noted in Chapter 5, pages 85-86, in the WQMP Guidance. Include a brief description of typical landscape maintenance for these areas.

Your local Co-Permittee will also require that you prepare and submit a detailed Stormwater BMP Operation and Maintenance Plan that sets forth a maintenance schedule for each of the Stormwater BMPs built on your site. An agreement assigning responsibility for maintenance and providing for inspections and certification may also be required.

Details of these requirements and instructions for preparing a Stormwater BMP Operation and Maintenance Plan are in Chapter 5 of the WQMP Guidance Document.

**Maintenance Mechanism:** Perris Landco, LLC  
201 Spear Street  
Suite 1100  
San Francisco, CA  
312-576-4291  
Stanley Zheng

Will the proposed BMPs be maintained by a Home Owners' Association (HOA) or Property Owners Association (POA)?

Y       N

Include your Operation and Maintenance Plan and Maintenance Mechanism in Appendix 9. Additionally, include all pertinent forms of educational materials for those personnel that will be maintaining the proposed BMPs within this Project-Specific WQMP in Appendix 10.

# Appendix 1: Maps and Site Plans

*Location Map, WQMP Site Plan and Receiving Waters Map*

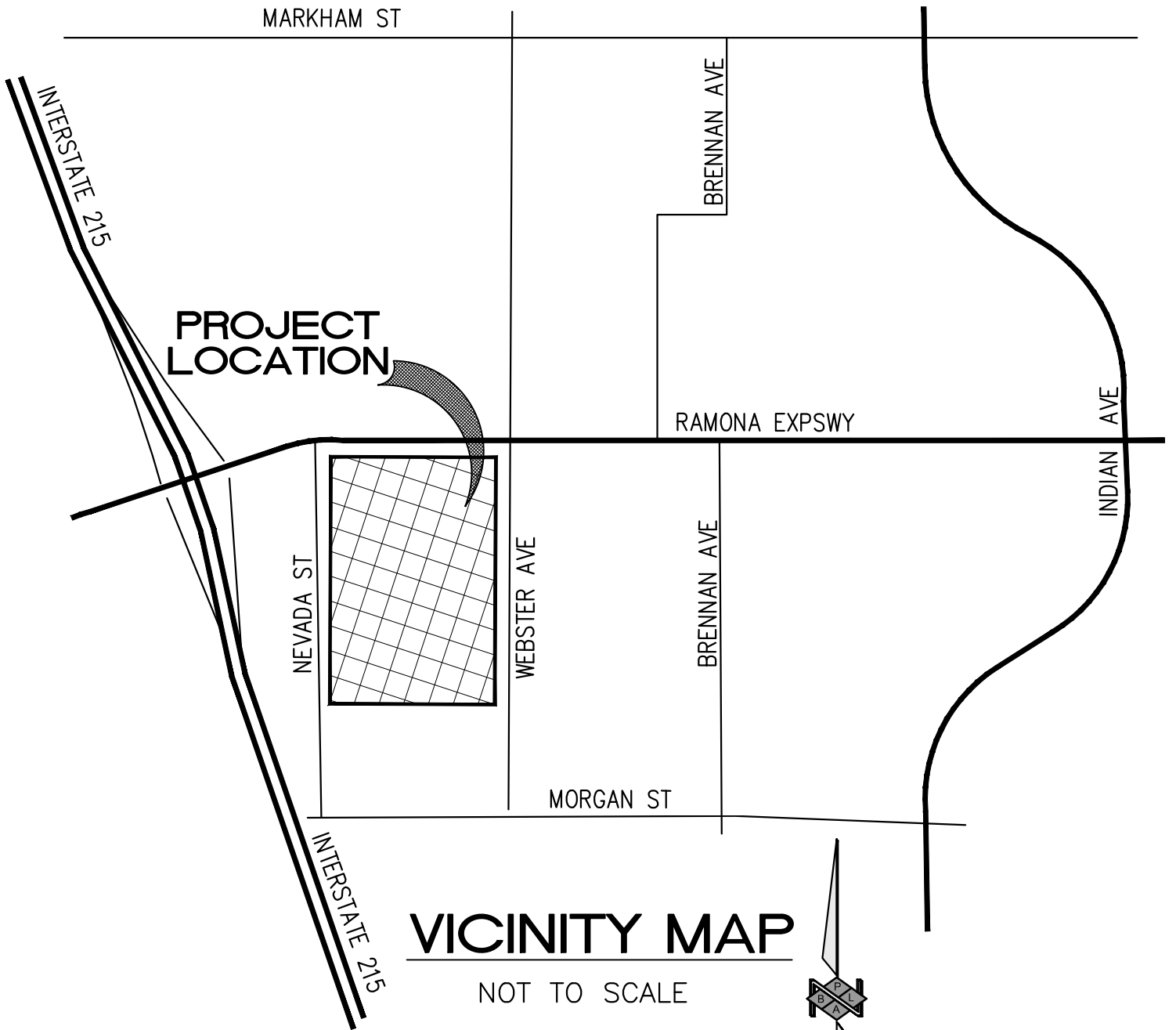

# VICINITY MAP

NOT TO SCALE

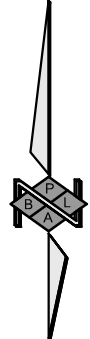

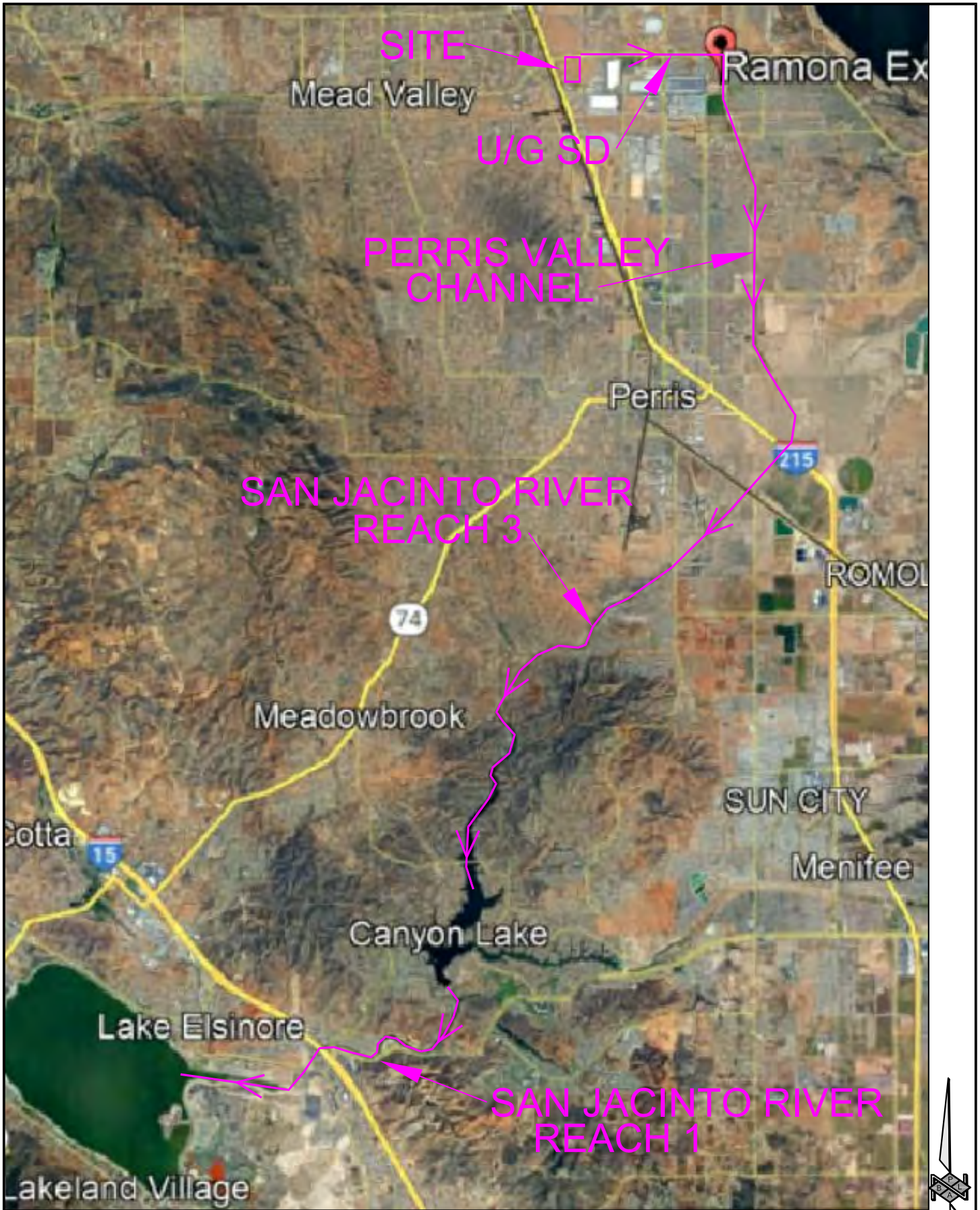

RECEIVING WATERS MAP

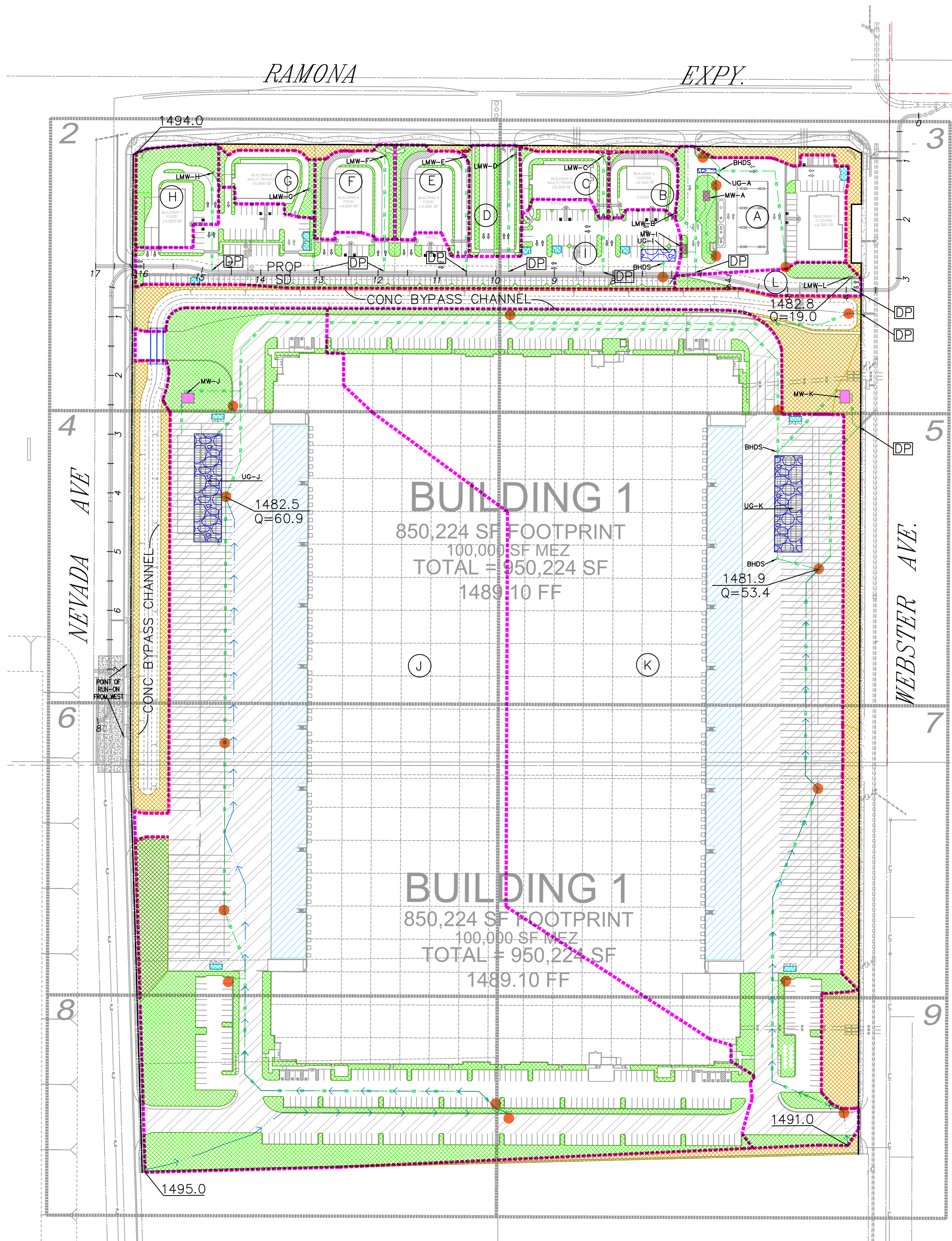

DMA "A" DATA	DMA "B" DATA	DMA "C" DATA	DMA "D" DATA
RETAIL BLD 1 - FUEL/CONVENIENCE	RETAIL BLD 2 - DRIVE THRU	RETAIL BLD 3 - DRIVE THRU	COMMON AREA / DRIVE AISLES
TOTAL AREA TRIBUTARY TO TREATMENT = 54,514 SF (1.25 AC)	TOTAL AREA TRIBUTARY TO TREATMENT = 11,827 SF (0.27 AC)	TOTAL AREA TRIBUTARY TO TREATMENT = 13,893 SF (0.31 AC)	TOTAL AREA TRIBUTARY TO TREATMENT = 16,879 SF (0.39 AC)
ROOF & CANOPY AREA: 11,579 SF PAVED AREA: 34,800 SF ONSITE LANDSCAPE: 8,135 SF	ROOF AREA: 2,400 SF PAVED AREA: 8,359 SF ONSITE LANDSCAPE: 1,068 SF	ROOF AREA: 6,000 SF PAVED AREA: 5,778 SF ONSITE LANDSCAPE: 1,915 SF	ROOF AREA: 0 SF PAVED AREA: 11,897 SF ONSITE LANDSCAPE: 5,182 SF
0.83 IMPERVIOUS RATIO	0.91 IMPERVIOUS RATIO	0.86 IMPERVIOUS RATIO	0.69 IMPERVIOUS RATIO
DESIGN CAPTURE VOLUME: = 2,043 CF	DESIGN Q <sub>bmp</sub> : = 0.1 CFS	DESIGN Q <sub>bmp</sub> : = 0.1 CFS	DESIGN Q <sub>bmp</sub> : = 0.1 CFS
DMA "E" DATA	DMA "F" DATA	DMA "G" DATA	DMA "H" DATA
RETAIL BLD 4 - DRIVE THRU	RETAIL BLD 5 - DRIVE THRU	RETAIL BLD 6 - DRIVE THRU	RETAIL BLD 7 - DRIVE THRU
TOTAL AREA TRIBUTARY TO TREATMENT = 18,659 SF (0.43 AC)	TOTAL AREA TRIBUTARY TO TREATMENT = 19,674 SF (0.45 AC)	TOTAL AREA TRIBUTARY TO TREATMENT = 14,875 SF (0.34 AC)	TOTAL AREA TRIBUTARY TO TREATMENT = 22,484 SF (0.52 AC)
ROOF AREA: 4,500 SF PAVED AREA: 11,540 SF ONSITE LANDSCAPE: 2,619 SF	ROOF AREA: 4,500 SF PAVED AREA: 11,607 SF ONSITE LANDSCAPE: 3,567 SF	ROOF AREA: 5,500 SF PAVED AREA: 6,085 SF ONSITE LANDSCAPE: 3,290 SF	ROOF AREA: 4,500 SF PAVED AREA: 8,904 SF ONSITE LANDSCAPE: 9,080 SF
0.86 IMPERVIOUS RATIO	0.81 IMPERVIOUS RATIO	0.78 IMPERVIOUS RATIO	0.60 IMPERVIOUS RATIO
DESIGN Q <sub>bmp</sub> : = 0.1 CFS	DESIGN Q <sub>bmp</sub> : = 0.1 CFS	DESIGN Q <sub>bmp</sub> : = 0.1 CFS	DESIGN Q <sub>bmp</sub> : = 0.1 CFS
DMA "I" DATA	DMA "J" DATA	DMA "K" DATA	DMA "L" DATA
COMMON AREA / PARKING / DRIVE AISLES	INDUSTRIAL BLD 1 - WEST SIDE	INDUSTRIAL BLD 1 - EAST SIDE	INDUSTRIAL BLD 1 - EAST SIDE
TOTAL AREA TRIBUTARY TO TREATMENT = 97,543 SF (2.24 AC)	TOTAL AREA TRIBUTARY TO TREATMENT = 905,010 SF (20.78 AC)	TOTAL AREA TRIBUTARY TO TREATMENT = 766,867 SF (17.60 AC)	TOTAL AREA TRIBUTARY TO TREATMENT = 12,667 SF (0.29 AC)
ROOF AREA: 0 SF PAVED AREA: 88,577 SF ONSITE LANDSCAPE: 8,966 SF	ROOF AREA: 438,446 SF PAVED AREA: 365,944 SF ONSITE LANDSCAPE: 101,182 SF	ROOF AREA: 419,494 SF PAVED AREA: 306,547 SF ONSITE LANDSCAPE: 40,615 SF	ROOF AREA: 0 SF PAVED AREA: 8,441 SF ONSITE LANDSCAPE: 4,226 SF
0.91 IMPERVIOUS RATIO	0.89 IMPERVIOUS RATIO	0.95 IMPERVIOUS RATIO	0.67 IMPERVIOUS RATIO
DESIGN CAPTURE VOLUME: = 3,867 CF	DESIGN CAPTURE VOLUME: = 35,220 CF	DESIGN CAPTURE VOLUME: = 31,519 CF	DESIGN Q <sub>bmp</sub> : = 0.1 CFS
<b>DMA "E" DATA</b> TOTAL AREA NOT TRIBUTARY TO TREATMENT = 126,129 SF (2.90 AC)			

**PROJECT DATA:**

TOTAL NET AREA OF PROPOSED DEVELOPMENT: 2,141,645 Sq Ft (49.17 Ac)

TOTAL DISTURBED AREA: 2,141,645 Sq Ft (49.17 Ac)

CURRENT USE: VACANT WITH RUN-ON FROM RCFC FACILITY WEST OF NEVADA

PROPOSED USE: INDUSTRIAL

WATERSHED: RAMONA EXPRESSWAY STORM DRAIN/PERRIS VALLEY CHANNEL

SUB-WATERSHED: CANYON LAKE/LAKE ELSINORE

- NON-STRUCTURAL BMPs**
- PROPERTY OWNER EDUCATION
  - ACTIVITY RESTRICTIONS
  - COMMON AREA LANDSCAPE MAINTENANCE
  - BMP MAINTENANCE
  - LOCAL INDUSTRIAL PERMIT COMPLIANCE
  - SPILL CONTINGENCY PLAN
  - UNIFORM FIRE CODE IMPLEMENTATION
  - COMMON AREA LITTER CONTROL
  - EMPLOYEE TRAINING
  - ACTIVITY RESTRICTIONS
  - HOUSEKEEPING OF LOADING DOCKS
  - COMMON AREA CATCH BASIN INSPECTION
  - PARKING LOT SWEEPING

**LEGEND STRUCTURAL / TREATMENT BMPs**

- LANDSCAPE AREA EFFICIENT IRRIGATION
- LANDSCAPE AREA RUNOFF-MINIMIZING DESIGN
- SELF-TREATING LANDSCAPE AREAS NOT TRIBUTARY TO TREATMENT (DMA E)
- COVERED TRASH ENCLOSURE
- DOCK AREAS
- TRAILER AREAS
- CATCH BASIN STENCIL
- FLOW PATTERN
- DMA BOUNDARY
- ONSITE STORM DRAIN
- MODULAR WETLANDS UNIT
- UNDERGROUND STORAGE ARRAY STORMTECH CHAMBERS (OR EQUAL)
- DMA DESIGNATION
- MW- MODULAR WETLANDS UNIT
- LMW- LINEAR MODULAR WETLANDS UNIT
- BHDS- BARRACUDA HYDRODYNAMIC SEPARATOR (OR EQUAL)
- DISCHARGE POINT TO PUBLIC SD

40 SCALE  
DETAIL SHT

NOTE: ALL CATCH BASIN INLETS SHALL BE STENCILED WITH "NO DUMPING-DRAINS TO RIVER"

STENCIL  
N.T.S.

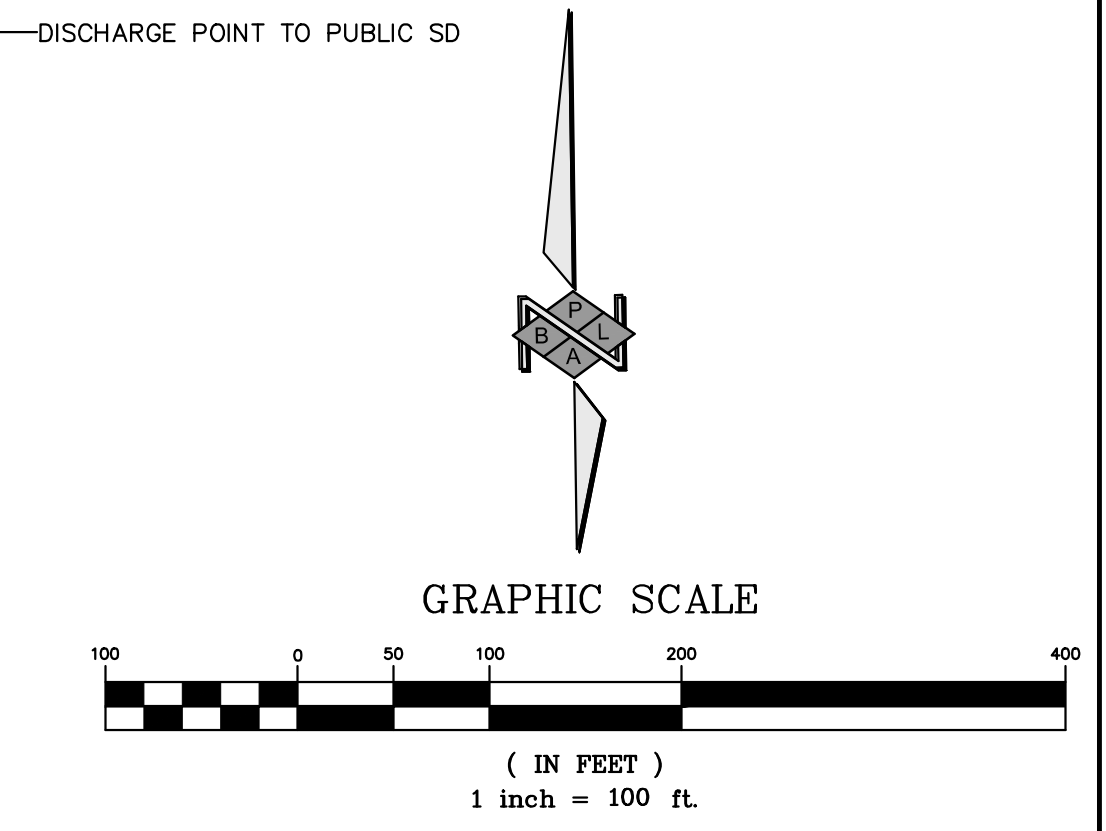

Sep 19 2022

PREPARED BY:	REVISIONS:								
<b>PBLA ENGINEERING, INC.</b> Planning • Engineering • Surveying 1809 E. DYER ROAD, STE 301 SANTA ANA, CA 92705 (888) 714-9642 • (714) 389-9191 FAX	<table border="1"> <tr><td> </td><td> </td></tr> <tr><td> </td><td> </td></tr> <tr><td> </td><td> </td></tr> <tr><td> </td><td> </td></tr> </table>								

**PRELIMINARY POST CONSTRUCTION MASTER BMP SITE PLAN**  
**RAMONA GATEWAY COMMERCE CENTER**  
 P21-00013 - PERRIS, CA

JOB NO.  
139-1  
SHEET  
1 of 1

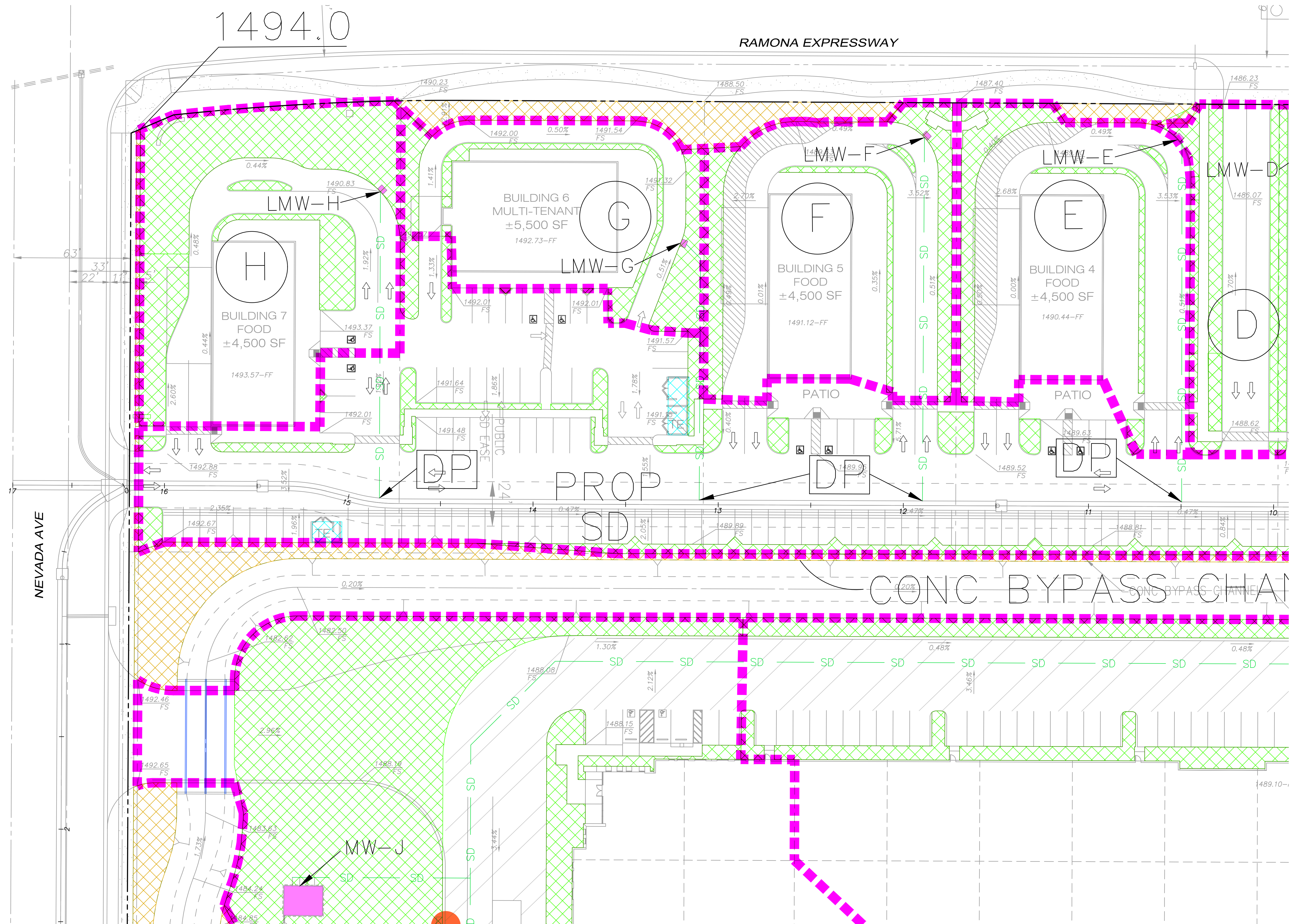

- LEGEND  
STRUCTURAL / TREATMENT BMPs
- DMA BOUNDARY
  - SD — ONSITE STORM DRAIN
  - LANDSCAPE AREA EFFICIENT IRRIGATION  
LANDSCAPE AREA RUNOFF-MINIMIZING DESIGN
  - SELF-TREATING LANDSCAPE AREAS  
NOT TRIBUTARY TO TREATMENT (DMA E)
  - COVERED TRASH ENCLOSURE
  - DOCK AREAS
  - TRAILER AREAS
  - CATCH BASIN STENCIL
  - FLOW PATTERN
  - MODULAR WETLANDS UNIT
  - UNDERGROUND STORAGE ARRAY  
STORMTECH CHAMBERS (OR EQUAL)
  - DMA DESIGNATION
  - MW- MODULAR WETLANDS UNIT
  - LMW- LINEAR MODULAR WETLANDS UNIT
  - BHDS — BARRACUDA HYDRODYNAMIC SEPARATOR (OR EQUAL)
  - DP — DISCHARGE POINT TO PUBLIC SD

RAMONA EXPSWY

2	3
4	5
6	7
8	9

INDEX MAP  
N.T.S.

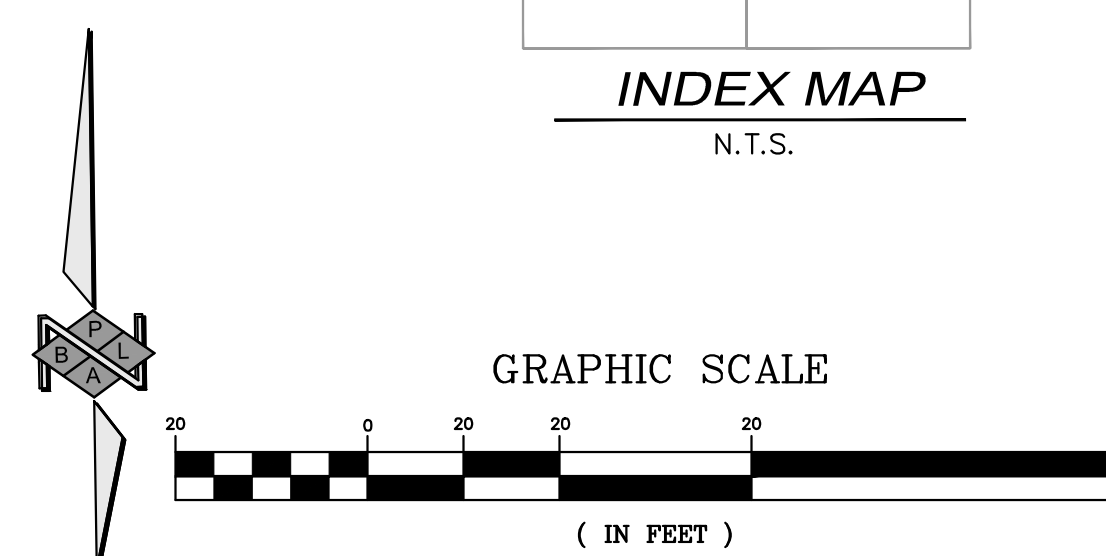

Sep 15 2022

	<b>PREPARED BY:</b> <b>PBL ENGINEERING, INC.</b> Planning • Engineering • Surveying 1809 E. DYER ROAD, STE 301 SANTA ANA, CA 92705 (888) 714-9642 • (714) 389-9191 FAX	<b>REVISIONS:</b>	<b>PRELIMINARY POST CONSTRUCTION MASTER BMP SITE PLAN RAMONA GATEWAY COMMERCE CENTER P21-00013 - PERRIS, CA</b>	<b>JOB NO.</b> 139-1 <b>SHEET</b> 2 of 1

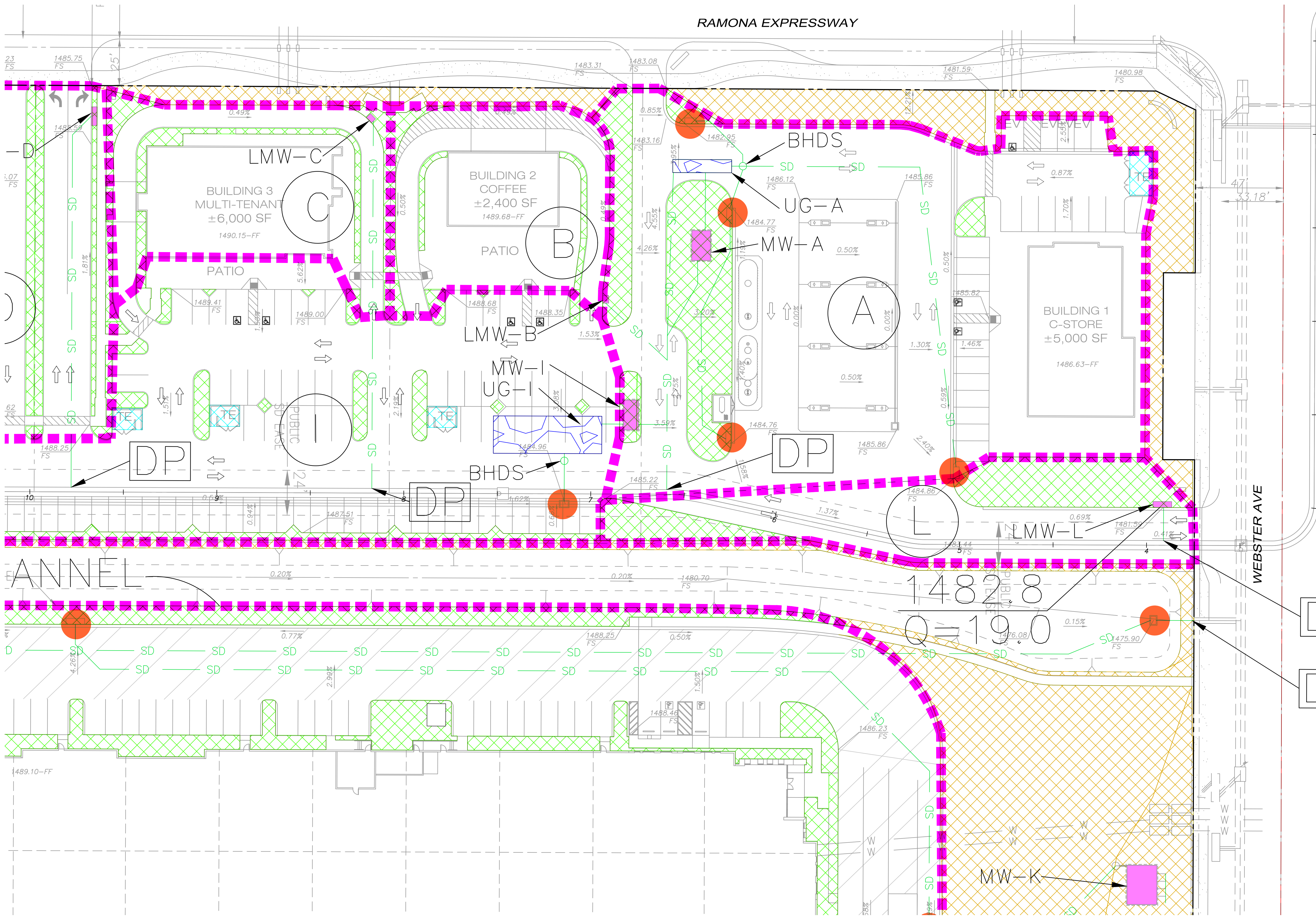

- LEGEND
- STRUCTURAL / TREATMENT BMPs
- DMA BOUNDARY
  - ON-SITE STORM DRAIN
  - LANDSCAPE AREA EFFICIENT IRRIGATION
  - LANDSCAPE AREA RUNOFF-MINIMIZING DESIGN
  - SELF-TREATING LANDSCAPE AREAS NOT TRIBUTARY TO TREATMENT (DMA E)
  - COVERED TRASH ENCLOSURE
  - DOCK AREAS
  - TRAILER AREAS
  - CATCH BASIN STENCIL
  - FLOW PATTERN
  - MODULAR WETLANDS UNIT
  - UNDERGROUND STORAGE ARRAY STORMTECH CHAMBERS (OR EQUAL)
  - DMA DESIGNATION
  - MODULAR WETLANDS UNIT
  - LINEAR MODULAR WETLANDS UNIT
  - BARRACUDA HYDRODYNAMIC SEPARATOR (OR EQUAL)
  - DISCHARGE POINT TO PUBLIC SD

SEE SHEET 2

SEE SHEET 5

RAMONA EXPSWY

2	3
4	5
6	7
8	9

NEVADA AVE WEBSTER AVE

INDEX MAP  
N.T.S.

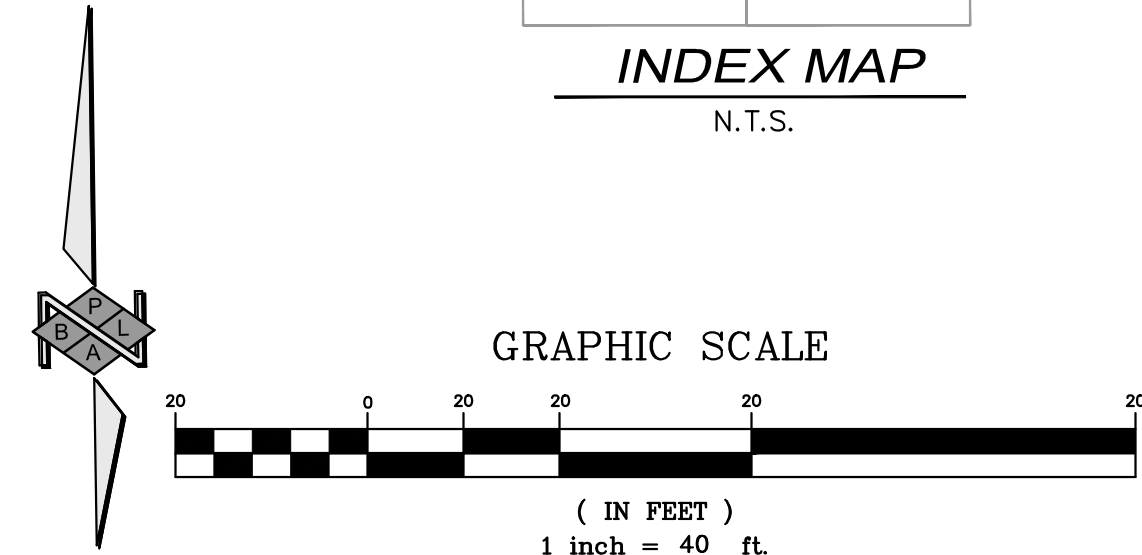

Sep 15 2022

<p>PREPARED BY: <b>PBLA ENGINEERING, INC.</b> Planning • Engineering • Surveying 1809 E. DYER ROAD, STE 301 SANTA ANA, CA 92705 (888) 714-9642 • (714) 389-9191 FAX</p>	<p>REVISIONS:</p>

**PRELIMINARY POST CONSTRUCTION  
MASTER BMP SITE PLAN  
RAMONA GATEWAY COMMERCE CENTER  
P21-0013 - PERRIS, CA**

JOB NO.  
139-1  
SHEET  
3 of 10

SEE SHEET 2

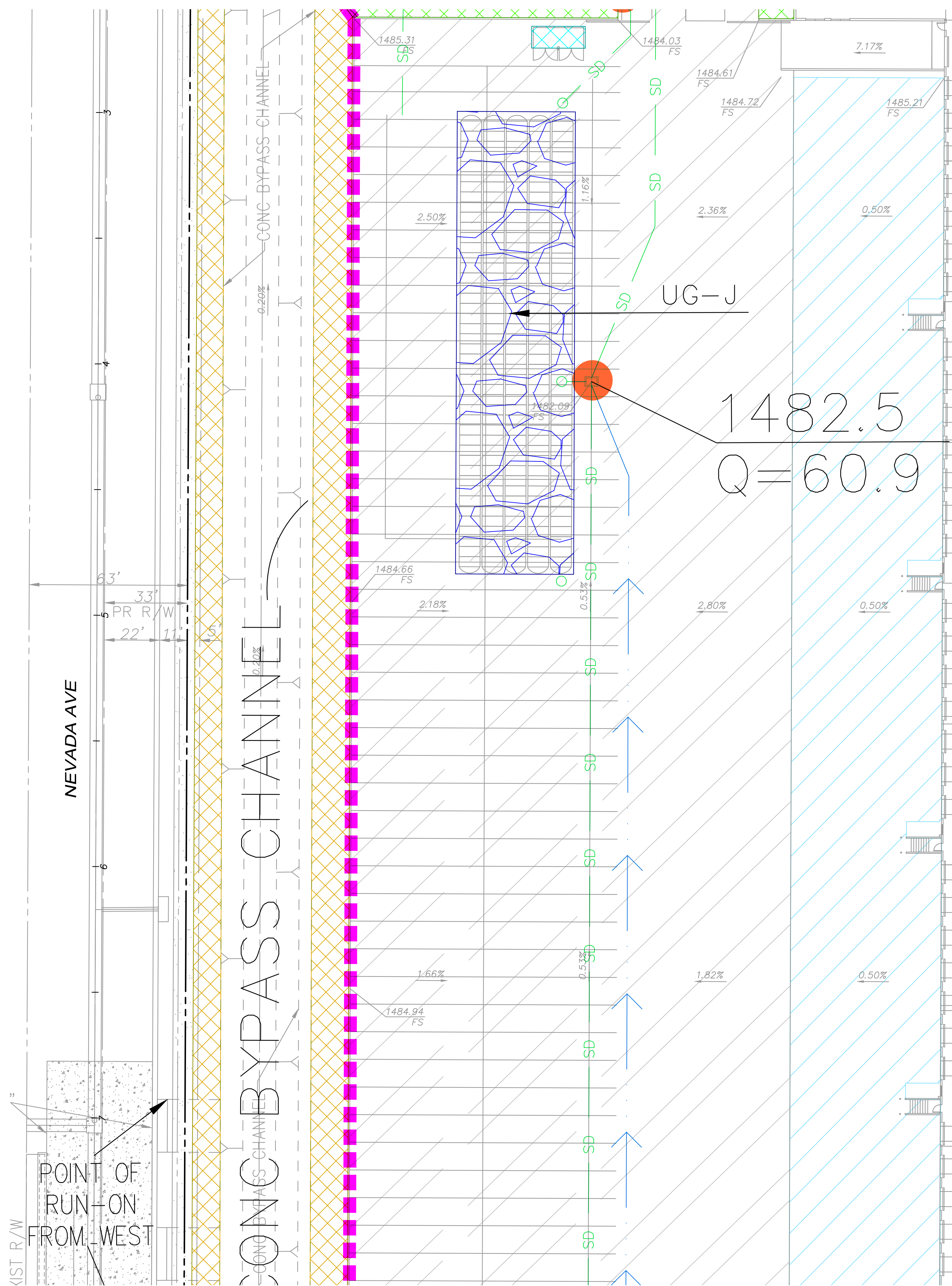

**BUILD**  
 850,224 SF  
 100,000  
 TOTAL =  
 1489

SEE SHEET 5

- LEGEND  
 STRUCTURAL / TREATMENT BMPs
- DMA BOUNDARY
  - SD — ONSITE STORM DRAIN
  - LANDSCAPE AREA EFFICIENT IRRIGATION
  - LANDSCAPE AREA RUNOFF-MINIMIZING DESIGN
  - SELF-TREATING LANDSCAPE AREAS NOT TRIBUTARY TO TREATMENT (DMA E)
  - COVERED TRASH ENCLOSURE
  - DOCK AREAS
  - TRAILER AREAS
  - CATCH BASIN STENCIL
  - FLOW PATTERN
  - MODULAR WETLANDS UNIT
  - UNDERGROUND STORAGE ARRAY STORMTECH CHAMBERS (OR EQUAL)
  - DMA DESIGNATION
  - MW- — MODULAR WETLANDS UNIT
  - LMW- — LINEAR MODULAR WETLANDS UNIT
  - BHDS — BARRACUDA HYDRODYNAMIC SEPARATOR (OR EQUAL)
  - DP — DISCHARGE POINT TO PUBLIC SD

J

RAMONA EXPSWY

2	3
4	5
6	7
8	9

INDEX MAP  
N.T.S.

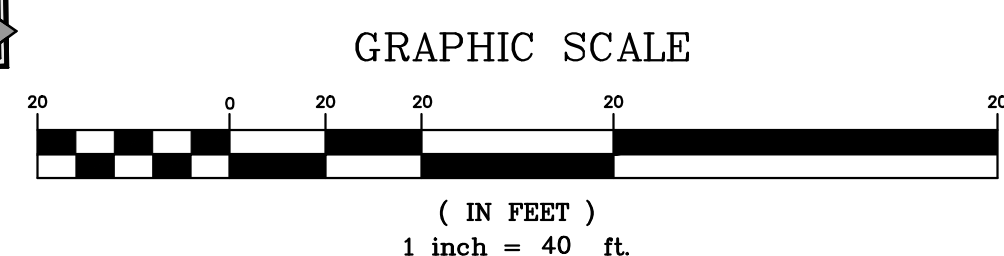
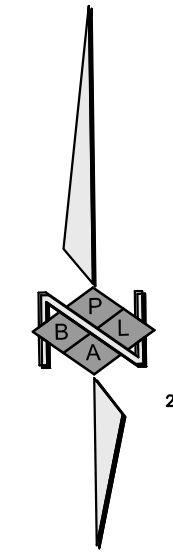

SEE SHEET 6

Sep 15 2022

	PREPARED BY:	PBLA ENGINEERING, INC. Planning • Engineering • Surveying 1809 E. DYER ROAD, STE 301 SANTA ANA, CA 92705 (888) 714-9642 • (714) 389-9191 FAX
	REVISIONS:	

**PRELIMINARY POST CONSTRUCTION  
 MASTER BMP SITE PLAN  
 RAMONA GATEWAY COMMERCE CENTER  
 P21-00013 - PERRIS, CA**

JOB NO.  
 139-1  
 SHEET  
 4 of 1

NEVADA AVE

CONC BYPASS CHANNEL

POINT OF RUN-ON FROM WEST

1ST R/W

63' PR R/W

33'

22'

1'

5'

CONC BYPASS CHANNEL

0.20%

0.10%

0.10%

0.10%

1485.31 FS

1484.03 FS

1484.61 FS

1484.72 FS

1485.21 FS

2.50%

2.36%

0.50%

7.17%

2.18%

2.80%

0.50%

1.66%

1.82%

0.50%

1484.66 FS

1484.94 FS

1482.09 FS

UG-J

1482.5  
Q=60.9

SEE SHEET 3

**BUILDING 1**  
**FF FOOTPRINT**  
**00 SF MEZ**  
**= 950,224 SF**  
**39.10 FF**

SEE SHEET 4

K

SEE SHEET 7

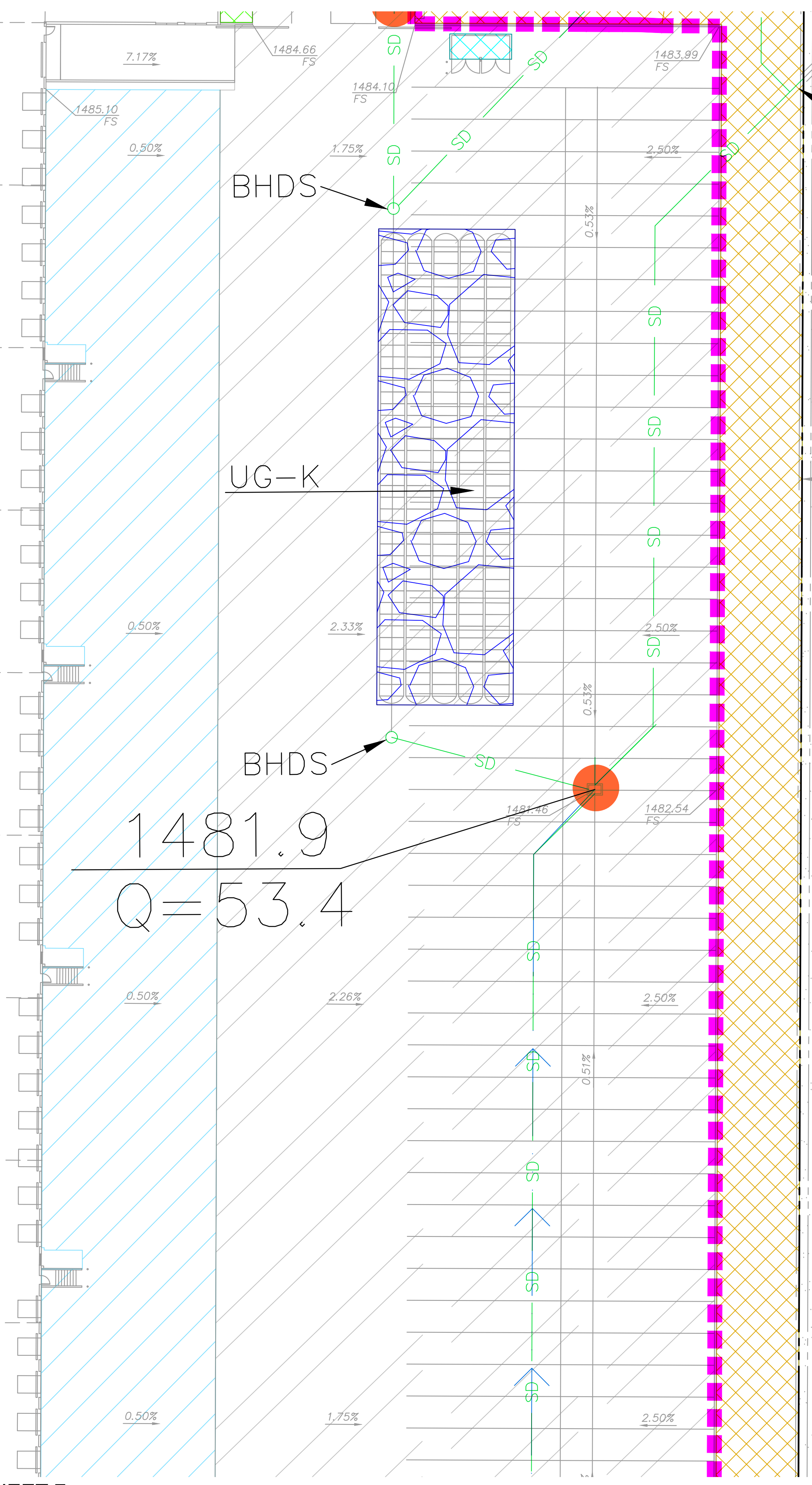

- LEGEND  
 STRUCTURAL / TREATMENT BMPs
- DMA BOUNDARY
  - SD — ONSITE STORM DRAIN
  - LANDSCAPE AREA EFFICIENT IRRIGATION
  - LANDSCAPE AREA RUNOFF-MINIMIZING DESIGN
  - SELF TREATING LANDSCAPE AREAS NOT TRIBUTARY TO TREATMENT (DMA E)
  - COVERED TRASH ENCLOSURE
  - DOCK AREAS
  - TRAILER AREAS
  - CATCH BASIN STENCIL
  - FLOW PATTERN
  - MODULAR WETLANDS UNIT
  - UNDERGROUND STORAGE ARRAY STORMTECH CHAMBERS (OR EQUAL)
  - ⊙ — DMA DESIGNATION
  - MW — MODULAR WETLANDS UNIT
  - LMW — LINEAR MODULAR WETLANDS UNIT
  - BHDS — BARRACUDA HYDRODYNAMIC SEPARATOR (OR EQUAL)
  - DP — DISCHARGE POINT TO PUBLIC SD

DP

47' PRI R/W  
 32'

VAC

WEBSTER AVE

RAMONA EXPSWY

2	3
4	5
6	7
8	9

INDEX MAP  
 N.T.S.

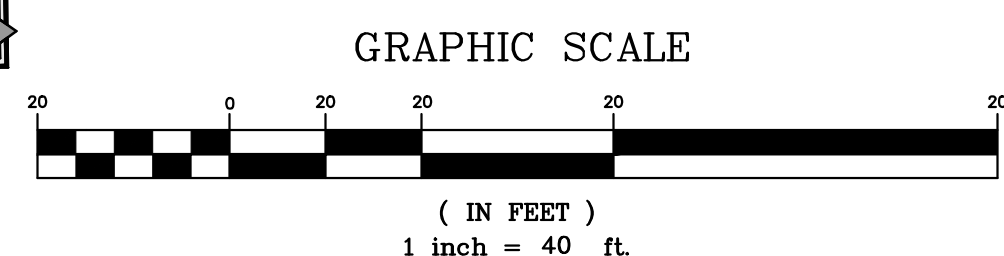
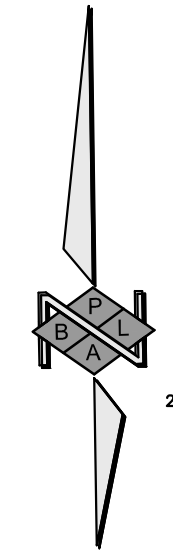

Sep 15 2022

PREPARED BY:  
**PBLA ENGINEERING, INC.**  
 Planning • Engineering • Surveying  
 1809 E. DYER ROAD, STE 301  
 SANTA ANA, CA 92705  
 (888) 714-9642 • (714) 389-9191 FAX

REVISIONS:

**PRELIMINARY POST CONSTRUCTION  
 MASTER BMP SITE PLAN  
 RAMONA GATEWAY COMMERCE CENTER  
 P21-00013 - PERRIS, CA**

JOB NO.  
 139-1  
 SHEET  
 5 of 10

SEE SHEET 4

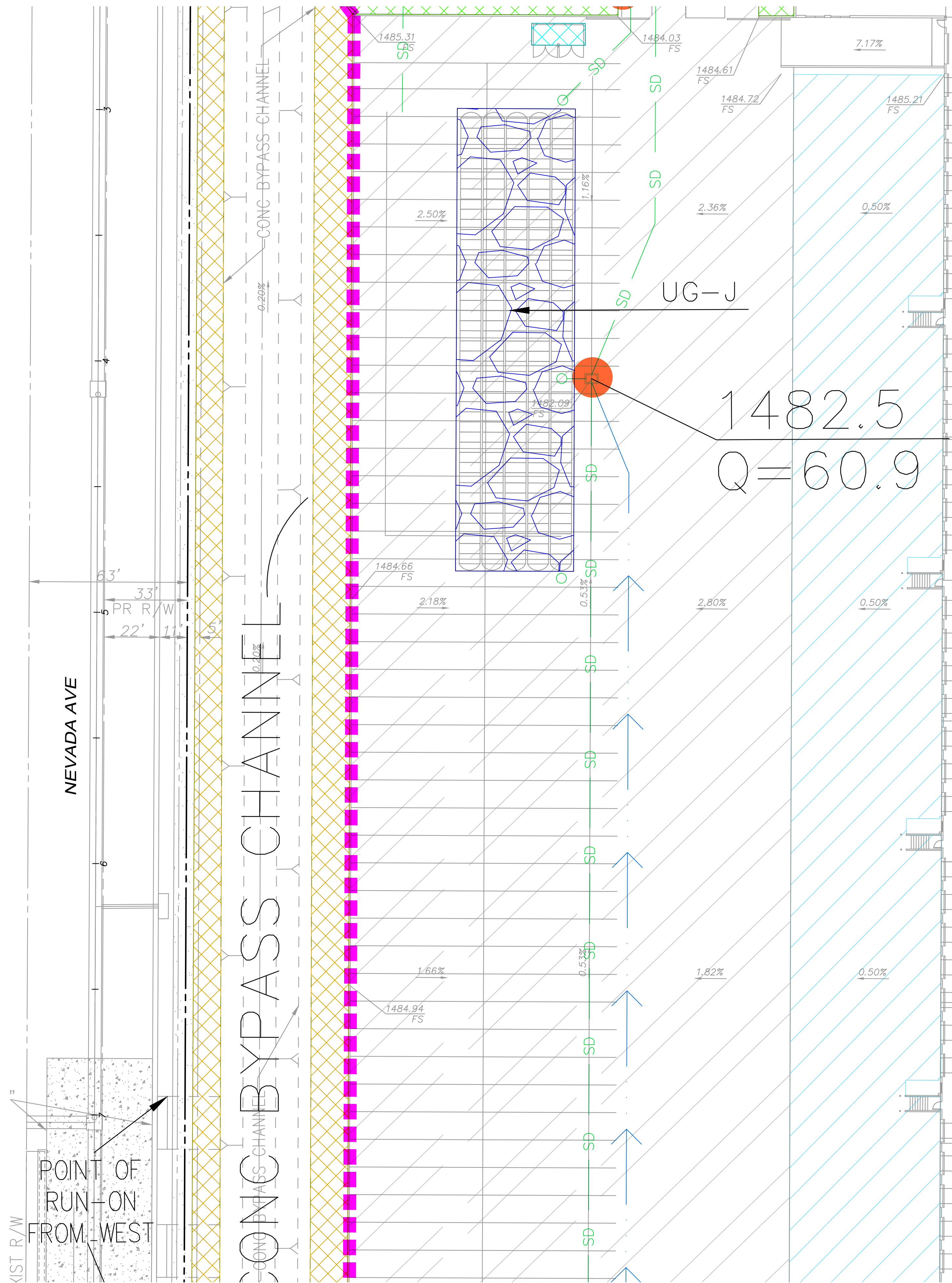

**BUILD**  
 850,224 SF  
 100,000  
**TOTAL =**  
 1489

SEE SHEET 7

- LEGEND**  
 STRUCTURAL / TREATMENT BMPs
- DMA BOUNDARY
  - SD — ONSITE STORM DRAIN
  - LANDSCAPE AREA EFFICIENT IRRIGATION
  - LANDSCAPE AREA RUNOFF-MINIMIZING DESIGN
  - SELF-TREATING LANDSCAPE AREAS NOT TRIBUTARY TO TREATMENT (DMA E)
  - COVERED TRASH ENCLOSURE
  - DOCK AREAS
  - TRAILER AREAS
  - CATCH BASIN STENCIL
  - FLOW PATTERN
  - MODULAR WETLANDS UNIT
  - UNDERGROUND STORAGE ARRAY STORMTECH CHAMBERS (OR EQUAL)
  - DMA DESIGNATION
  - MW— MODULAR WETLANDS UNIT
  - LMW— LINEAR MODULAR WETLANDS UNIT
  - BHDS — BARRACUDA HYDRODYNAMIC SEPARATOR(OR EQUAL)
  - DISCHARGE POINT TO PUBLIC SD

J

RAMONA EXPSWY

2	3
4	5
6	7
8	9

INDEX MAP  
N.T.S.

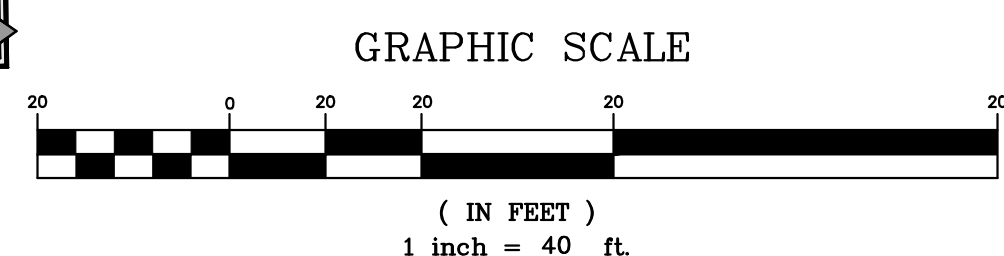
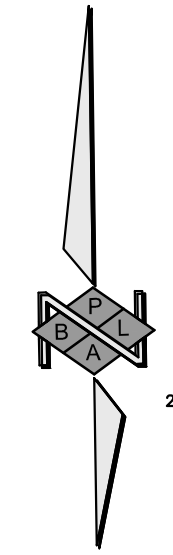

SEE SHEET 8

Sep 15 2022

 <b>PBL ENGINEERING, INC.</b> Planning • Engineering • Surveying 1809 E. DYER ROAD, STE 301 SANTA ANA, CA 92705 (888) 714-9642 • (714)389-9191 FAX	PREPARED BY:	REVISIONS:

**PRELIMINARY POST CONSTRUCTION  
 MASTER BMP SITE PLAN  
 RAMONA GATEWAY COMMERCE CENTER  
 P21-00013 - PERRIS, CA**

JOB NO.  
 139-1  
 SHEET  
 6 of 10

SEE SHEET 5

**BUILDING 1**  
FF FOOTPRINT  
00 SF MEZ  
= 950,224 SF  
39.10 FF

SEE SHEET 6

(K)

SEE SHEET 9

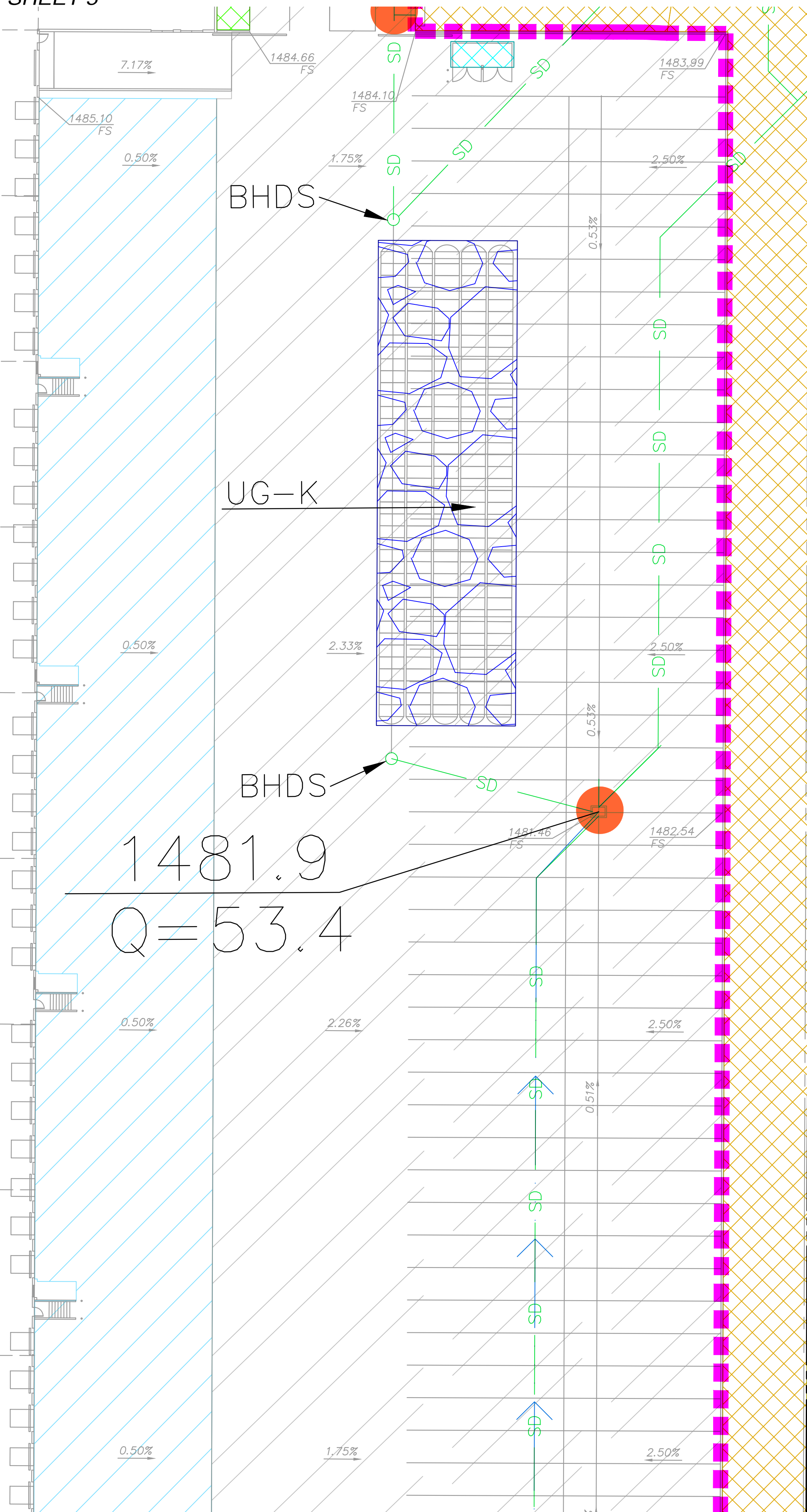

- LEGEND**  
STRUCTURAL / TREATMENT BMPs
- DMA BOUNDARY
  - ONSITE STORM DRAIN
  - LANDSCAPE AREA EFFICIENT IRRIGATION
  - LANDSCAPE AREA RUNOFF-MINIMIZING DESIGN
  - SELF-TREATING LANDSCAPE AREAS NOT TRIBUTARY TO TREATMENT (DMA E)
  - COVERED TRASH ENCLOSURE
  - DOCK AREAS
  - TRAILER AREAS
  - CATCH BASIN STENCIL
  - FLOW PATTERN
  - MODULAR WETLANDS UNIT
  - UNDERGROUND STORAGE ARRAY STORMTECH CHAMBERS (OR EQUAL)
  - (C) DMA DESIGNATION
  - MW- MODULAR WETLANDS UNIT
  - LMW- LINEAR MODULAR WETLANDS UNIT
  - BHDS- BARRACUDA HYDRODYNAMIC SEPARATOR (OR EQUAL)
  - (DP) DISCHARGE POINT TO PUBLIC SD

VACA

WEBSTER AVE

RAMONA EXPSWY

2	3
4	5
6	7
8	9

INDEX MAP  
N.T.S.

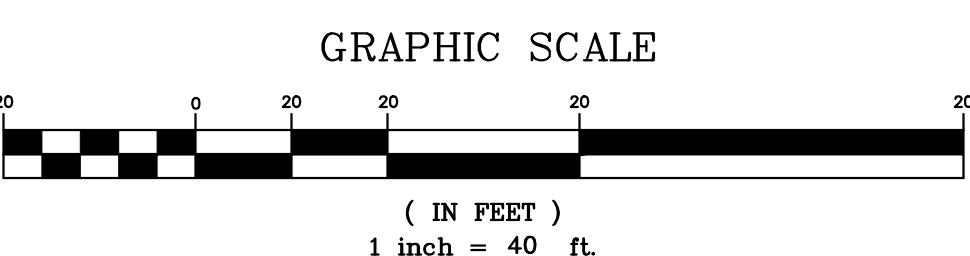
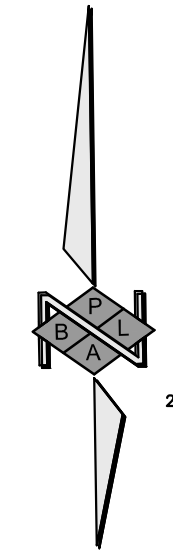

Sep 15 2022

PREPARED BY:  
**PBLA ENGINEERING, INC.**  
Planning • Engineering • Surveying  
1809 E. DYER ROAD, STE 301  
SANTA ANA, CA 92705  
(888) 714-9642 • (714) 389-9191 FAX

REVISIONS:

**PRELIMINARY POST CONSTRUCTION  
MASTER BMP SITE PLAN  
RAMONA GATEWAY COMMERCE CENTER  
P21-00013 - PERRIS, CA**

JOB NO.  
139-1  
SHEET  
7 of 10

SEE SHEET 6

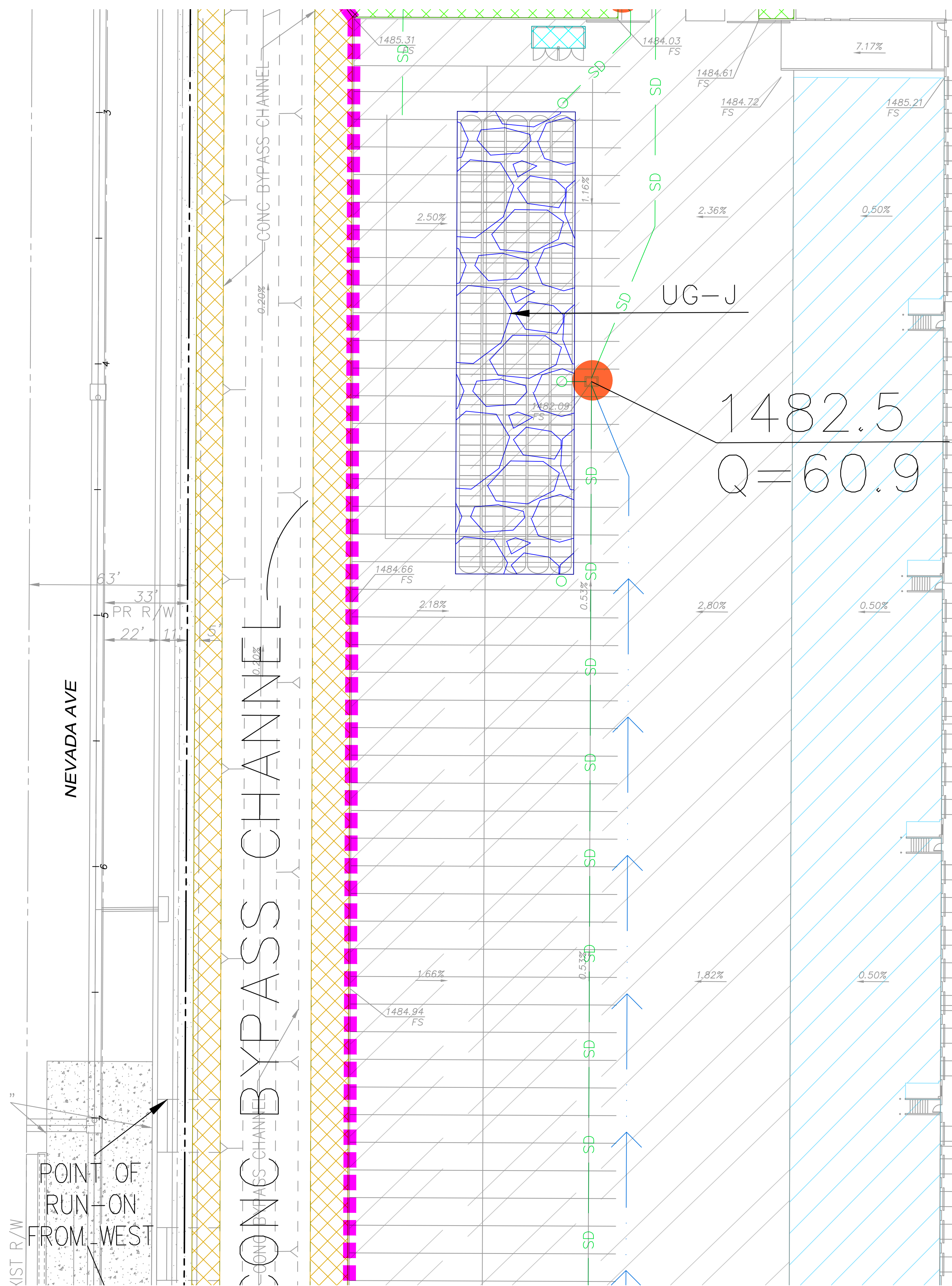

**BUILD**  
 850,224 SF  
 100,000  
 TOTAL =  
 1489

SEE SHEET 9

- LEGEND  
 STRUCTURAL / TREATMENT BMPs
- DMA BOUNDARY
  - ONSITE STORM DRAIN
  - LANDSCAPE AREA EFFICIENT IRRIGATION  
LANDSCAPE AREA RUNOFF-MINIMIZING DESIGN
  - SELF TREATING LANDSCAPE AREAS  
NOT TRIBUTARY TO TREATMENT (DMA E)
  - COVERED TRASH ENCLOSURE
  - DOCK AREAS
  - TRAILER AREAS
  - CATCH BASIN STENCIL
  - FLOW PATTERN
  - MODULAR WETLANDS UNIT
  - UNDERGROUND STORAGE ARRAY  
STORMTECH CHAMBERS (OR EQUAL)
  - DMA DESIGNATION
  - MW- — MODULAR WETLANDS UNIT
  - LMW- — LINEAR MODULAR WETLANDS UNIT
  - BHDS — BARRACUDA HYDRODYNAMIC SEPARATOR (OR EQUAL)
  - DP — DISCHARGE POINT TO PUBLIC SD

J

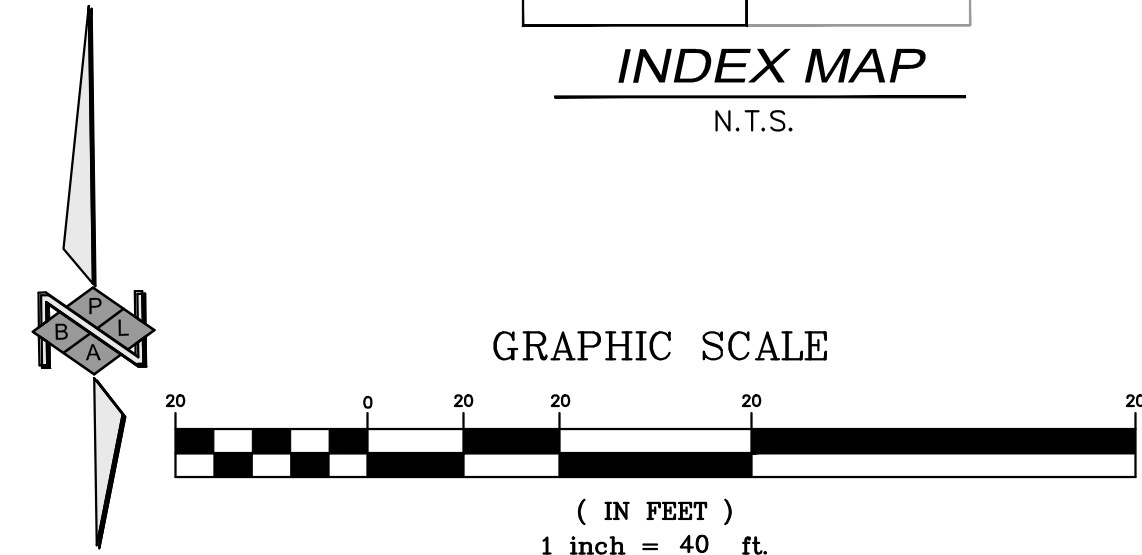
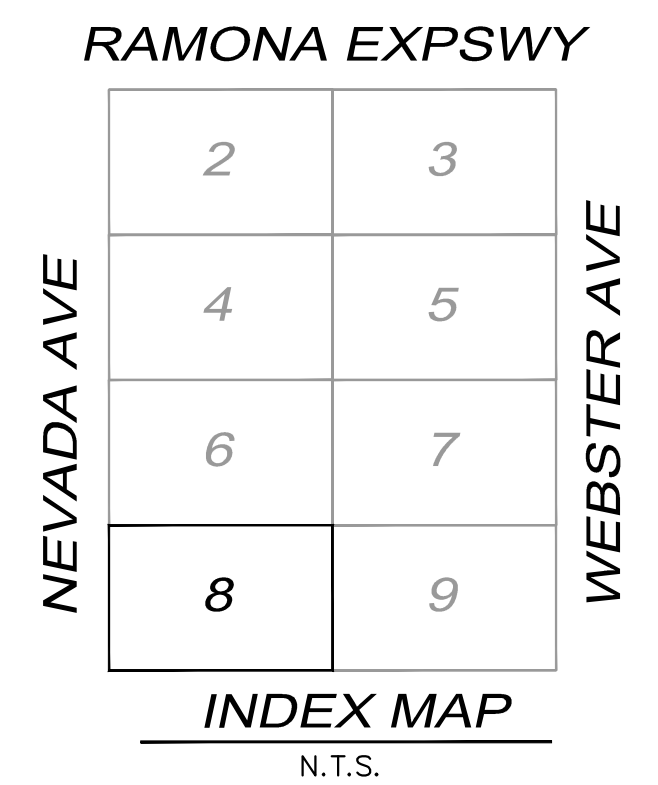

Sep 15 2022

<p><b>PBLA ENGINEERING, INC.</b>          Planning • Engineering • Surveying          1809 E. DYER ROAD, STE 301          SANTA ANA, CA 92705          (888) 714-9642 • (714) 389-9191 FAX</p>	PREPARED BY:	REVISIONS:

**PRELIMINARY POST CONSTRUCTION  
 MASTER BMP SITE PLAN  
 RAMONA GATEWAY COMMERCE CENTER  
 P21-00013 - PERRIS, CA**

JOB NO.  
139-1  
SHEET  
8 of 10

SEE SHEET 7

**LOADING 1**  
**FF FOOTPRINT**  
**00 SF MEZ**  
**= 950,224 SF**  
**39.10 FF**

SEE SHEET 8

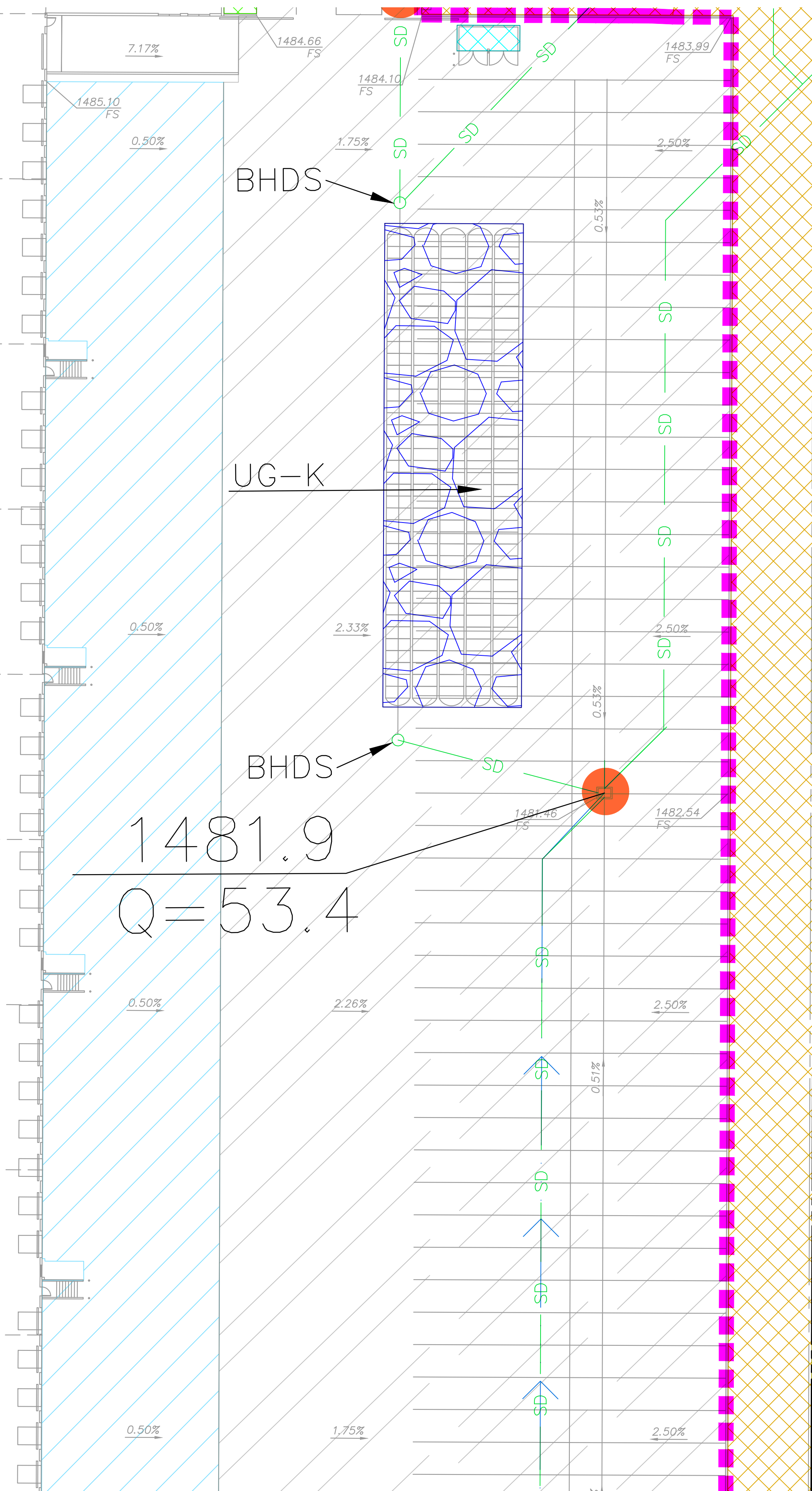

- LEGEND**  
**STRUCTURAL / TREATMENT BMPs**
- DMA BOUNDARY
  - SD — ONSITE STORM DRAIN
  - LANDSCAPE AREA EFFICIENT IRRIGATION
  - LANDSCAPE AREA RUNOFF-MINIMIZING DESIGN
  - SELF TREATING LANDSCAPE AREAS NOT TRIBUTARY TO TREATMENT (DMA E)
  - COVERED TRASH ENCLOSURE
  - DOCK AREAS
  - TRAILER AREAS
  - CATCH BASIN STENCIL
  - FLOW PATTERN
  - MODULAR WETLANDS UNIT
  - UNDERGROUND STORAGE ARRAY STORMTECH CHAMBERS (OR EQUAL)
  - C DMA DESIGNATION
  - MW- MODULAR WETLANDS UNIT
  - LMW- LINEAR MODULAR WETLANDS UNIT
  - BHDS — BARRACUDA HYDRODYNAMIC SEPARATOR (OR EQUAL)
  - DP — DISCHARGE POINT TO PUBLIC SD

DP

47' PR R/W  
 32'

VAC

WEBSTER AVE

1481.9  
 Q=53.4

K

RAMONA EXPSWY

2	3
4	5
6	7
8	9

INDEX MAP  
 N.T.S.

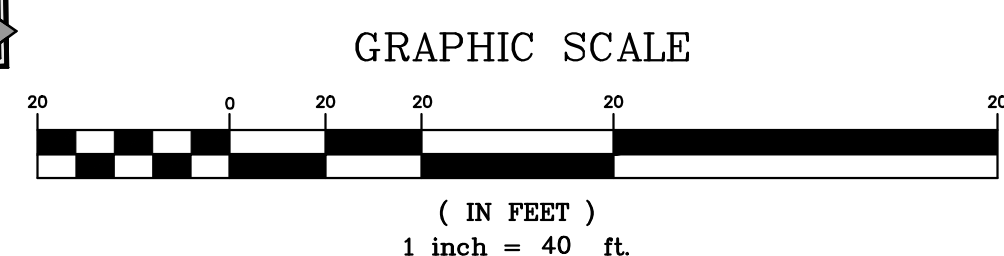
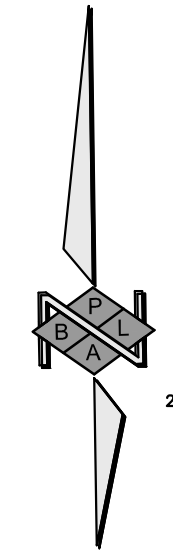

Sep 15 2022

PREPARED BY:  
**PBLA ENGINEERING, INC.**  
 Planning • Engineering • Surveying  
 1809 E. DYER ROAD, STE 301  
 SANTA ANA, CA 92705  
 (888) 714-9642 • (714) 389-9191 FAX

REVISIONS:

**PRELIMINARY POST CONSTRUCTION**  
**MASTER BMP SITE PLAN**  
**RAMONA GATEWAY COMMERCE CENTER**  
 P21-00013 - PERRIS, CA

JOB NO.  
 139-1  
 SHEET  
 9 of 10

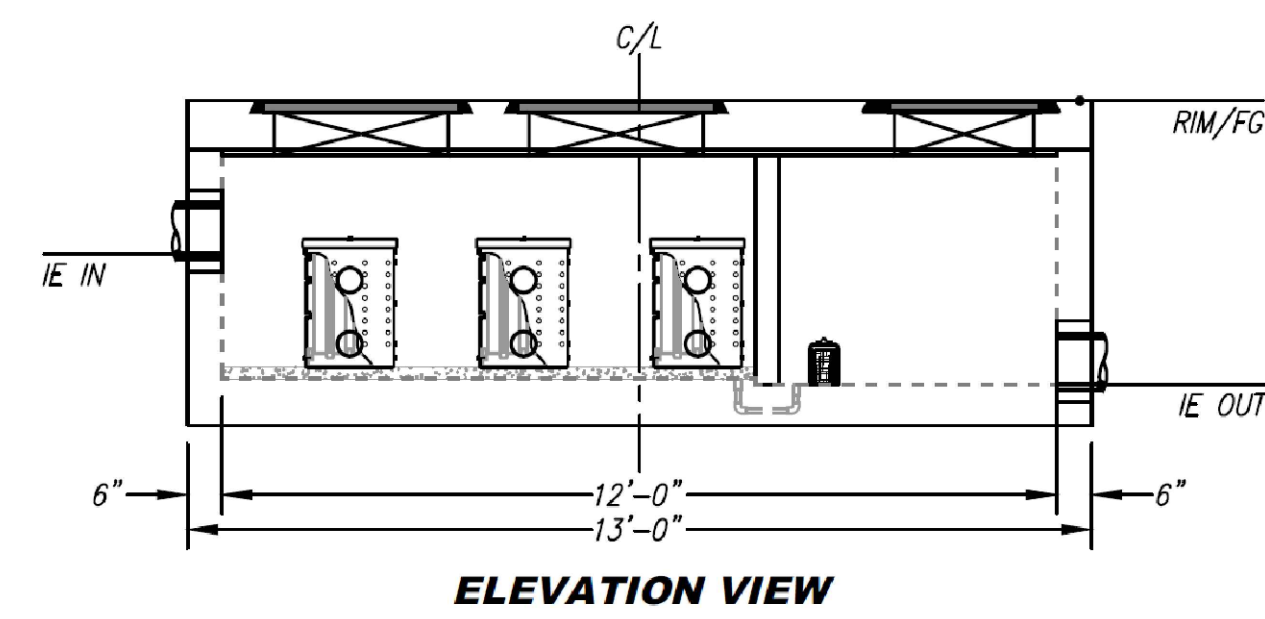

**ELEVATION VIEW**

**TYPICAL MODULAR WETLANDS UNIT**

NTS

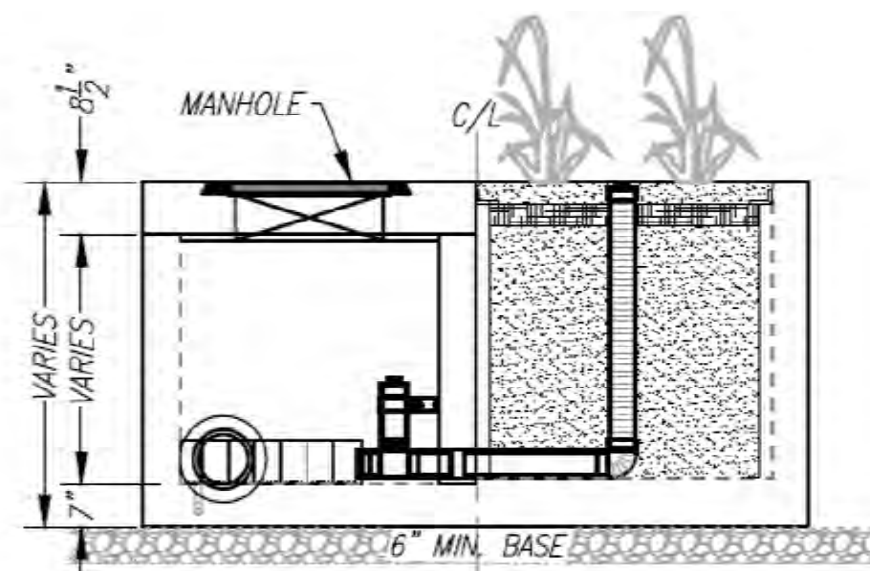

**RIGHT END VIEW**

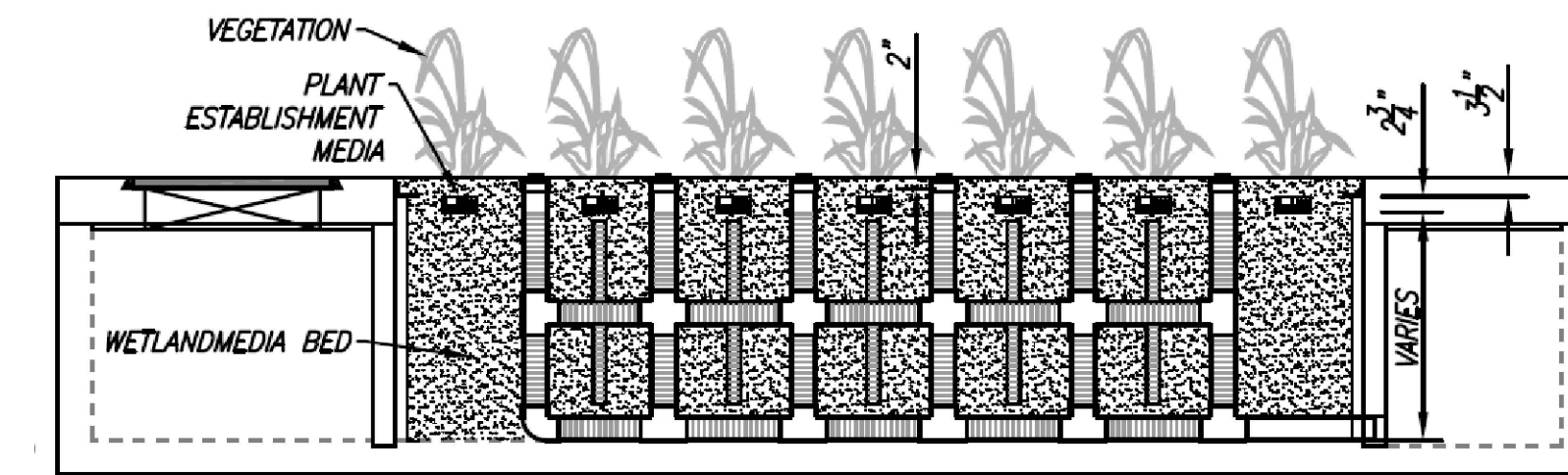

**SECTION VIEW**

**TYPICAL LINEAR MODULAR WETLANDS UNIT**

NTS

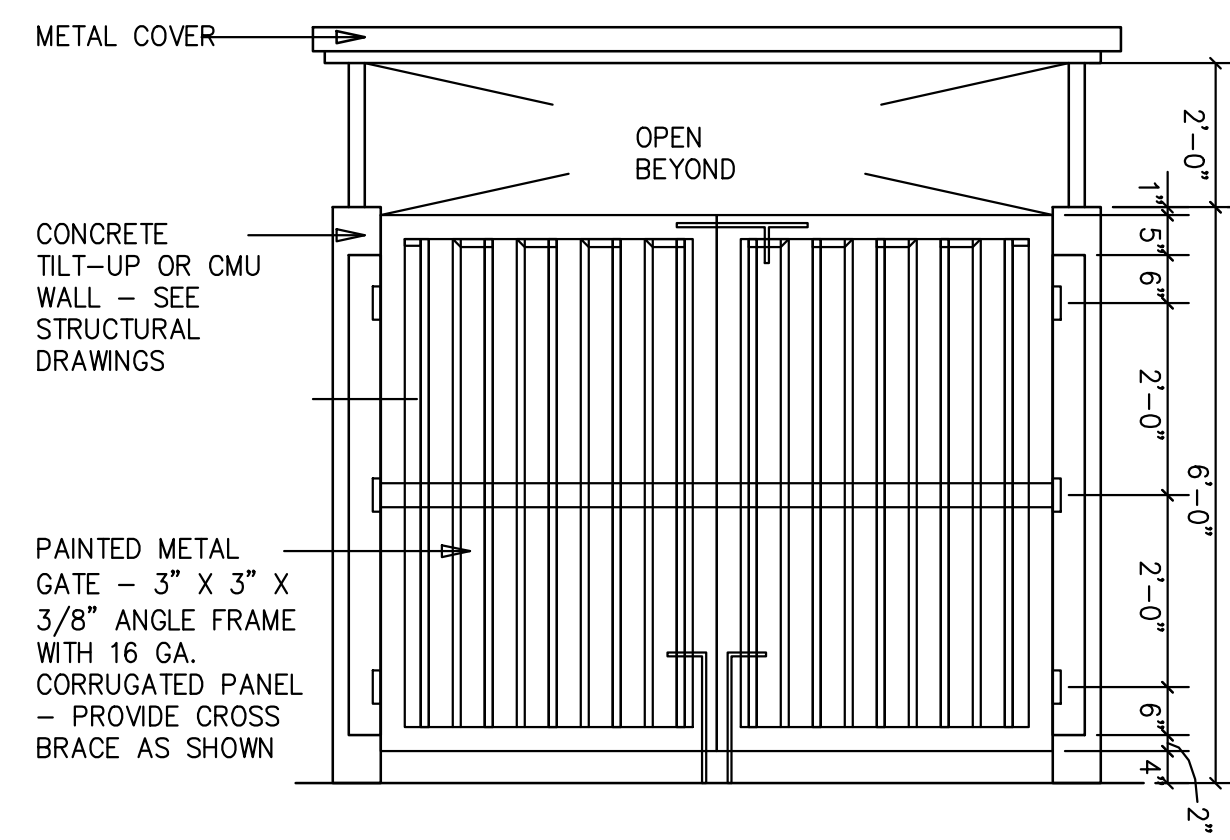

**TYPICAL TRASH ENCLOSURE**

NTS

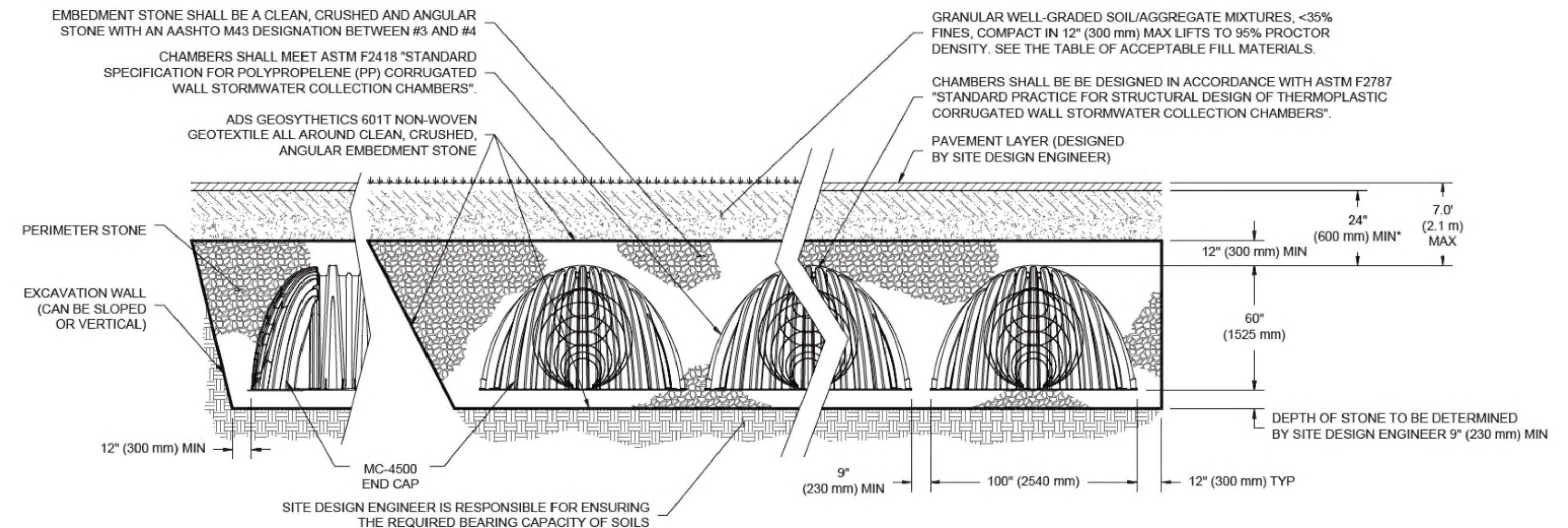

**TYPICAL UNDERGROUND STORAGE SYSTEM**

NTS

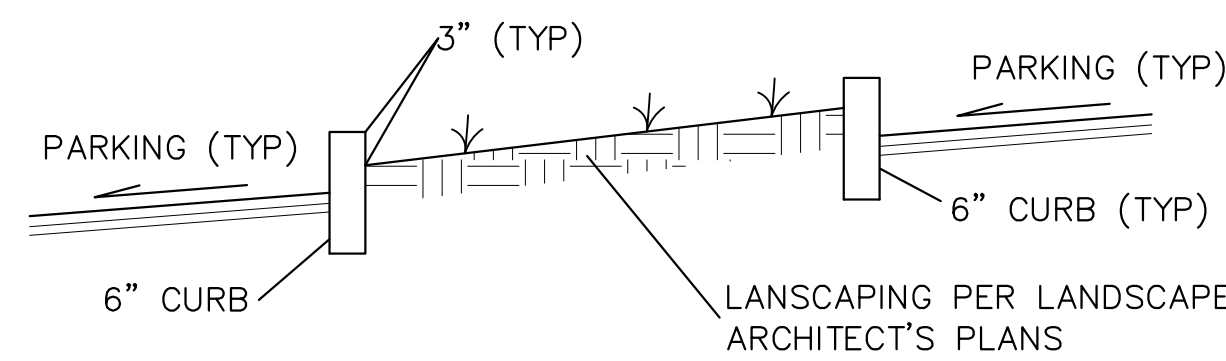

**TYPICAL PLANTER AREA**

NTS

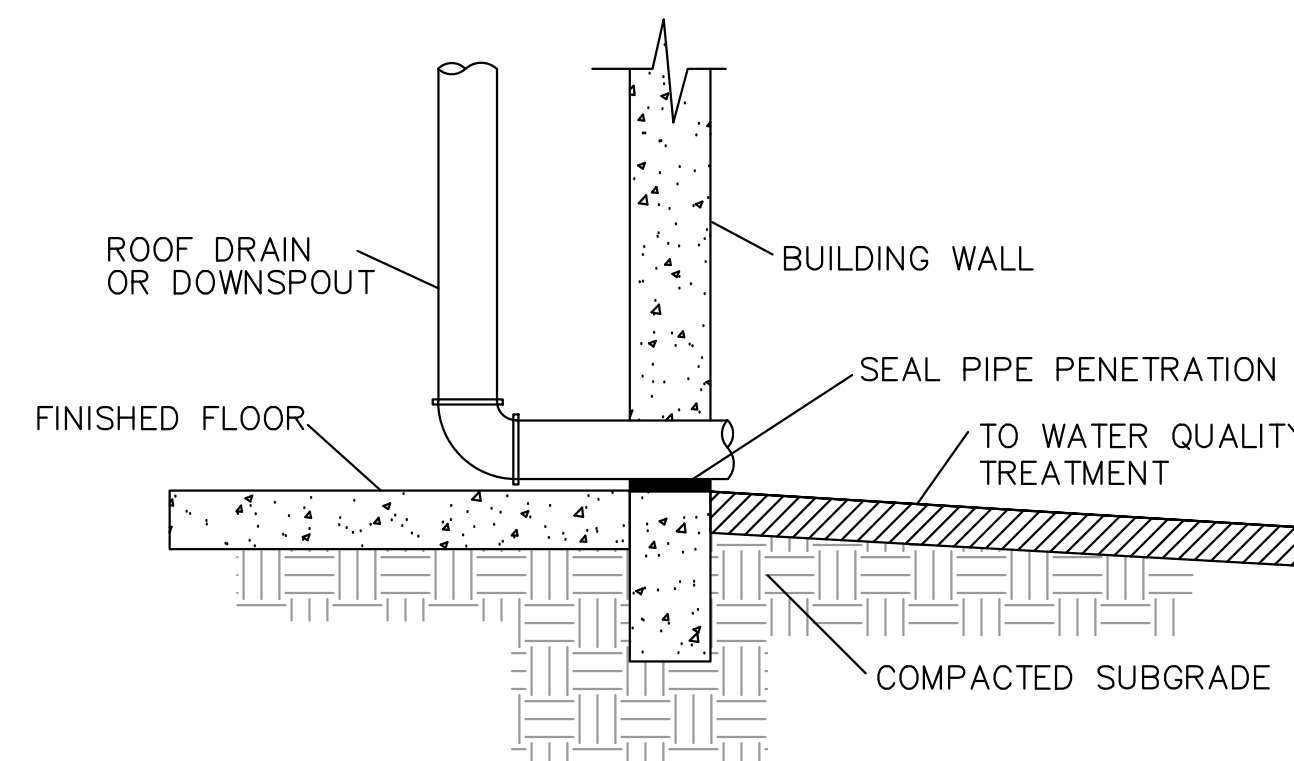

**ROOF DRAIN DETAIL**

NTS

Sep 15 2022

	PREPARED BY:	REVISIONS:
	<b>PBLA ENGINEERING, INC.</b> Planning • Engineering • Surveying 1809 E. DYER ROAD, STE 301 SANTA ANA, CA 92705 (888) 714-9642 • (714) 389-9191 FAX	

**PRELIMINARY POST CONSTRUCTION  
MASTER BMP SITE PLAN  
RAMONA GATEWAY COMMERCE CENTER  
P21-00013 - PERRIS, CA**

JOB NO.  
139-1  
SHEET  
10 of 10

# Appendix 2: Construction Plans

*Grading and Drainage Plans*

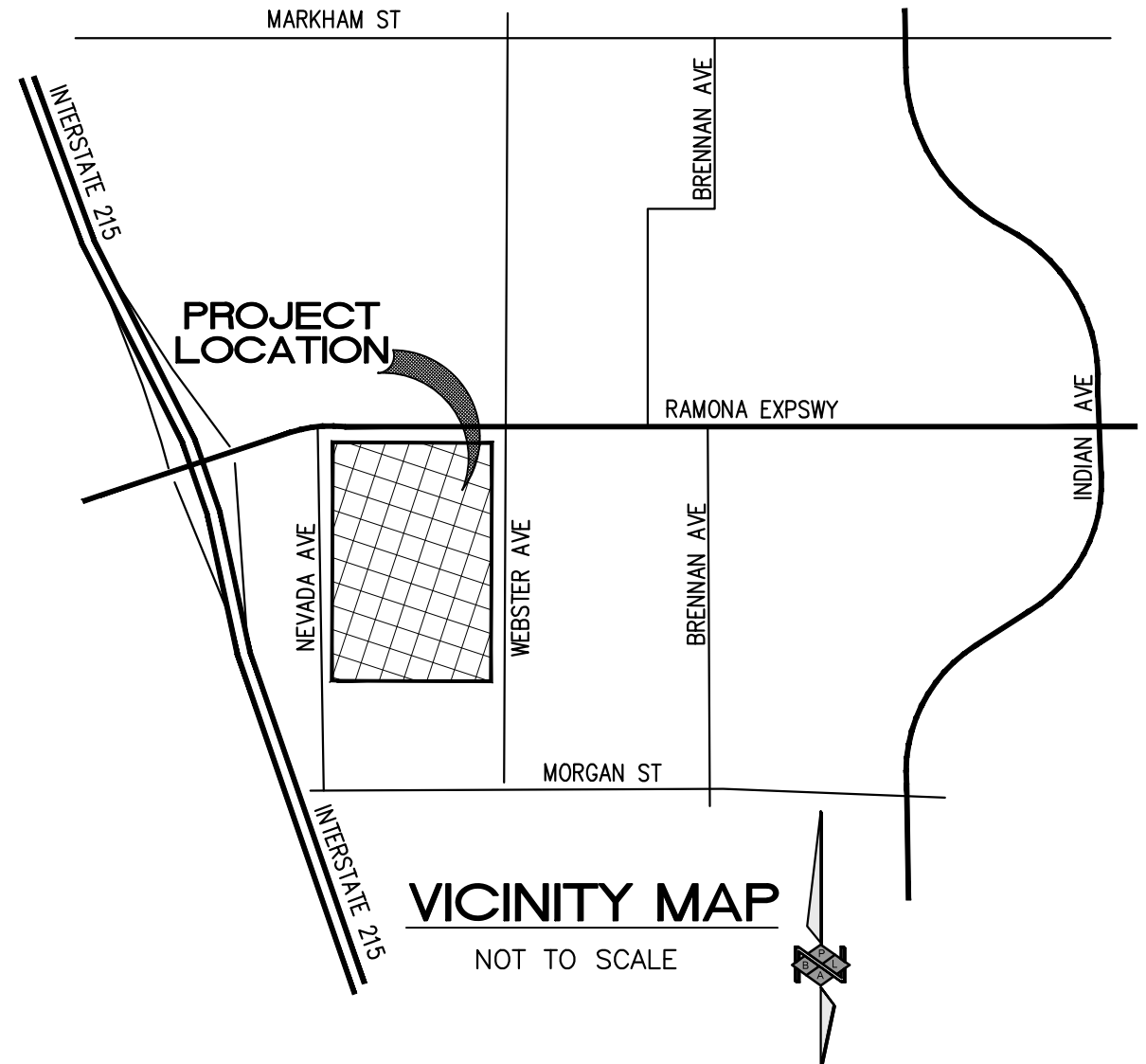
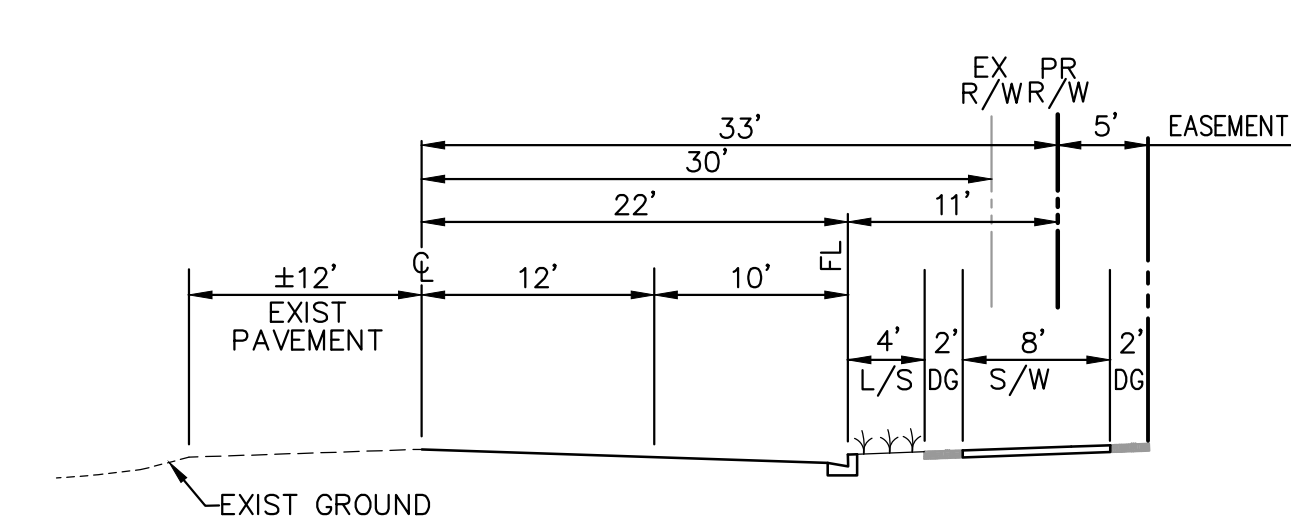
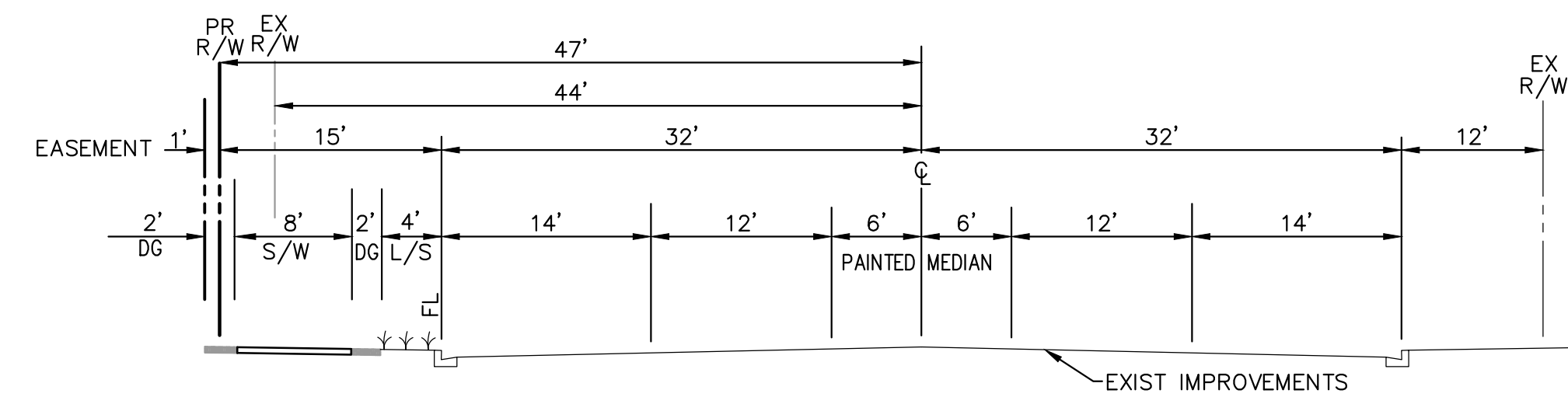
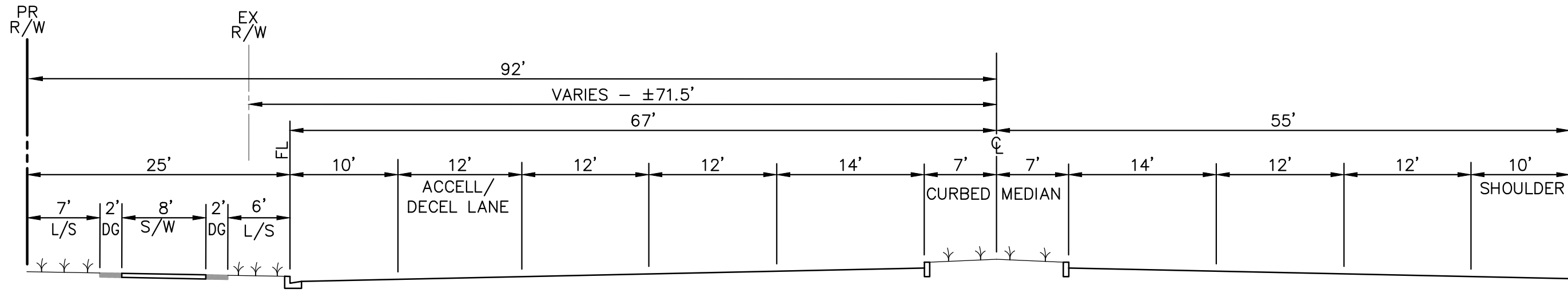

**RAMONA EXPRESSWAY**  
 (EXPRESSWAY)  
 LOOKING WEST - NTS

NOTES:  
 L/S = LANDSCAPE  
 G/C = GROUND COVER  
 S/W = SIDEWALK  
 R/W = RIGHT OF WAY  
 DG = DECOMPOSED GRANITE  
 AC = ASPHALT CONCRETE  
 FL = FLOW LINE  
 PR = PROPOSED

**WEBSTER AVENUE**  
 (SECONDARY ARTERIAL)  
 LOOKING NORTH - NTS

**NEVADA AVENUE**  
 (COLLECTOR)  
 LOOKING NORTH - NTS

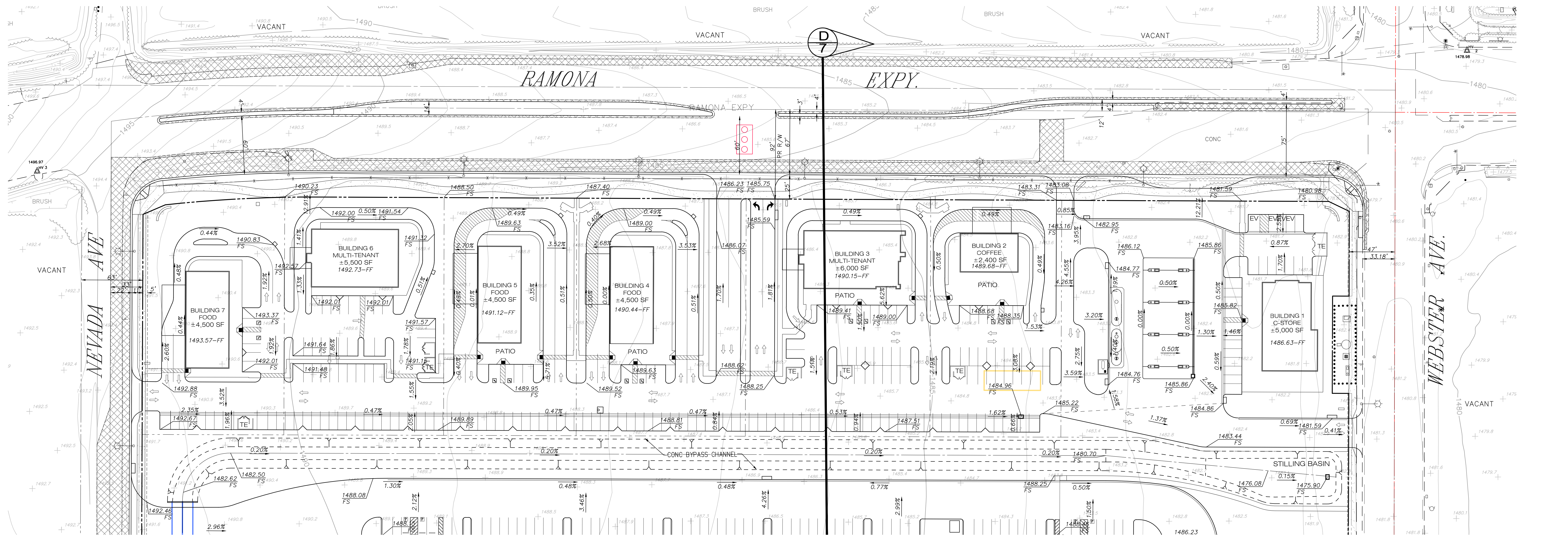

SEE SHIT 2 FOR INDUSTRIAL SITE

**OVERALL OFFSITE IMPROVEMENT QUANTITIES**

DESCRIPTION	QUANTITY
8" CURB & GUTTER	2,762 LF
6" MEDIAN CURB	2,291 LF
4" 10" H.D. PAVEMENT	88,988 SF
6" PCC ARIZONA CROSSING	8,336 SF
ADA ACCESS RAMPS	2 EA
CLASS 1 CONC BIKE PATH	36,679 SF
BUS TURN-OUT	1 EA
CONC DRIVEWAY APPROACH	3,966 SF
REMOVE EX AC PAVEMENT	55,808 SF
REMOVE EX CONC PAVEMENT	1,595 SF
REMOVE EX CURB & GUTTER	107 LF
REMOVE EX CURB ONLY	593 LF
REMOVE EX 4" SIDEWALK	10,448 SF
LANDSCAPE	34,841 SF
MEDIAN LANDSCAPE	4,849 SF
MEDIAN PAVEMENT	2,909 SF

PR AC PAVEMENT

**RETAIL SITE WORK QUANTITIES**

DESCRIPTION	QUANTITY
6" CURB ONLY	8,717 LF
6" CURB & GUTTER	830 LF
4" 10" H.D. PAVEMENT	67,854 SF
6" 16" L.D. PAVEMENT	97,894 SF
6" CONC APRON	2,715 SF
3" RIBBON GUTTER	1,018 LF
ADA RAMPS	24 EA
SIDEWALK	42,568 EA
RETAINING WALL (RETAIL BLD 2)	800 SF

**PRELIMINARY EARTHWORK QUANTITIES**

NET VOLUMES	CUT	FILL
RETAIL SITE	14,600 CY	30,200 CY
INDUSTRIAL SITE	227,500 CY	211,900 CY
<b>TOTALS</b>	<b>242,100 CY</b>	<b>242,100 CY</b>

--- BALANCE ---

**LEGAL DESCRIPTION / AP NUMBERS**  
 A PTN OF LOT 20 PERRY'S SUBDIVISION, BK 7/PG 25 OF MAPS, TOGETHER WITH LOT 1, BLK 9 VAL VERDE TRACT, BK 1/PG 6 OF MAPS, TOGETHER WITH A PTNS OF LOT 22 PERRY'S RE-SUBDIVISION, BK 7/PG 45 OF MAPS, ALL OF OFFICIAL RECORDS, COUNTY OF RIVERSIDE. APN: 317-120-021 317-130-017, 021, 025, 048

DATE	BY	REVISION

**SOILS ENGINEER**  
**SOUTHERN CALIFORNIA GEOTECHNICAL**  
 22886 YAVI RANCH PKWY, SUITE E  
 SANTA ANA, CA 92787

**PREPARED FOR:**  
**PERRIS LANDCO, LLC**  
 201 SPEAR STREET #100  
 SAN FRANCISCO, CA 94105

**BENCHMARK DESCRIPTION**  
 A STANDARD 3-1/4 INCH ALUMINUM DISK SET FLUSH AT THE NORTHEAST CORNER OF CAJALCO RD AND SEATON AVE, 65 FEET NORTH OF CAJALCO RD AND 32 FEET EAST OF SEATON AVE, ON THE FOOTING OF A LARGE STEEL POWER POLE 705640/01 ON LOWER FOOTING. ELEV: 1557.17 - NAVD 88

**PREPARED BY:**  
**PBLA ENGINEERING, INC.**  
 Planning • Engineering • Surveying  
 1809 E DYER ROAD, SITE 301  
 SANTA ANA, CALIF. 92705  
 (888) 714-9642 • (714) 389-9191 FAX

**CONCEPT GRADING PLAN**  
**RETAIL SITE**  
**RAMONA GATEWAY COMMERCE CENTER**

WO 139-1  
 Sht 1 of 7

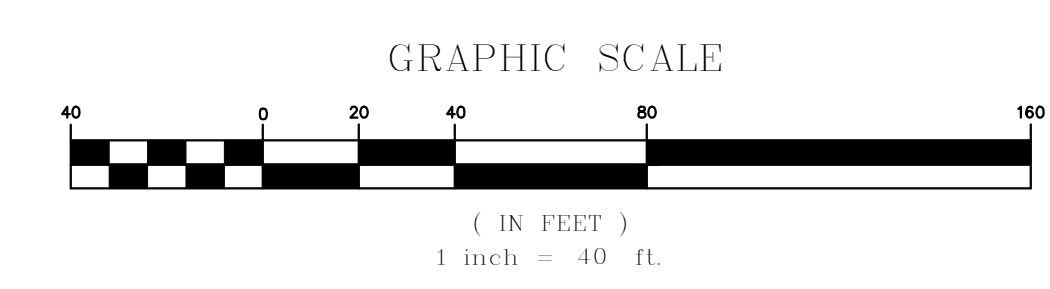

Sep 23 2022

SEE SHT 1 FOR RETAIL SITE

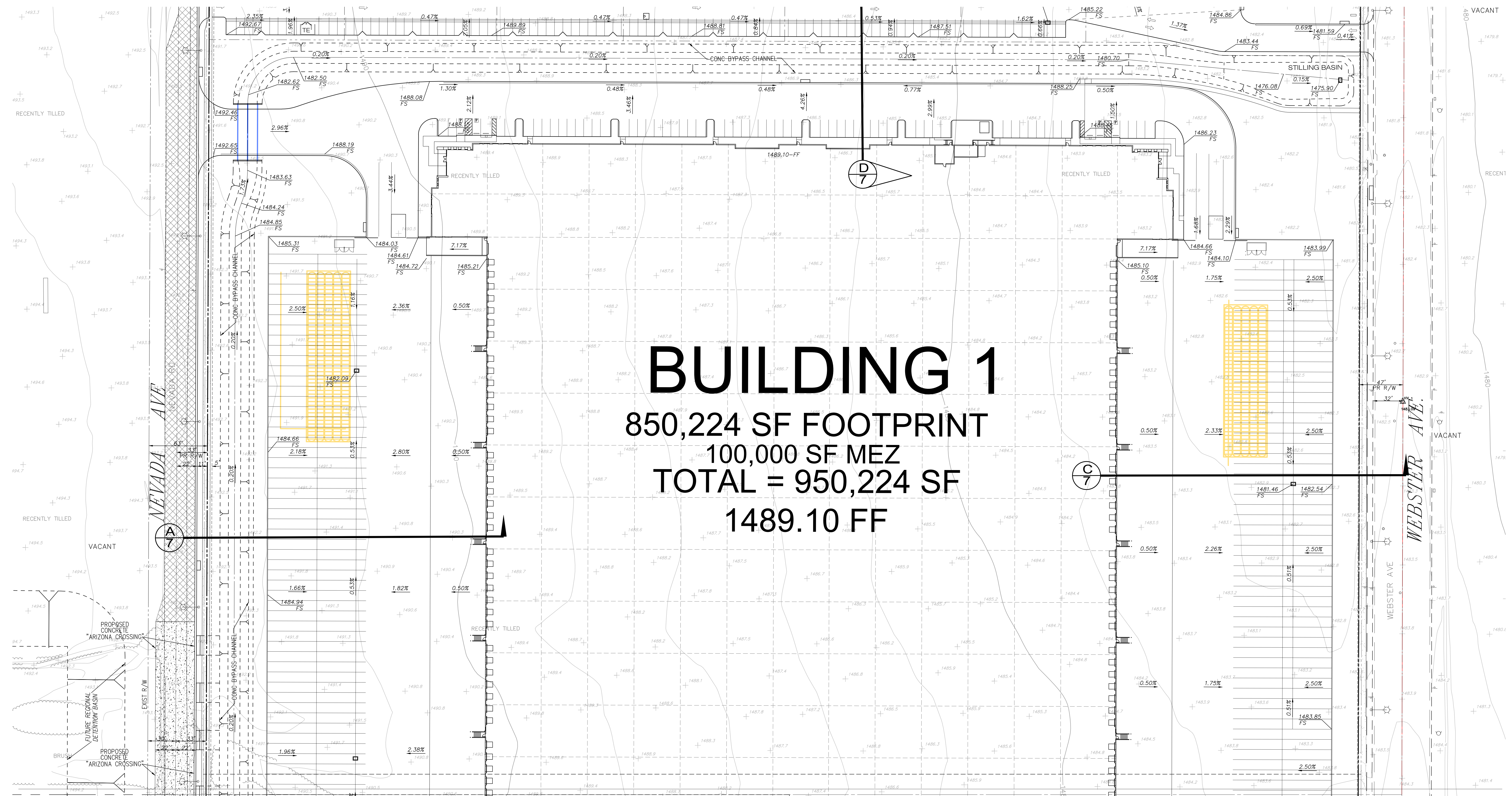

SEE SHT 3 FOR CONTINUATION

**INDUSTRIAL SITE WORK QUANTITIES**

DESCRIPTION	QUANTITY
6" CURB ONLY	7,787 LF
6" CURB & GUTTER	3,186 LF
5.5" CONC H.D. PAVEMENT	413,716 SF
3" 6" L.D. PAVEMENT	97,002 SF
5.5" CONC APRON	149,876 SF
ADA RAMPS	15 EA
SIDEWALK	9,557 EA
RETAINING WALL	0 SF

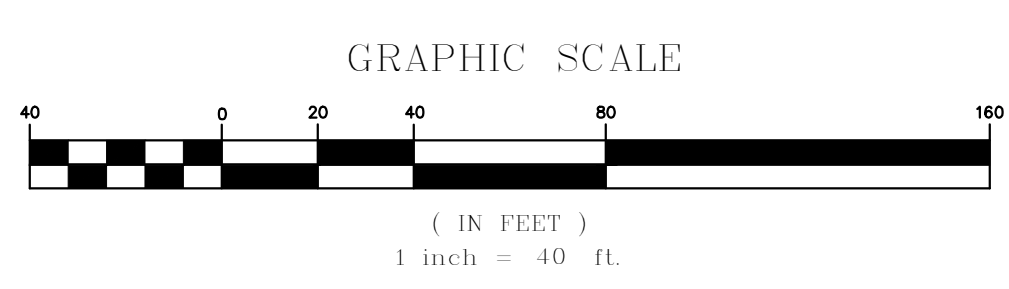
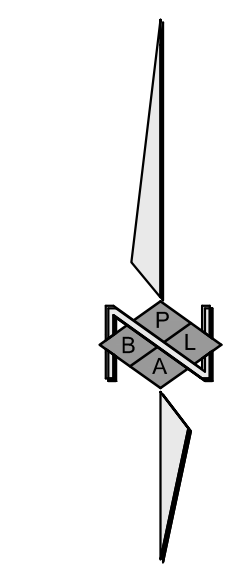

Sep 23 2022

DATE	BY	REVISION

PREPARED FOR:  
**PERRIS LANDCO, LLC**  
 201 SPEAR STREET #100  
 SAN FRANCISCO, CA 94105

PREPARED BY:  

**PBLA ENGINEERING, INC.**  
 Planning • Engineering • Surveying  
 1809 E. DYER ROAD, SITE 301  
 SANTA ANA, CALIF. 92705  
 (888) 714-9642 • (714) 389-9191 FAX

TOPOGRAPHY DATE: 12-23-20  
 CITY OF PERRIS  
**CONCEPT GRADING PLAN**  
**INDUSTRIAL SITE**  
**RAMONA GATEWAY COMMERCE CENTER**

WO 139-1  
 Sht. 2 of 7

SEE SHIT 2 FOR CONTINUATION

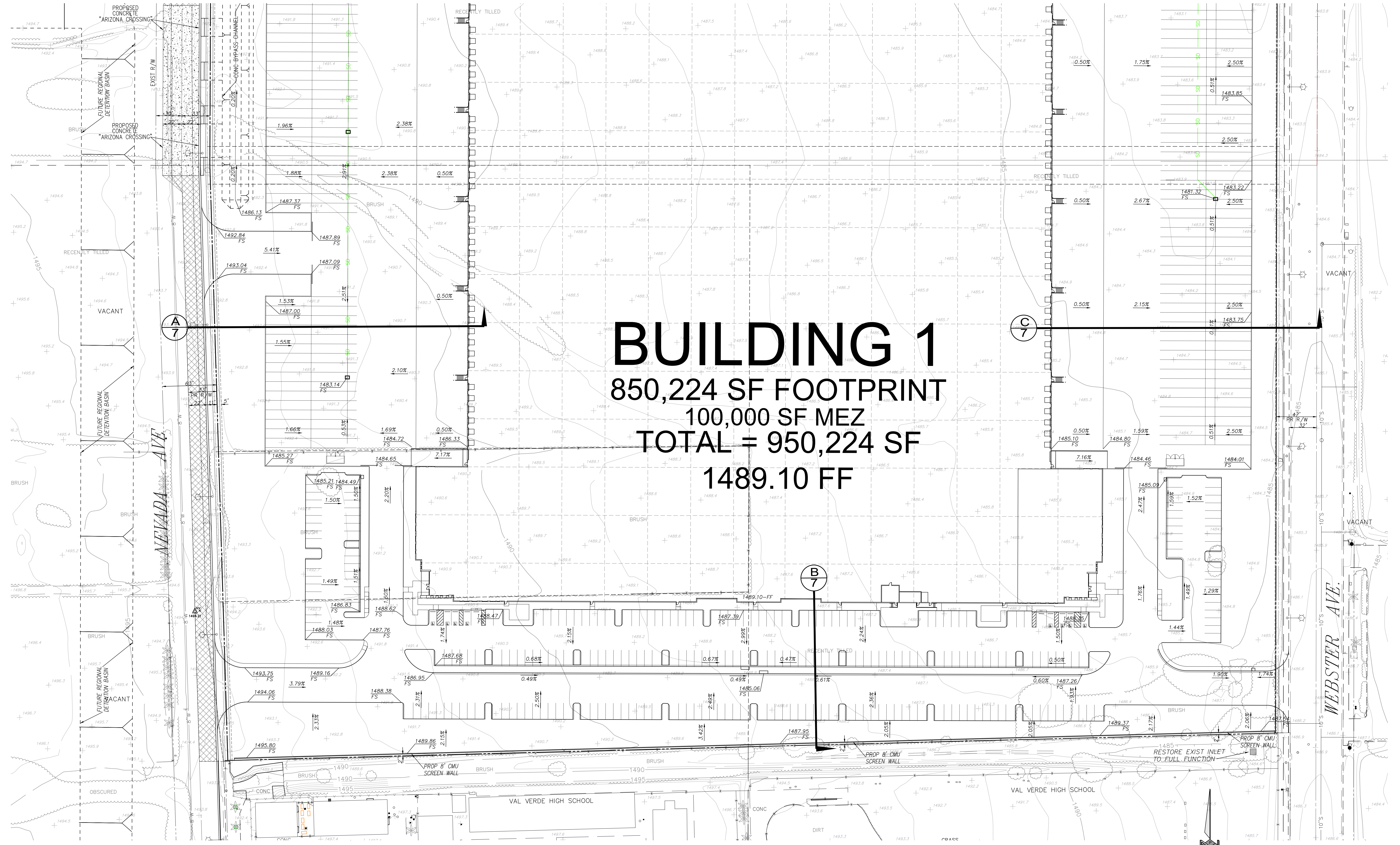

**BUILDING 1**  
**850,224 SF FOOTPRINT**  
**100,000 SF MEZ**  
**TOTAL = 950,224 SF**  
**1489.10 FF**

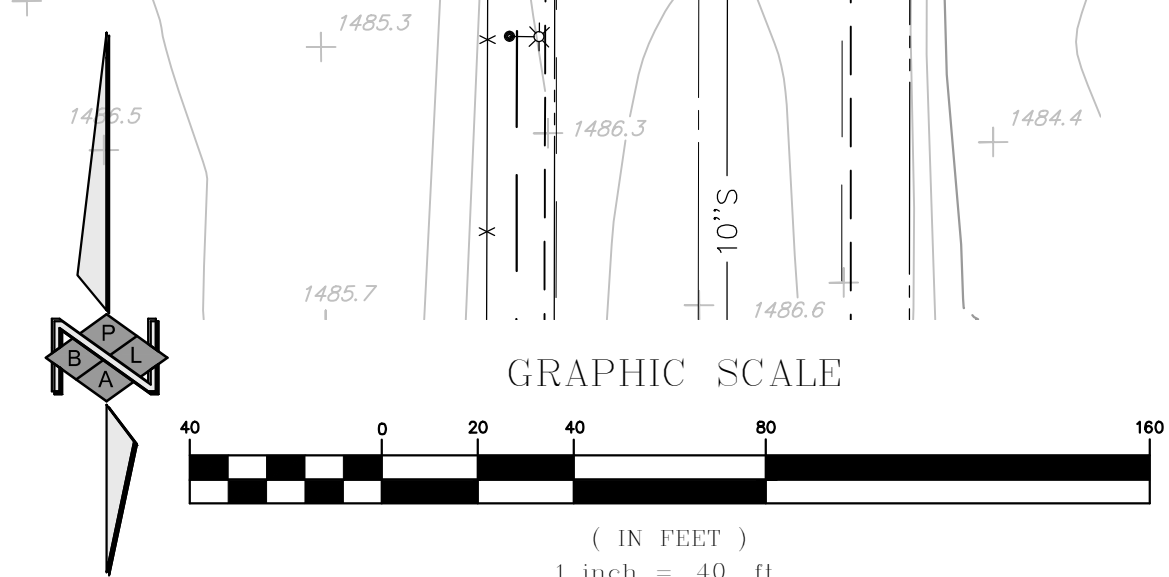

Sep 23 2022

DATE	BY	REVISION

PREPARED FOR:  
**PERRIS LANDCO, LLC**  
 201 SPEAR STREET #100  
 SAN FRANCISCO, CA 94105

PREPARED BY:  
  
**PBLA ENGINEERING, INC.**  
 Planning • Engineering • Surveying  
 1809 E DYER ROAD, STE 301  
 SANTA ANA, CALIF. 92705  
 (888) 714-9642 • (714) 389-9191 FAX

CITY OF PERRIS  
**CONCEPT GRADING PLAN**  
**INDUSTRIAL SITE**  
**RAMONA GATEWAY COMMERCE CENTER**

WO 139-1  
 Sht. 3 of 7

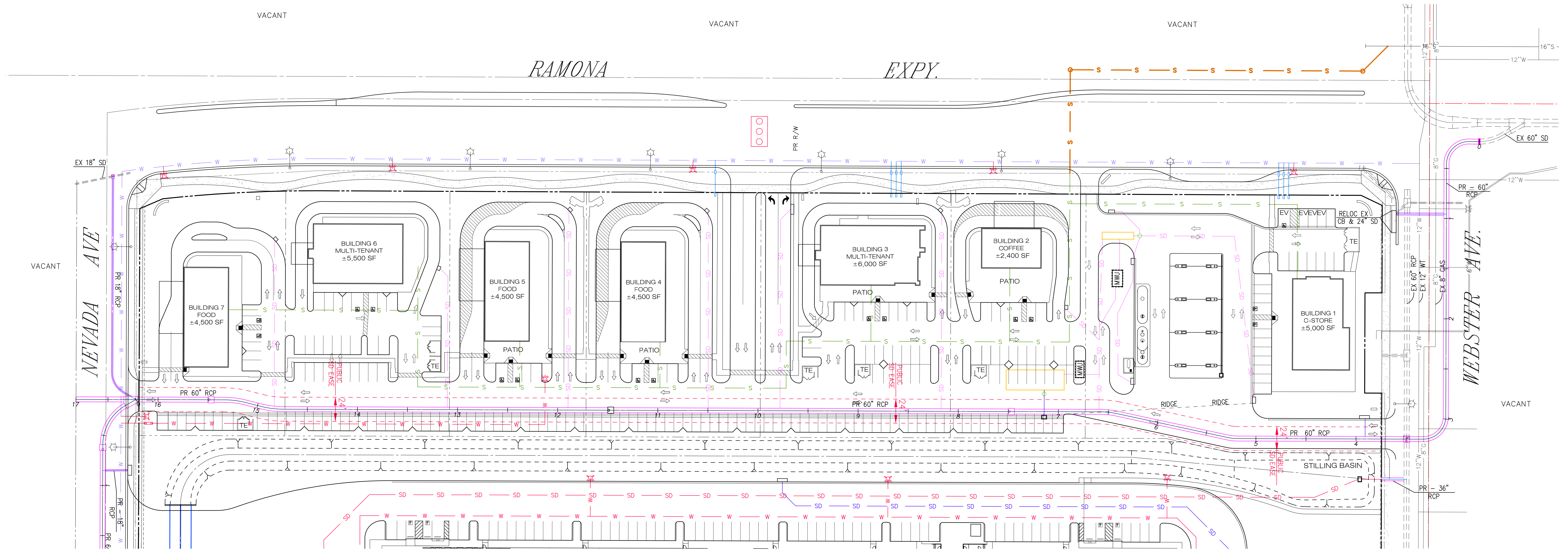

SEE SHT 5 FOR INDUSTRIAL SITE

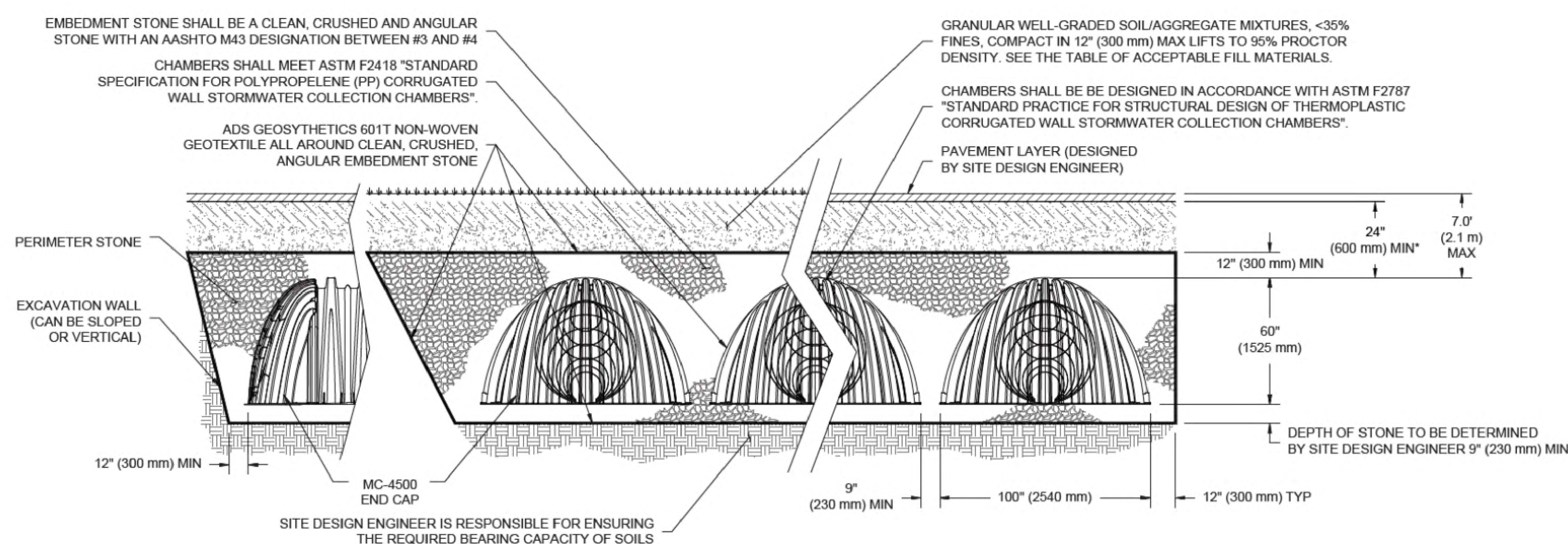

\*MINIMUM COVER TO BOTTOM OF FLEXIBLE PAVEMENT. FOR UNPAVED INSTALLATIONS WHERE RUTTING FROM VEHICLES MAY OCCUR, INCREASE COVER TO 30" (750 mm).

TYPICAL UNDERGROUND STORAGE SYSTEM

NTS

RETAIL SITE UTILITY QUANTITIES	
DESCRIPTION	QUANTITY
12" STORM DRAIN	2,135 LF
18" STORM DRAIN	594 LF
U/G STORAGE SYSTEM	333 LF
CATCH BASINS	12 EA
MODULAR WETLANDS UNIT	2 EA
6" SEWER	1,696 LF
1-1/2" DOMESTIC WATER	933 LF
1.5" DOMESTIC WATER METER & BF	4 EA
6" FIRE WATER LATERAL	449 LF
FIRE HYDRANT	1 EA

OVERALL PUBLIC UTILITY QUANTITIES	
DESCRIPTION	QUANTITY
18" STORM DRAIN	285 LF
24" STORM DRAIN	5 LF
36" STORM DRAIN	160 LF
60" STORM DRAIN	2,414 LF
MANHOLES	8 EA
JUNCT STRUCTURE	1 EA
CATCH BASIN/LOCAL DEPR	8 EA
CUSTOM INLET STRUCTURE	1 EA
8" VCP SEWER	431 LF
45" SEWER MANHOLE	2 EA
WYE CONNECTION TO EX 16"	1 EA
8" CML&C WATER	962 LF
12" CML&C WATER	1,297 LF
8" VALVES	3 LF
12" VALVES	6 LF
6" HYDRANT LATERAL	127 LF
6" DETECTOR CHECK VALVE	1 EA
10" DETECTOR CHECK VALVE	2 EA
FIRE HYDRANT	8 EA
STREET LIGHT	24 EA

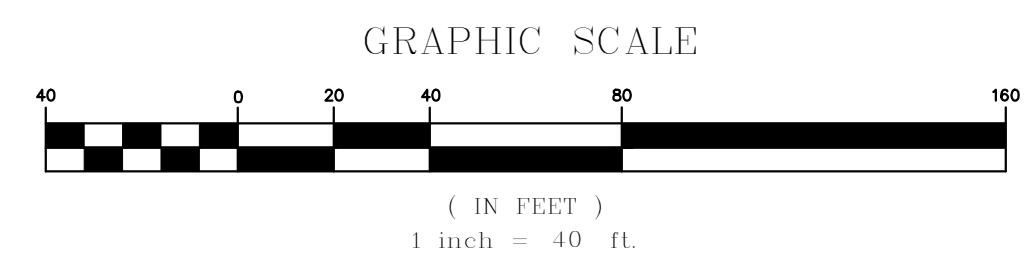

Sep 23 2022

DATE	BY	REVISION	PREPARED FOR:	PREPARED BY:	CITY OF PERRIS	WO
			<b>PERRIS LANDCO, LLC</b> 201 SPEAR STREET #100 SAN FRANCISCO, CA 94105	<b>PBLA ENGINEERING, INC.</b> Planning • Engineering • Surveying 1809 E. DYER ROAD, STE 301 SANTA ANA, CALIF. 92705 (888) 714-9642 • (714)389-9191 FAX	<b>CONCEPT UTILITY PLAN</b> <b>RETAIL SITE</b> <b>RAMONA GATEWAY COMMERCE CENTER</b>	139-1

SEE SHT 4 FOR RETAIL SITE

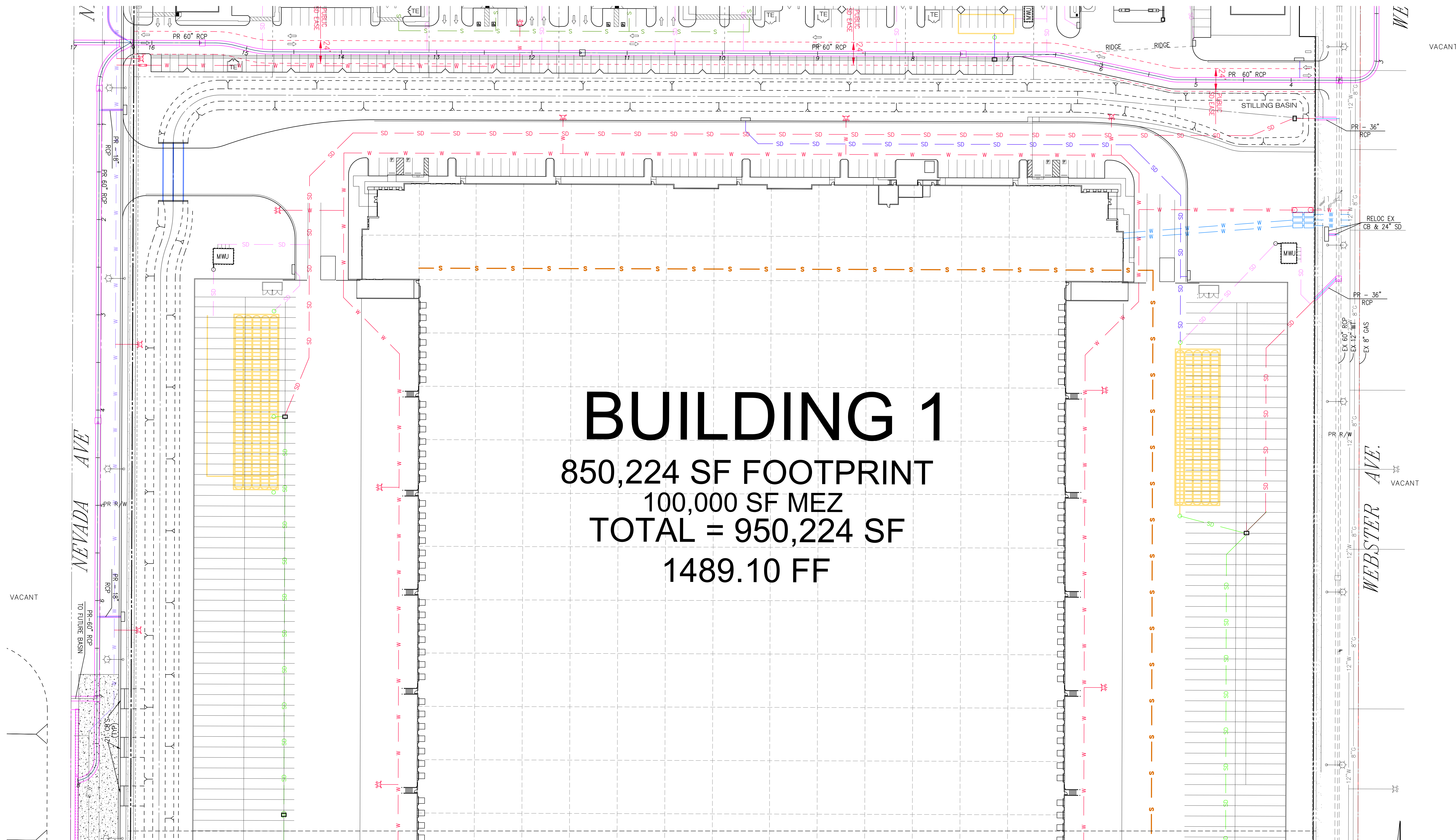

**BUILDING 1**  
 850,224 SF FOOTPRINT  
 100,000 SF MEZ  
 TOTAL = 950,224 SF  
 1489.10 FF

SEE SHT 6 FOR CONTINUATION

**INDUSTRIAL SITE UTILITY QUANTITIES**

DESCRIPTION	QUANTITY
12" STORM DRAIN	1,199 LF
18" STORM DRAIN	1,584 LF
24" STORM DRAIN	954 LF
36" STORM DRAIN	1,640 LF
U/G STORAGE SYSTEM	4,000 LF
BYPASS CHANNEL PER DETAIL	1,943 LF
20' W X 4' H RCB	60 LF
RCB HEADWALL	2 EA
MODULAR WETLANDS UNIT	2 EA
WET WELL/1 HP SUMP PUMP	2 EA
6" SEWER	1,119 LF
8" SEWER	2,153 LF
3" DOMESTIC WATER	713 LF
1.5" DOMESTIC WATER METER & BF	6 EA
10" FIRE WATER MAIN	5,047 LF
8" FIRE RISER LATERAL	200 LF
6" FIRE WATER LATERAL	406 LF
FIRE HYDRANT	14 EA

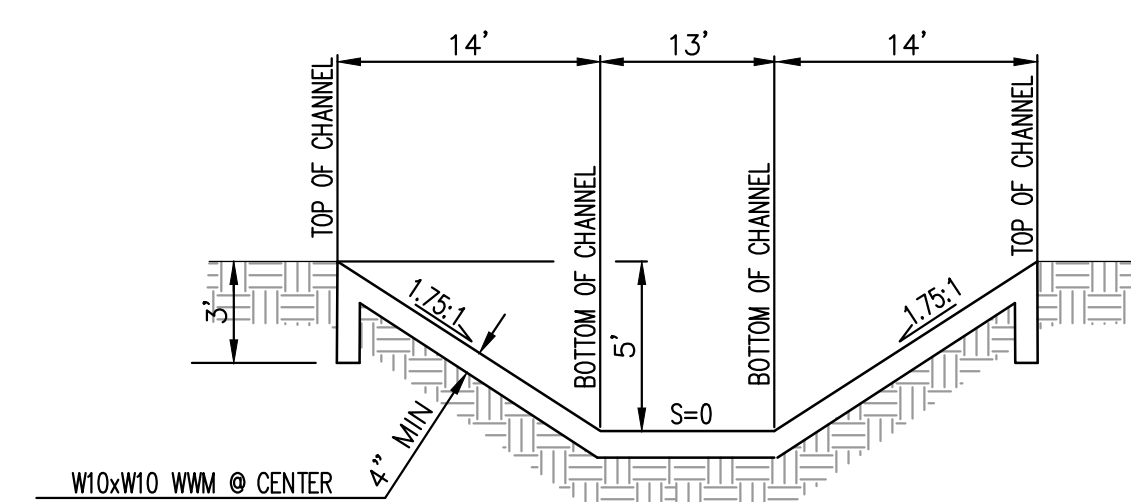

PROPOSED CONC CHANNEL  
N.T.S.

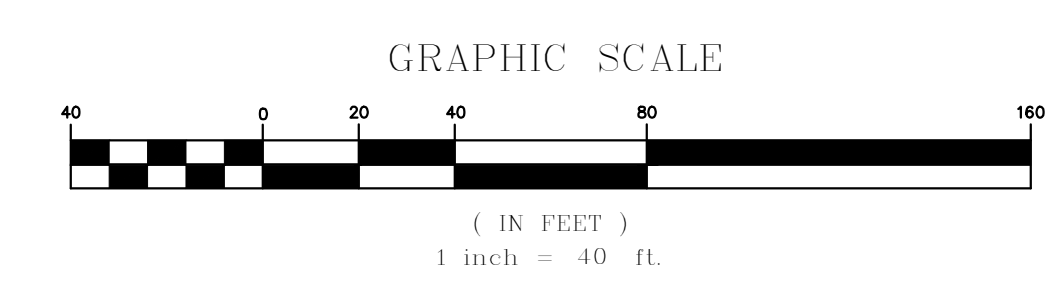

Sep 23 2022

DATE	BY	REVISION	PREPARED FOR:	PREPARED BY:	CITY OF PERRIS	WO
			<b>PERRIS LANDCO, LLC</b> 201 SPEAR STREET #100 SAN FRANCISCO, CA 94105	<b>PBLA ENGINEERING, INC.</b> Planning • Engineering • Surveying 1809 E. DYER ROAD, STE 301 SANTA ANA, CALIF. 92705 (888) 714-9642 • (714)389-9191 FAX	<b>CONCEPT UTILITY PLAN INDUSTRIAL SITE</b>	139-1
					<b>RAMONA GATEWAY COMMERCE CENTER</b>	Sht. 5 of 7

SEE SHT 5 FOR CONTINUATION

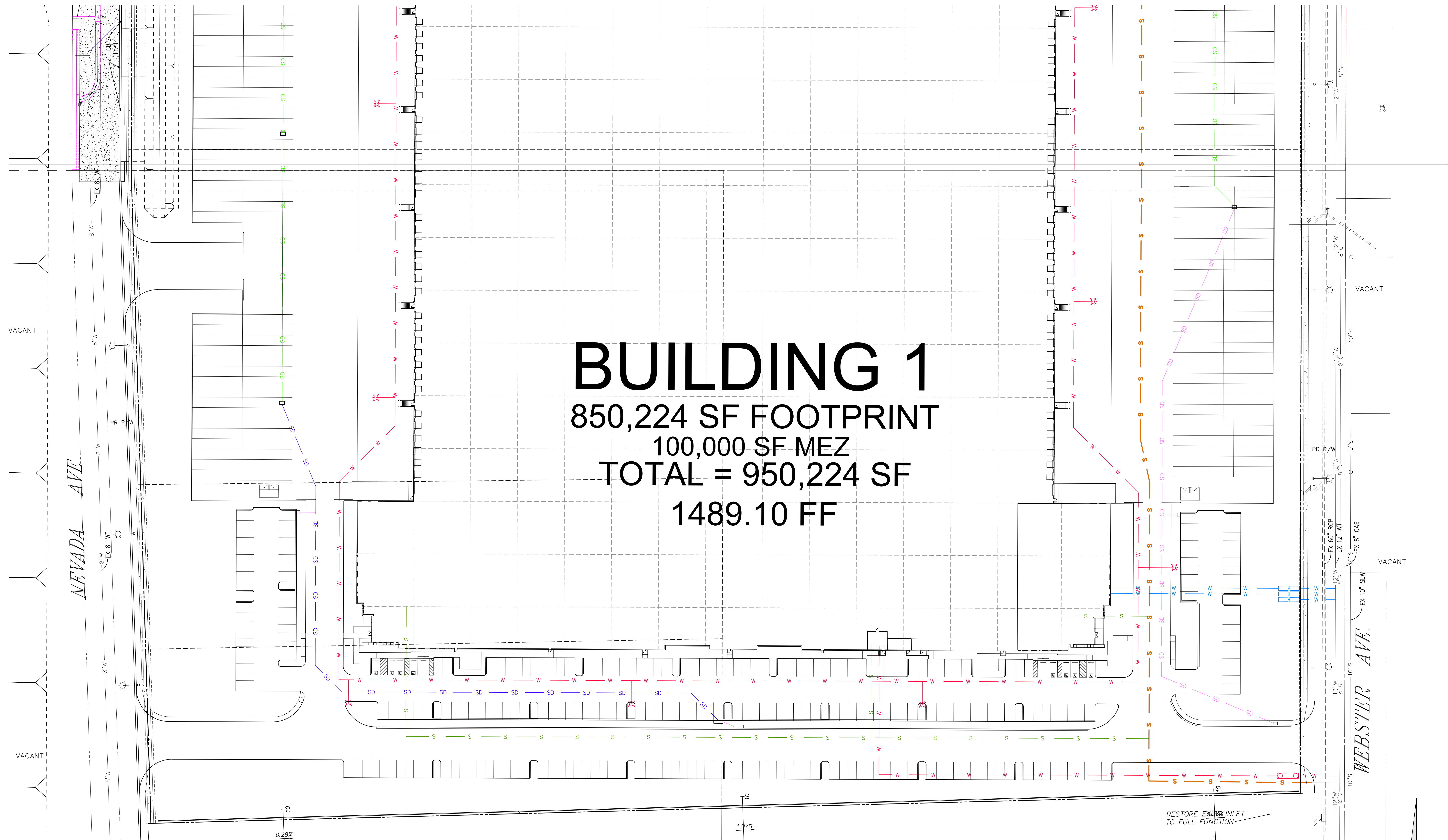

**BUILDING 1**  
 850,224 SF FOOTPRINT  
 100,000 SF MEZ  
 TOTAL = 950,224 SF  
 1489.10 FF

- LEGEND**
- 12" STORM DRAIN
  - 18" STORM DRAIN
  - 24" STORM DRAIN
  - 36" STORM DRAIN
  - U/G STORAGE SYSTEM
  - BYPASS CHANNEL PER DETAIL
  - MODULAR WETLANDS UNIT
  - WET WELL/1 HP SUMP PUMP
  - 6" SEWER
  - 8" SEWER
  - 3" DOMESTIC WATER
  - 1.5" DOMESTIC WATER METER & BF
  - 10" FIRE WATER MAIN
  - 8" FIRE RISER LATERAL
  - 6" FIRE WATER LATERAL
  - FIRE HYDRANT

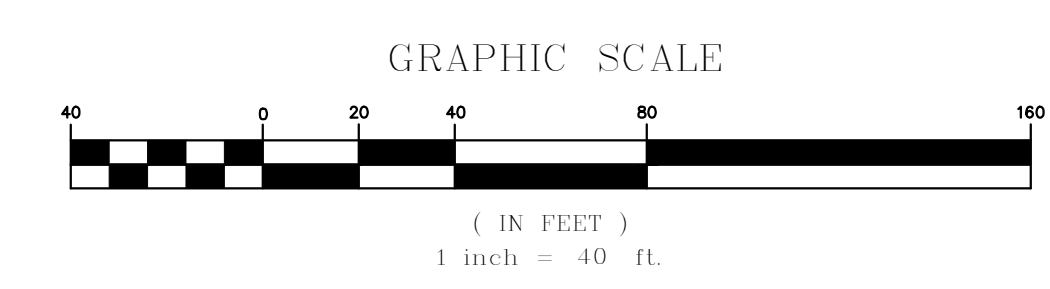

Sep 23 2022

DATE	BY	REVISION

PREPARED FOR:  
**PERRIS LANDCO, LLC**  
 201 SPEAR STREET #100  
 SAN FRANCISCO, CA 94105

PREPARED BY:  
**PBLA ENGINEERING, INC.**  
 Planning • Engineering • Surveying  
 1809 E. DYER ROAD, STE 301  
 SANTA ANA, CALIF. 92705  
 (888) 714-9642 • (714) 389-9191 FAX

TOPOGRAPHY DATE: 12-23-20

CITY OF PERRIS

**CONCEPT UTILITY PLAN**  
**INDUSTRIAL SITE**

**RAMONA GATEWAY COMMERCE CENTER**

WO 139-1  
 Sht. 6 of 7

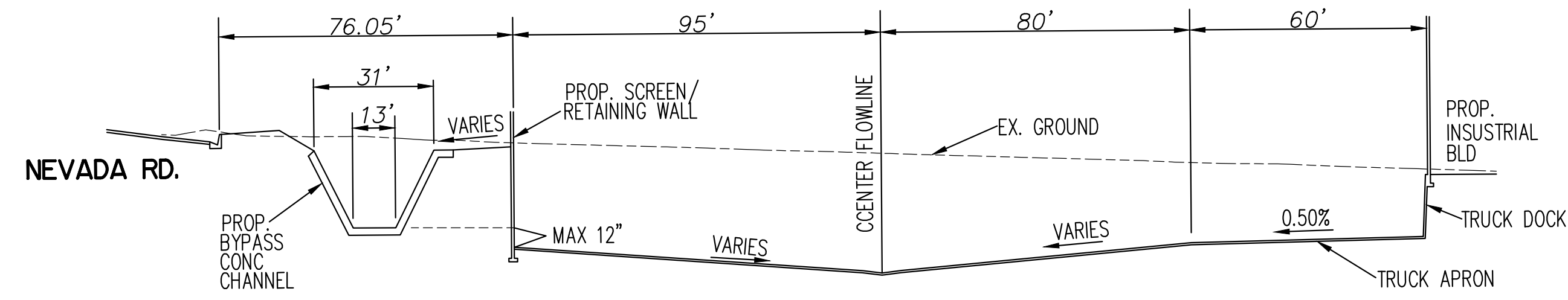

**SECTION A**

NTS SEE SHT 2

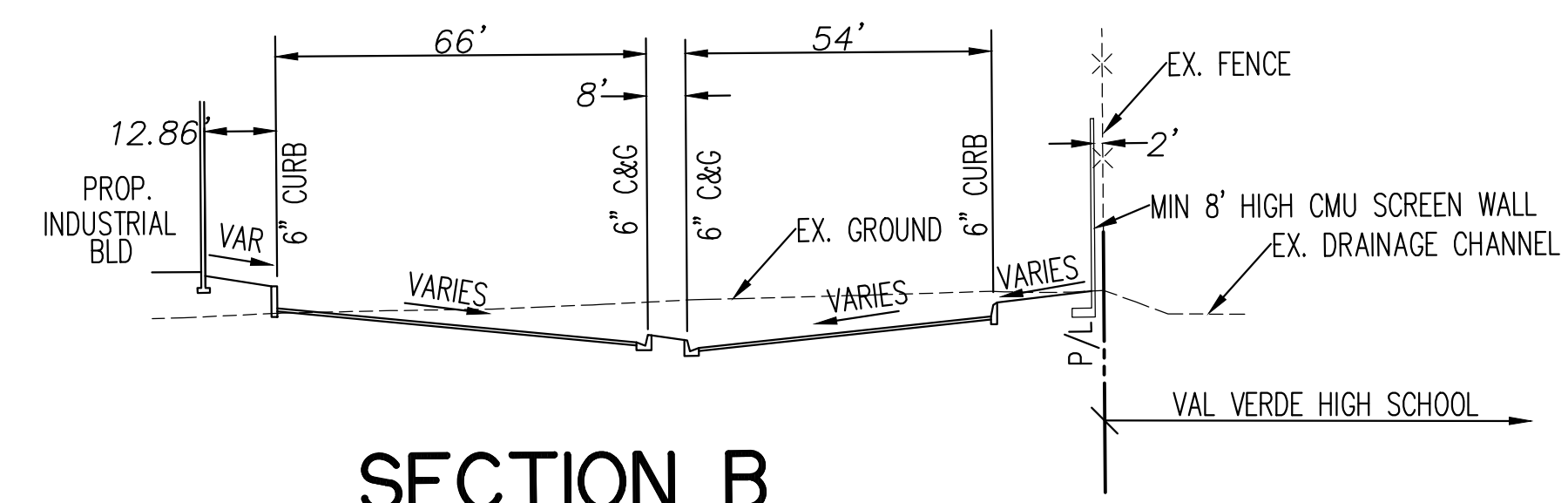

**SECTION B**

NTS SEE SHT 3

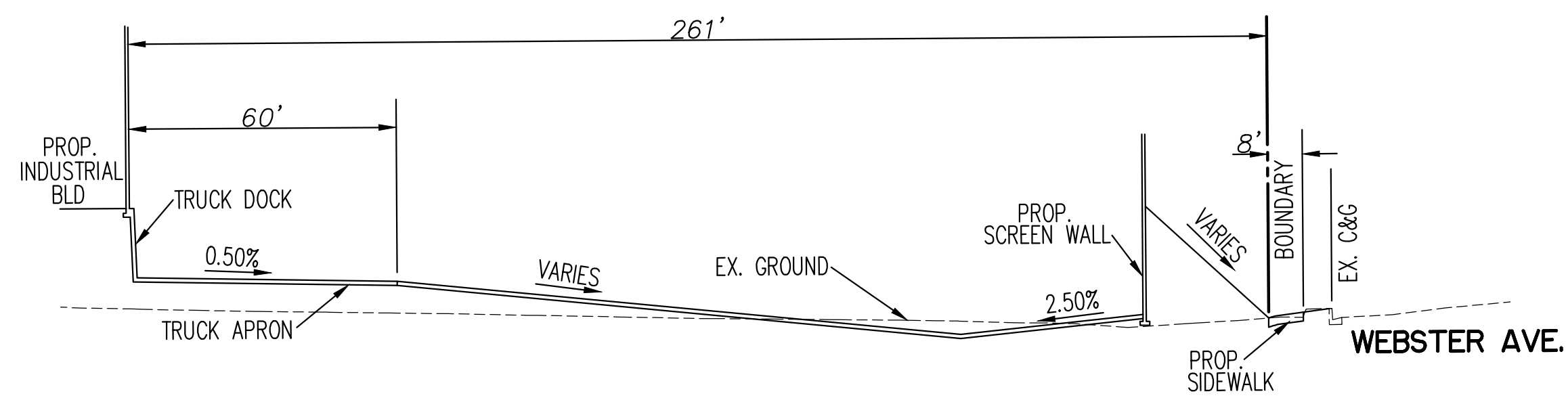

**SECTION C**

NTS SEE SHT 2

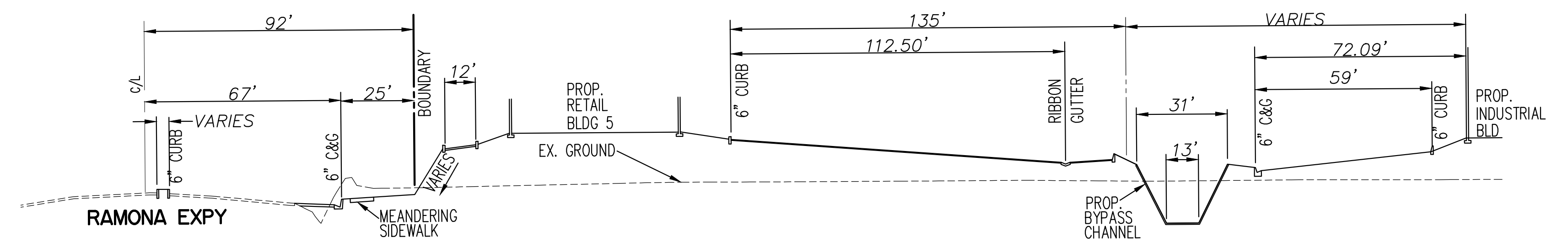

**SECTION D**

NTS SEE SHTS 1&2

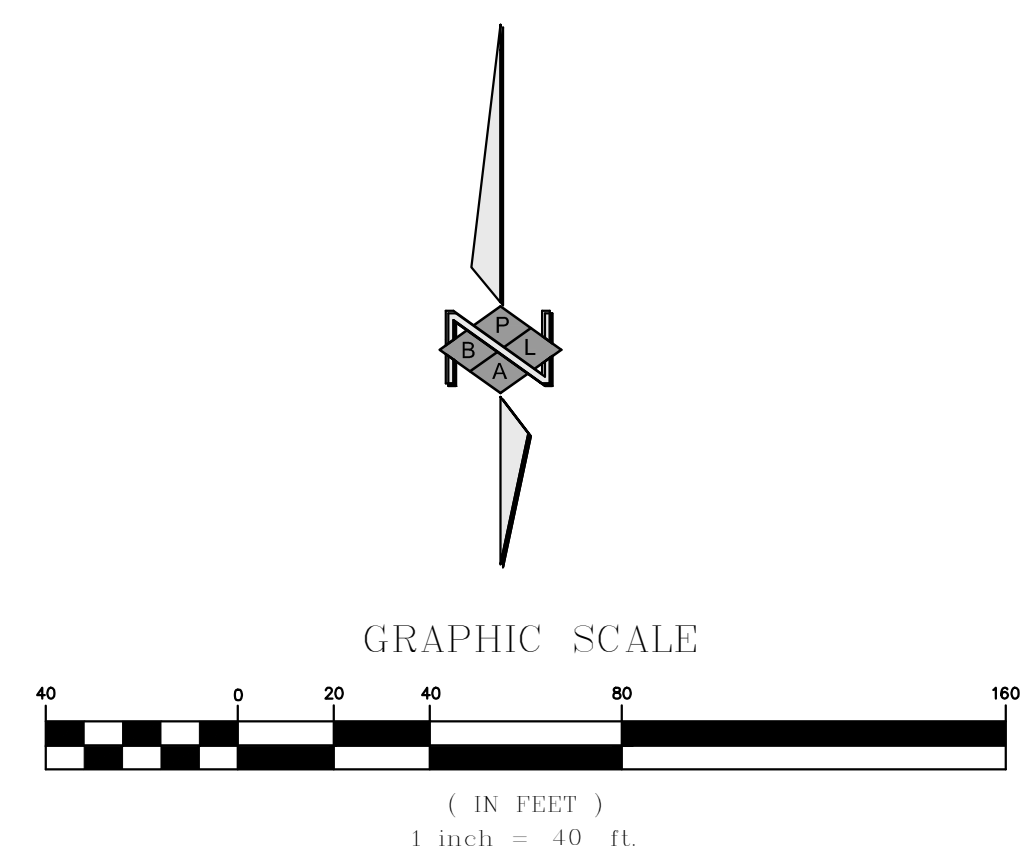

TOPOGRAPHY DATE: 12-23-20

Sep 23 2022

DATE	BY	REVISION

PREPARED FOR:  
**PERRIS LANDCO, LLC**  
201 SPEAR STREET #100  
SAN FRANCISCO, CA 94105

PREPARED BY:  
**PBLA ENGINEERING, INC.**  
Planning • Engineering • Surveying  
1809 E. DYER ROAD, STE 301  
SANTA ANA, CALIF. 92705  
(888) 714-9642 • (714)389-9191 FAX

CITY OF PERRIS  
**CONCEPT UTILITY PLAN**  
**CROSS SECTIONS**  
**RAMONA GATEWAY COMMERCE CENTER**

WO  
139-1  
Sht. 7 of 7

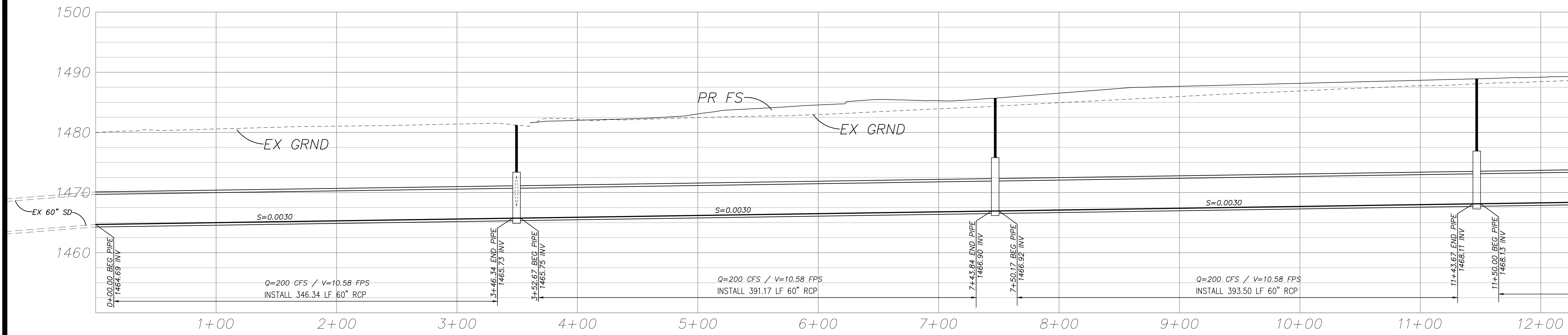

SEE BELOW LEFT

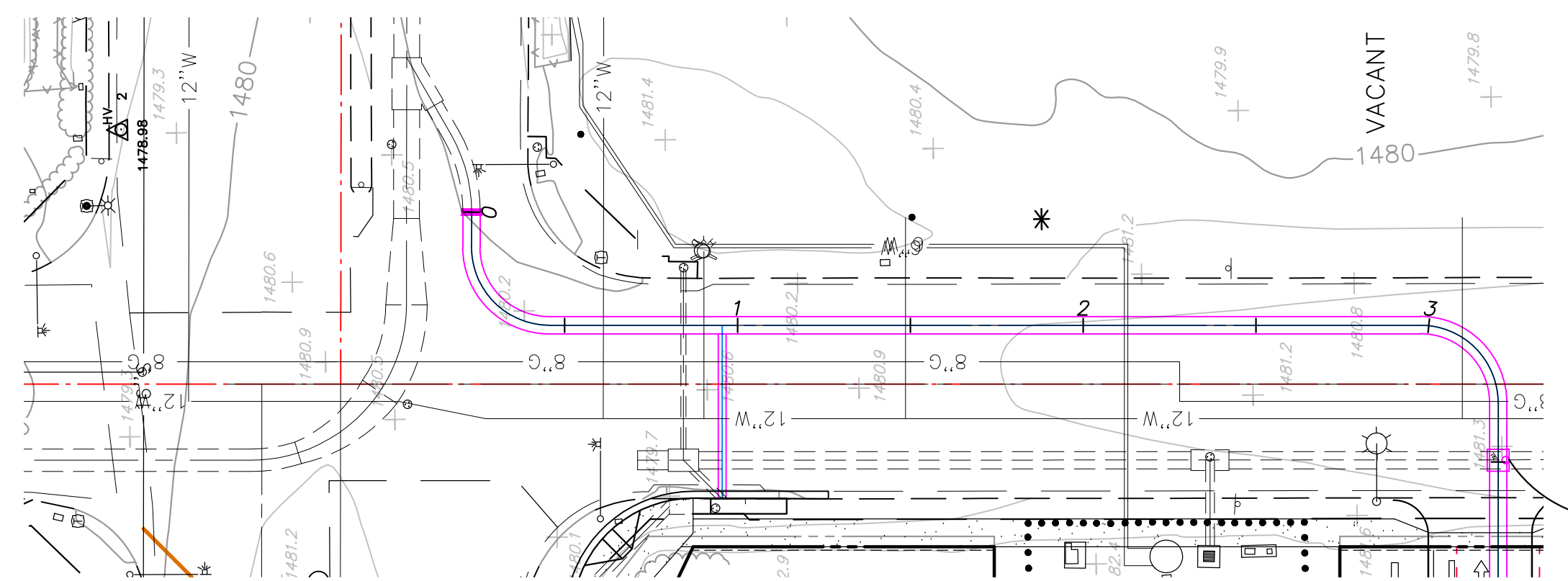

60" STORM DRAIN PLAN LINE 1

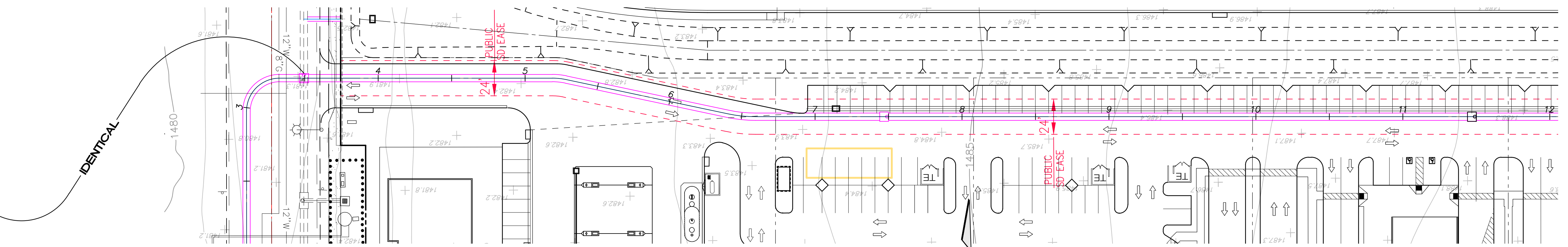

60" STORM DRAIN PLAN LINE 1

SEE BELOW LEFT

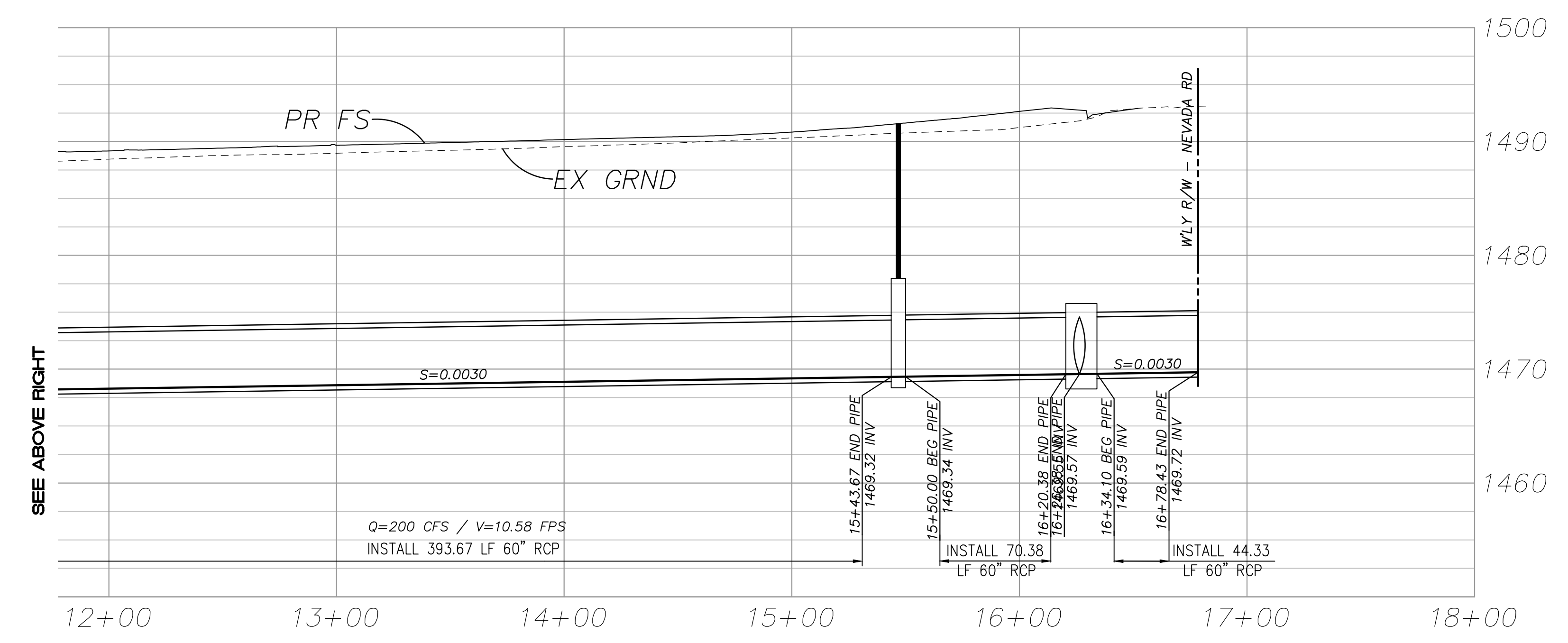

SEE ABOVE RIGHT

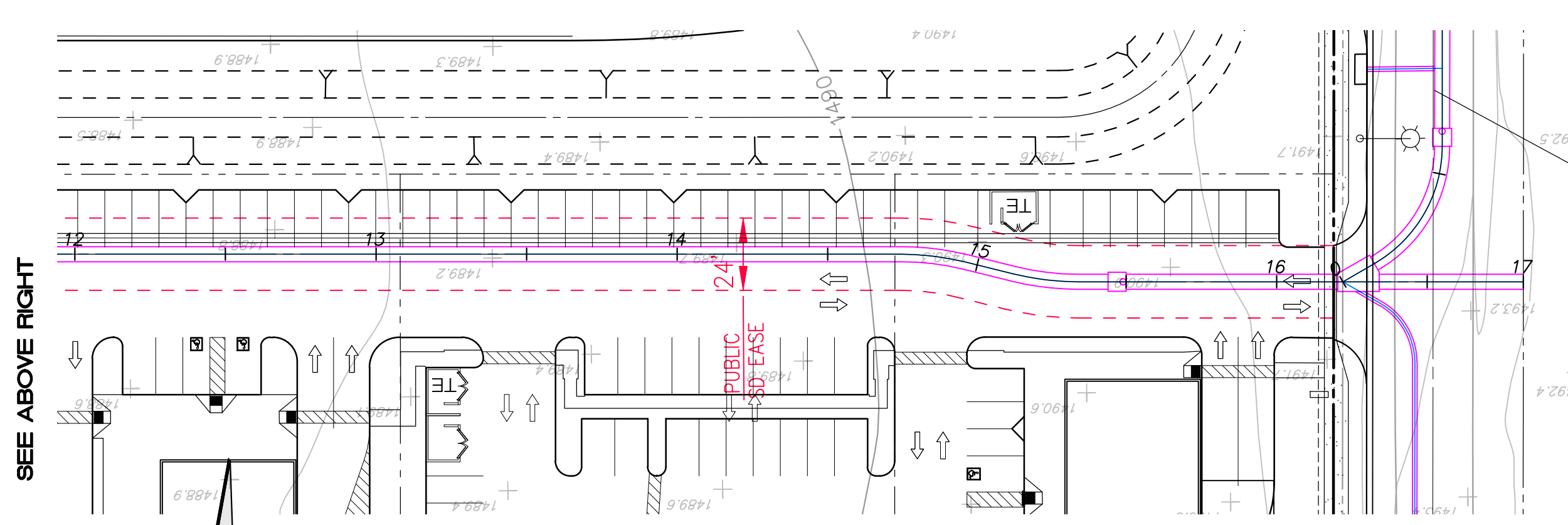

60" STORM DRAIN PLAN LINE 1

SEE SHEET 2 FOR LINE 2

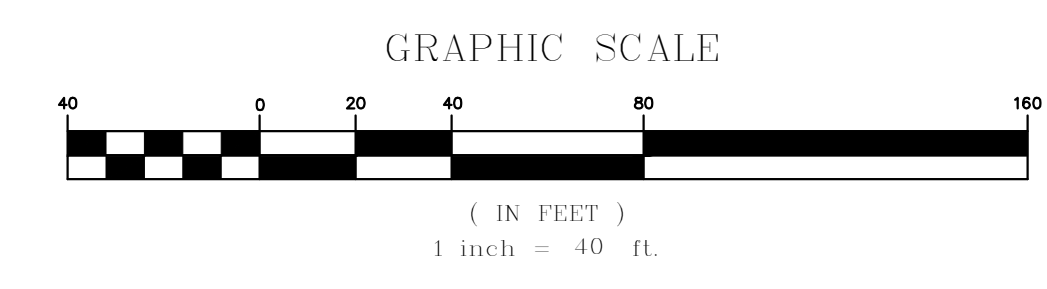

Sep 23 2022

DATE	BY	REVISION
4-15-21	SDL	1st Release

PREPARED FOR:  
**PERRIS LANDCO, LLC**  
 201 SPEAR STREET #100  
 SAN FRANCISCO, CA 94105

PREPARED BY:  

**PBLA ENGINEERING, INC.**  
 Planning • Engineering • Surveying  
 1809 E. DYER ROAD, STE 301  
 SANTA ANA, CALIF. 92705  
 (888) 714-9642 • (714) 389-9191 FAX

TOPOGRAPHY DATE: 12-23-20  
 CITY OF PERRIS  
**CONCEPT BYPASS PLAN  
 LINE 1**  
**RAMONA GATEWAY COMMERCE CENTER**

WO  
 139-1  
 Sht. 1 of 3

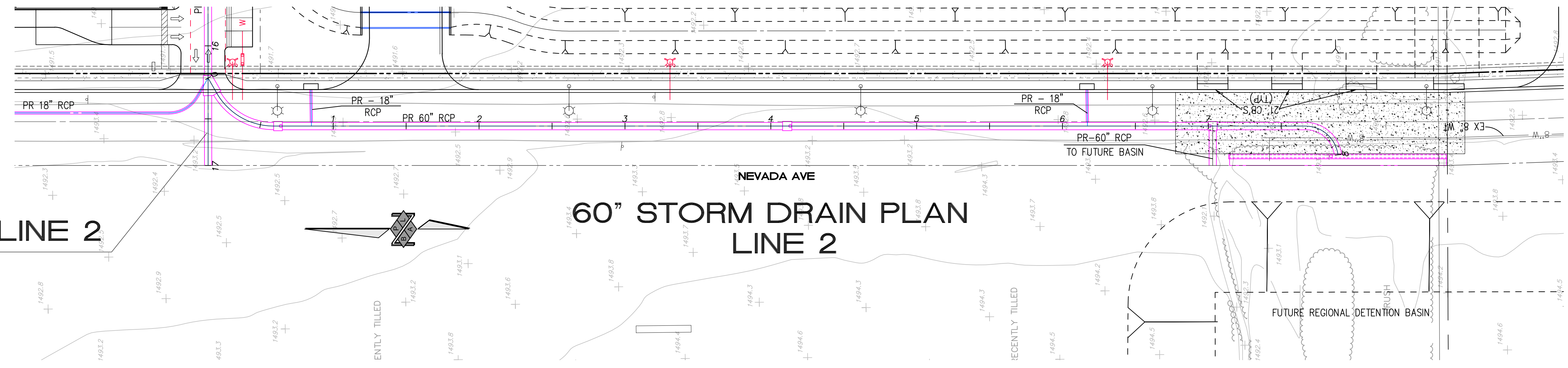
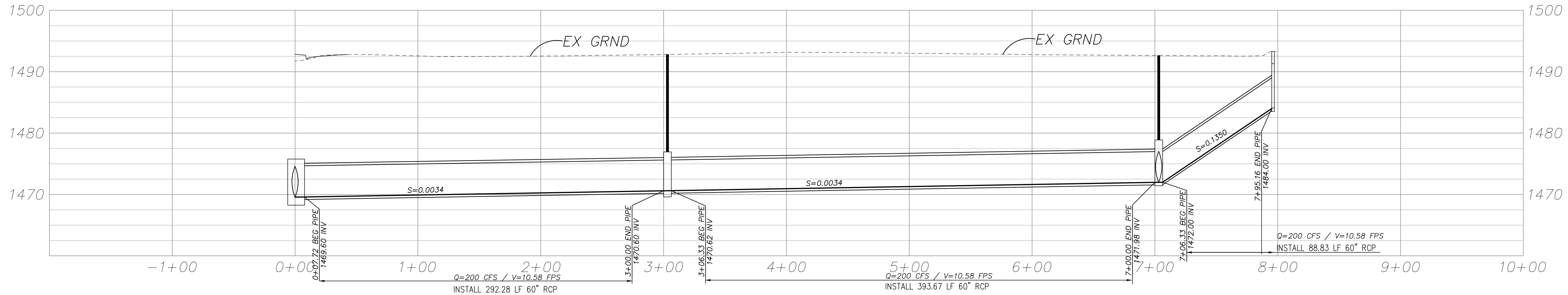

SEE SHEET 2 FOR LINE 2

**60" STORM DRAIN PLAN  
LINE 2**

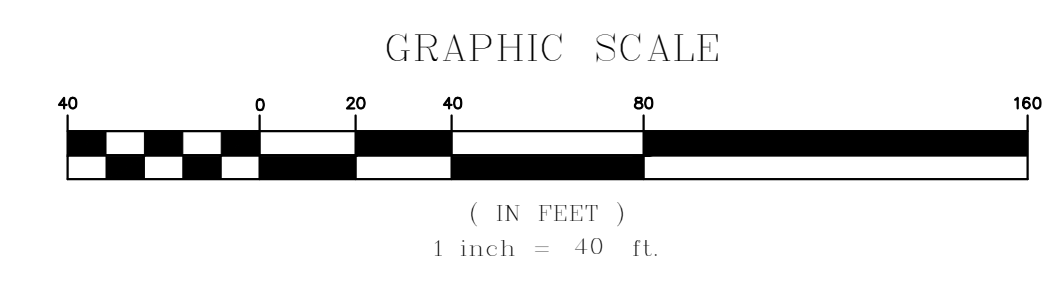

Sep 23 2022

DATE	BY	REVISION
4-15-21	SDL	1st Release

PREPARED FOR:  
**PERRIS LANDCO, LLC**  
201 SPEAR STREET #100  
SAN FRANCISCO, CA 94105

PREPARED BY:  
 **PBLA ENGINEERING, INC.**  
Planning • Engineering • Surveying  
1809 E. DYER ROAD, STE 301  
SANTA ANA, CALIF. 92705  
(888) 714-9642 • (714) 389-9191 FAX

TOPOGRAPHY DATE: 12-23-20  
CITY OF PERRIS  
**CONCEPT BYPASS PLAN  
LINE 2**  
**RAMONA GATEWAY COMMERCE CENTER**

WO  
139-1  
Sht. 2 of 3

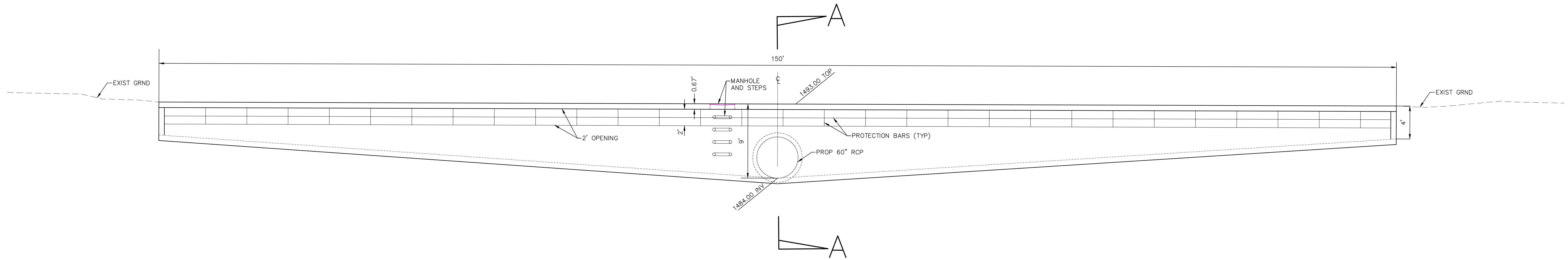

**INLET STRUCTURE DETAIL**

SCALE: 1" = 5'

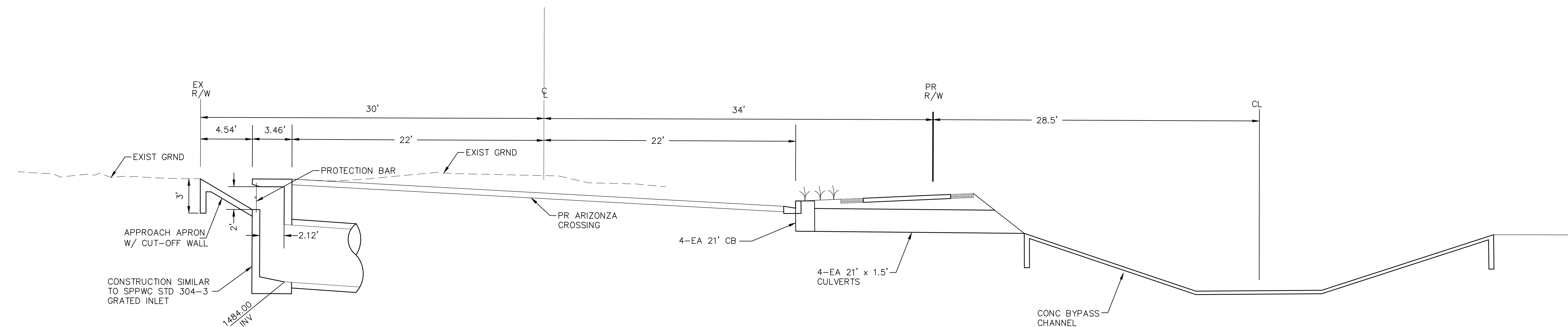

**SECTION A-A**

SCALE: 1" = 5'

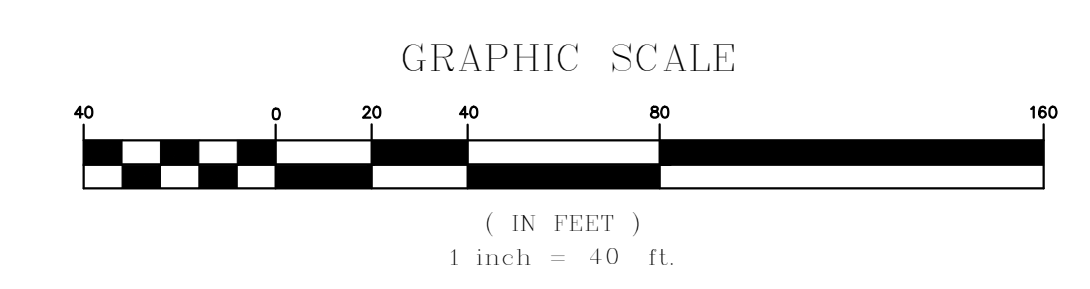

TOPOGRAPHY DATE: 12-23-20

Sep 23 2022

DATE	BY	REVISION
4-15-21	SDL	1st Release

PREPARED FOR:  
**PERRIS LANDCO, LLC**  
 201 SPEAR STREET #100  
 SAN FRANCISCO, CA 94105

PREPARED BY:  

**PBL ENGINEERING, INC.**  
 Planning • Engineering • Surveying  
 1809 E. DYER ROAD, STE 301  
 SANTA ANA, CALIF. 92705  
 (888) 714-9642 • (714) 389-9191 FAX

CITY OF PERRIS  
**CONCEPT BYPASS PLAN**  
**RAMONA GATEWAY COMMERCE CENTER**

WO  
 139-1  
 Sht. 3 of 3

# Appendix 3: Soils Information

*Geotechnical Study and Other Infiltration Testing Data*

PROVIDED IN FINAL REPORT

# Appendix 4: Historical Site Conditions

*Phase I Environmental Site Assessment or Other Information on Past Site Use*

PROVIDED IN FINAL REPORT

# Appendix 5: LID Infeasibility

*LID Technical Infeasibility Analysis*

Alternative Compliance due to low infiltration potential

# Appendix 6: BMP Design Details

*BMP Sizing, Design Details and other Supporting Documentation*

# Santa Ana Watershed - BMP Design Flow Rate, $Q_{BMP}$

(Rev. 10-2011)

Legend:

Required Entries

Calculated Cells

*(Note this worksheet shall **only** be used in conjunction with BMP designs from the **LID BMP Design Handbook**)*

Company Name **PBLA Engineering, Inc**

Date **9/13/2022**

Designed by **SDL**

Case No **P21-00013**

Company Project Number/Name

**RGCC - 139-1**

## BMP Identification

BMP NAME / ID **DMA-B**

*Must match Name/ID used on BMP Design Calculation Sheet*

## Design Rainfall Depth

Design Rainfall Intensity

I = **0.20** in/hr

## Drainage Management Area Tabulation

*Insert additional rows if needed to accommodate all DMAs draining to the BMP*

DMA Type/ID	DMA Area (square feet)	Post-Project Surface Type (use pull-down menu)	Effective Imperivous Fraction, $I_f$	DMA Runoff Factor	DMA Areas x Runoff Factor	Design Rainfall Intensity (in/hr)	Design Flow Rate (cfs)	Proposed Flow Rate (cfs)
DMA B	2400	Roofs	1	0.89	2140.8	0.20	0	0.1
DMA B	8359	Concrete or Asphalt	1	0.892	7456.2			
DMA B	1068	Ornamental Landscaping	0.1	0.110458	118			
<b>11827</b>		<b>Total</b>		<b>9715</b>	<b>0.20</b>			

Notes:

**Santa Ana Watershed - BMP Design Flow Rate,  $Q_{BMP}$**

(Rev. 10-2011)

Legend:

Required Entries

Calculated Cells

*(Note this worksheet shall **only** be used in conjunction with BMP designs from the **LID BMP Design Handbook**)*

Company Name **PBLA Engineering, Inc**

Date **9/13/2022**

Designed by **SDL**

Case No **P21-00013**

Company Project Number/Name **RGCC - 139-1**

**BMP Identification**

BMP NAME / ID **DMA-C**

*Must match Name/ID used on BMP Design Calculation Sheet*

**Design Rainfall Depth**

Design Rainfall Intensity

I = **0.20** in/hr

**Drainage Management Area Tabulation**

*Insert additional rows if needed to accommodate all DMAs draining to the BMP*

DMA Type/ID	DMA Area (square feet)	Post-Project Surface Type (use pull-down menu)	Effective Imperivous Fraction, $I_f$	DMA Runoff Factor	DMA Areas x Runoff Factor	Design Rainfall Intensity (in/hr)	Design Flow Rate (cfs)	Proposed Flow Rate (cfs)
DMA C	6000	Roofs	1	0.89	5352	0.20	0	0.1
DMA C	5778	Concrete or Asphalt	1	0.892	5154			
DMA C	1915	Ornamental Landscaping	0.1	0.110458	211.5			
<b>13693</b>		<b>Total</b>		<b>10717.5</b>	<b>0.20</b>			

Notes:

# Santa Ana Watershed - BMP Design Flow Rate, $Q_{BMP}$

(Rev. 10-2011)

Legend:

Required Entries

Calculated Cells

*(Note this worksheet shall **only** be used in conjunction with BMP designs from the **LID BMP Design Handbook**)*

Company Name **PBLA Engineering, Inc**

Date **9/13/2022**

Designed by **SDL**

Case No **P21-00013**

Company Project Number/Name **RGCC - 139-1**

## BMP Identification

BMP NAME / ID **DMA-D**

*Must match Name/ID used on BMP Design Calculation Sheet*

## Design Rainfall Depth

Design Rainfall Intensity

I = **0.20** in/hr

## Drainage Management Area Tabulation

*Insert additional rows if needed to accommodate all DMAs draining to the BMP*

DMA Type/ID	DMA Area (square feet)	Post-Project Surface Type (use pull-down menu)	Effective Imperivous Fraction, $I_f$	DMA Runoff Factor	DMA Areas x Runoff Factor	Design Rainfall Intensity (in/hr)	Design Flow Rate (cfs)	Proposed Flow Rate (cfs)
DMA D	0	Roofs	1	0.89	0	0.20	0.1	0.1
DMA D	11697	Concrete or Asphalt	1	0.892	10433.7			
DMA D	5182	Ornamental Landscaping	0.1	0.110458	572.4			
<b>16879</b>		<b>Total</b>		<b>11006.1</b>	<b>0.20</b>			

Notes:

# Santa Ana Watershed - BMP Design Flow Rate, $Q_{BMP}$

(Rev. 10-2011)

Legend:

Required Entries

Calculated Cells

*(Note this worksheet shall **only** be used in conjunction with BMP designs from the **LID BMP Design Handbook**)*

Company Name **PBLA Engineering, Inc**

Date **9/13/2022**

Designed by **SDL**

Case No **P21-00013**

Company Project Number/Name

**RGCC - 139-1**

## BMP Identification

BMP NAME / ID **DMA-E**

*Must match Name/ID used on BMP Design Calculation Sheet*

## Design Rainfall Depth

Design Rainfall Intensity

I = **0.20** in/hr

## Drainage Management Area Tabulation

*Insert additional rows if needed to accommodate all DMAs draining to the BMP*

DMA Type/ID	DMA Area (square feet)	Post-Project Surface Type (use pull-down menu)	Effective Imperivous Fraction, $I_f$	DMA Runoff Factor	DMA Areas x Runoff Factor	Design Rainfall Intensity (in/hr)	Design Flow Rate (cfs)	Proposed Flow Rate (cfs)
DMA E	4500	Roofs	1	0.89	4014	0.20	0.1	0.1
DMA E	11540	Concrete or Asphalt	1	0.892	10293.7			
DMA E	2619	Ornamental Landscaping	0.1	0.110458	289.3			
<b>18659</b>		<b>Total</b>		<b>14597</b>	<b>0.20</b>			

Notes:

**Santa Ana Watershed - BMP Design Flow Rate,  $Q_{BMP}$**

(Rev. 10-2011)

Legend:

Required Entries

Calculated Cells

*(Note this worksheet shall **only** be used in conjunction with BMP designs from the **LID BMP Design Handbook**)*

Company Name **PBLA Engineering, Inc**

Date **9/13/2022**

Designed by **SDL**

Case No **P21-00013**

Company Project Number/Name

**RGCC - 139-1**

**BMP Identification**

BMP NAME / ID **DMA-F**

*Must match Name/ID used on BMP Design Calculation Sheet*

**Design Rainfall Depth**

Design Rainfall Intensity

I = **0.20** in/hr

**Drainage Management Area Tabulation**

*Insert additional rows if needed to accommodate all DMAs draining to the BMP*

DMA Type/ID	DMA Area (square feet)	Post-Project Surface Type (use pull-down menu)	Effective Imperivous Fraction, $I_f$	DMA Runoff Factor	DMA Areas x Runoff Factor	Design Rainfall Intensity (in/hr)	Design Flow Rate (cfs)	Proposed Flow Rate (cfs)
DMA F	4500	Roofs	1	0.89	4014	0.20	0.1	0.1
DMA F	11607	Concrete or Asphalt	1	0.892	10353.4			
DMA F	3567	Ornamental Landscaping	0.1	0.110458	394			
<b>19674</b>		<b>Total</b>		<b>14761.4</b>	<b>0.20</b>			

Notes:

# Santa Ana Watershed - BMP Design Flow Rate, $Q_{BMP}$

(Rev. 10-2011)

Legend:

Required Entries

Calculated Cells

*(Note this worksheet shall **only** be used in conjunction with BMP designs from the **LID BMP Design Handbook**)*

Company Name **PBLA Engineering, Inc**

Date **9/13/2022**

Designed by **SDL**

Case No **P21-00013**

Company Project Number/Name

**RGCC - 139-1**

## BMP Identification

BMP NAME / ID **DMA-G**

*Must match Name/ID used on BMP Design Calculation Sheet*

## Design Rainfall Depth

Design Rainfall Intensity

I = **0.20** in/hr

## Drainage Management Area Tabulation

*Insert additional rows if needed to accommodate all DMAs draining to the BMP*

DMA Type/ID	DMA Area (square feet)	Post-Project Surface Type (use pull-down menu)	Effective Imperivous Fraction, $I_f$	DMA Runoff Factor	DMA Areas x Runoff Factor	Design Rainfall Intensity (in/hr)	Design Flow Rate (cfs)	Proposed Flow Rate (cfs)
DMA G	5500	Roofs	1	0.89	4906	0.20	0	0.1
DMA G	6085	Concrete or Asphalt	1	0.892	5427.8			
DMA G	3290	Ornamental Landscaping	0.1	0.110458	363.4			
<b>14875</b>		<b>Total</b>		<b>10697.2</b>				

Notes:

# Santa Ana Watershed - BMP Design Flow Rate, $Q_{BMP}$

(Rev. 10-2011)

Legend:

Required Entries

Calculated Cells

*(Note this worksheet shall **only** be used in conjunction with BMP designs from the **LID BMP Design Handbook**)*

Company Name **PBLA Engineering, Inc**

Date **9/13/2022**

Designed by **SDL**

Case No **P21-00013**

Company Project Number/Name

**RGCC - 139-1**

## BMP Identification

BMP NAME / ID **DMA-H**

*Must match Name/ID used on BMP Design Calculation Sheet*

## Design Rainfall Depth

Design Rainfall Intensity

I = **0.20** in/hr

## Drainage Management Area Tabulation

*Insert additional rows if needed to accommodate all DMAs draining to the BMP*

DMA Type/ID	DMA Area (square feet)	Post-Project Surface Type (use pull-down menu)	Effective Imperivous Fraction, $I_f$	DMA Runoff Factor	DMA Areas x Runoff Factor	Design Rainfall Intensity (in/hr)	Design Flow Rate (cfs)	Proposed Flow Rate (cfs)
DMA H	4500	Roofs	1	0.89	4014	0.20	0.1	0.1
DMA H	8904	Concrete or Asphalt	1	0.892	7942.4			
DMA H	9080	Ornamental Landscaping	0.1	0.110458	1003			
<b>22484</b>		<b>Total</b>		<b>12959.4</b>	<b>0.20</b>	<b>0.1</b>	<b>0.1</b>	

Notes:

# Santa Ana Watershed - BMP Design Flow Rate, $Q_{BMP}$

(Rev. 10-2011)

Legend:

Required Entries

Calculated Cells

*(Note this worksheet shall **only** be used in conjunction with BMP designs from the **LID BMP Design Handbook**)*

Company Name **PBLA Engineering, Inc**

Date **9/13/2022**

Designed by **SDL**

Case No **P21-00013**

Company Project Number/Name

**RGCC - 139-1**

## BMP Identification

BMP NAME / ID **DMA-L**

*Must match Name/ID used on BMP Design Calculation Sheet*

## Design Rainfall Depth

Design Rainfall Intensity

I = **0.20** in/hr

## Drainage Management Area Tabulation

*Insert additional rows if needed to accommodate all DMAs draining to the BMP*

DMA Type/ID	DMA Area (square feet)	Post-Project Surface Type (use pull-down menu)	Effective Imperivous Fraction, $I_f$	DMA Runoff Factor	DMA Areas x Runoff Factor	Design Rainfall Intensity (in/hr)	Design Flow Rate (cfs)	Proposed Flow Rate (cfs)
DMA L	0	Roofs	1	0.89	0	0.20	0	0.1
DMA L	8441	Concrete or Asphalt	1	0.892	7529.4			
DMA L	4226	Ornamental Landscaping	0.1	0.110458	466.8			
<b>12667</b>		<b>Total</b>		<b>7996.2</b>	<b>0.20</b>			

Notes:

**Santa Ana Watershed - BMP Design Volume,  $V_{BMP}$**

(Rev. 10-2011)

Legend:

Required Entries

Calculated Cells

*(Note this worksheet shall **only** be used in conjunction with BMP designs from the **LID BMP Design Handbook**)*

Company Name **PBLA ENGINEERING, INC**

Date **9/13/2022**

Designed by **SDL**

Case No **P21-00013**

Company Project Number/Name **R & W - PERRIS**

**BMP Identification**

BMP NAME / ID **DMA - I - DRIVE AISLE & PARKING**

*Must match Name/ID used on BMP Design Calculation Sheet*

**Design Rainfall Depth**

85th Percentile, 24-hour Rainfall Depth,  
from the Isohyetal Map in Handbook Appendix E

$D_{85}$  = **0.58** inches

**Drainage Management Area Tabulation**

*Insert additional rows if needed to accommodate all DMAs draining to the BMP*

DMA Type/ID	DMA Area (square feet)	Post-Project Surface Type	Effective Imperivous Fraction, $I_f$	DMA Runoff Factor	DMA Areas x Runoff Factor	Design Storm Depth (in)	Design Capture Volume, $V_{BMP}$ (cubic feet)	Proposed Volume on Plans (cubic feet)
<i>I</i>	<i>0</i>	<i>Roofs</i>	<i>1</i>	<i>0.89</i>	<i>0</i>			
<i>I</i>	<i>88,577</i>	<i>Concrete or Asphalt</i>	<i>1</i>	<i>0.89</i>	<i>79010.7</i>			
<i>I</i>	<i>8,966</i>	<i>Ornamental Landscaping</i>	<i>0.1</i>	<i>0.11</i>	<i>990.4</i>			
	<b>97543</b>	<b>Total</b>			<b>80001.1</b>	<b>0.58</b>	<b>3866.7</b>	<b>5,000</b>

**#REF!**

Notes:

**Santa Ana Watershed - BMP Design Volume,  $V_{BMP}$**

(Rev. 10-2011)

Legend:

Required Entries

Calculated Cells

*(Note this worksheet shall **only** be used in conjunction with BMP designs from the **LID BMP Design Handbook**)*

Company Name **PBLA ENGINEERING, INC**

Date **9/13/2022**

Designed by **SDL**

Case No **P21-00013**

Company Project Number/Name **R & W - PERRIS**

**BMP Identification**

BMP NAME / ID **DMA - J WEST SIDE INDUSTRIAL**

*Must match Name/ID used on BMP Design Calculation Sheet*

**Design Rainfall Depth**

85th Percentile, 24-hour Rainfall Depth,  
from the Isohyetal Map in Handbook Appendix E

$D_{85} =$  **0.58** inches

**Drainage Management Area Tabulation**

*Insert additional rows if needed to accommodate all DMAs draining to the BMP*

DMA Type/ID	DMA Area (square feet)	Post-Project Surface Type	Effective Imperivous Fraction, $I_f$	DMA Runoff Factor	DMA Areas x Runoff Factor	Design Storm Depth (in)	Design Capture Volume, $V_{BMP}$ (cubic feet)	Proposed Volume on Plans (cubic feet)
J	438,446	Roofs	1	0.89	391093.8			
J	88,577	Concrete or Asphalt	1	0.89	79010.7			
J	8,966	Ornamental Landscaping	0.1	0.11	990.4			
	<b>535989</b>				<b>471094.9</b>	<b>0.58</b>	<b>22769.6</b>	<b>37997</b>

**#REF!**

Notes:

**Santa Ana Watershed - BMP Design Volume,  $V_{BMP}$**

(Rev. 10-2011)

Legend:

Required Entries

Calculated Cells

*(Note this worksheet shall **only** be used in conjunction with BMP designs from the **LID BMP Design Handbook**)*

Company Name **PBLA ENGINEERING, INC**

Date **9/13/2022**

Designed by **SDL**

Case No **P21-00013**

Company Project Number/Name **R & W - PERRIS**

**BMP Identification**

BMP NAME / ID **DMA - K EAST SIDE INDUSTRIAL**

*Must match Name/ID used on BMP Design Calculation Sheet*

**Design Rainfall Depth**

85th Percentile, 24-hour Rainfall Depth,  
from the Isohyetal Map in Handbook Appendix E

$D_{85}$  = **0.58** inches

**Drainage Management Area Tabulation**

*Insert additional rows if needed to accommodate all DMAs draining to the BMP*

DMA Type/ID	DMA Area (square feet)	Post-Project Surface Type	Effective Imperivous Fraction, $I_f$	DMA Runoff Factor	DMA Areas x Runoff Factor	Design Storm Depth (in)	Design Capture Volume, $V_{BMP}$ (cubic feet)	Proposed Volume on Plans (cubic feet)
K	419,494	Roofs	1	0.89	374188.6			
K	88,577	Concrete or Asphalt	1	0.89	79010.7			
K	8,966	Ornamental Landscaping	0.1	0.11	990.4			
	<b>517037</b>				<b>454189.7</b>	<b>0.58</b>	<b>21952.5</b>	<b>37211</b>

**#REF!**

Notes:

# ADS® Barracuda™ Max

The Barracuda Max is market-changing stormwater quality technology. This high-performance vortex hydrodynamic separator is designed to remove total suspended solids in order to protect our precious receiving waters. The Barracuda Max is also an outstanding value that offers multiple pipe configurations, and quick installation. The “Max” version of the Barracuda is built on the base platform of the original ADS Barracuda with improved removal efficiencies and installation components.

## Features

- Single manhole design
- No elevation loss between the inlet and outlet
- Variable inlet/outlet angle configurations (not just 180 degree orientation)
- Internal bypass for inline installation (where applicable)
- Revolutionary, patent-pending “teeth” mitigate turbulence in the sump area to prevent re-suspension of captured contaminants and an added deflector plate and bowl extension enhance the unit’s removal capabilities

## Benefits

- Internal components are in stock for quick delivery
- The S3, S4, S6, and S8 can be installed in a standard 36” (900 mm), 48” (1200 m), 72” (1800 m), and 96” (2400 m) precast manhole, respectively
- The S3 & S4 can be provided factory installed within a 36” (900 mm) and 48” (1200 mm) ADS HP manhole and delivered to the jobsite
- The Barracuda Max “teeth” and deflector plate apparatus are fabricated and designed for quick and easy field assembly
- Designed for easy maintenance using a vacuum truck or similar equipment.
- Inspection and maintenance are performed from the surface with no confined space entry

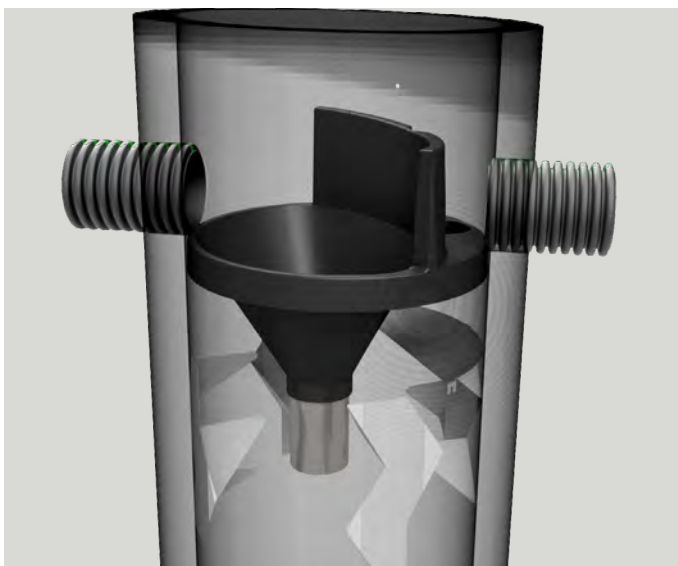

# Barrucuda Specification

## Materials and Design

- Concrete Structures: Designed for H-20 traffic loading and applicable soil loads or as otherwise determined by a Licensed Professional Engineer. The materials and structural design of the devices shall be per ASTM C857 and ASTM C858.
- 36" (900 mm) and 48" (1200 mm) HP Manhole Structures: Made from an impact modified copolymer polypropylene meeting the material requirements of ASTM F2764. The eccentric cone reducer shall be manufactured from polyethylene material meeting ASTM D3350 cell class 213320C. Gaskets shall be made of material meeting the requirements of ASTM F477.
- Separator internals shall be substantially constructed of stainless steel, polyethylene or other thermoplastic material approved by the manufacturer.

## Performance

- The stormwater treatment unit shall be an inline unit capable of conveying 100% of the design peak flow. If peak flow rates exceed maximum hydraulic rate, the unit shall be installed offline.
- The Barracuda Max unit shall be designed to remove at least 80% of the suspended solids on an annual aggregate removal basis. Said removal shall be based on full-scale third party testing using OK-110 media gradation or equivalent and 300 mg/L influent concentration. Said full scale testing shall have included sediment capture based on actual total mass collected by the stormwater treatment unit.

- OR -

The Barracuda Max unit shall be designed to remove at least 50% of TSS using a media mix with  $d_{50}$ =75 micron and 200 mg/L influent concentration.

- OR -

The Barracuda Max unit shall be designed to remove at least 50% of TSS per current NJDEP/NJCAT HDS protocol.

- The stormwater treatment unit internals shall consist of (1) separator cone assembly, and (1) sump assembly, which includes the "teeth".

Barracuda Max Model	Manhole Diameter	NJDEP (50% removal)	OK-110 (80% removal)
S3	36" (900 mm)	0.85 CFS (24.1 L/s)	0.86 CFS (24.1 L/s)
S4	48" (1200 mm)	1.52 CFS (43.0 L/s)	1.52 CFS (43.0 L/s)
S6	72" (1800 mm)	3.40 CFS (96.3 L/s)	3.42 CFS (96.8 L/s)
S8	96" (2400 mm)	6.08 CFS (172.2 L/s)	6.08 CFS (172.2 L/s)

\* Peak bypass flows are dependent on final design

## Installation

Installation of the stormwater treatment unit(s) shall be performed per manufacturer's installation instructions. Such instructions can be obtained by calling Advanced Drainage Systems at 800-821-6710 or by logging on to [www.adspipe.com](http://www.adspipe.com).



## Modular Wetlands<sup>®</sup> Linear Operation & Maintenance Manual



## Maintenance Summary

- Remove Trash from Screening Device – average maintenance interval is 6 to 12 months.
  - (5 minute average service time ).
- Remove Sediment from Separation Chamber – average maintenance interval is 12 to 24 months.
  - (10 minute average service time ).
- Replace Cartridge Filter Media – average maintenance interval 12 to 24 months.
  - (10-15 minute per cartridge average service time ).
- Replace Drain Down Filter Media – average maintenance interval is 12 to 24 months.
  - (5 minute average service time ).
- Trim Vegetation – average maintenance interval is 6 to 12 months.
  - (Service time varies).

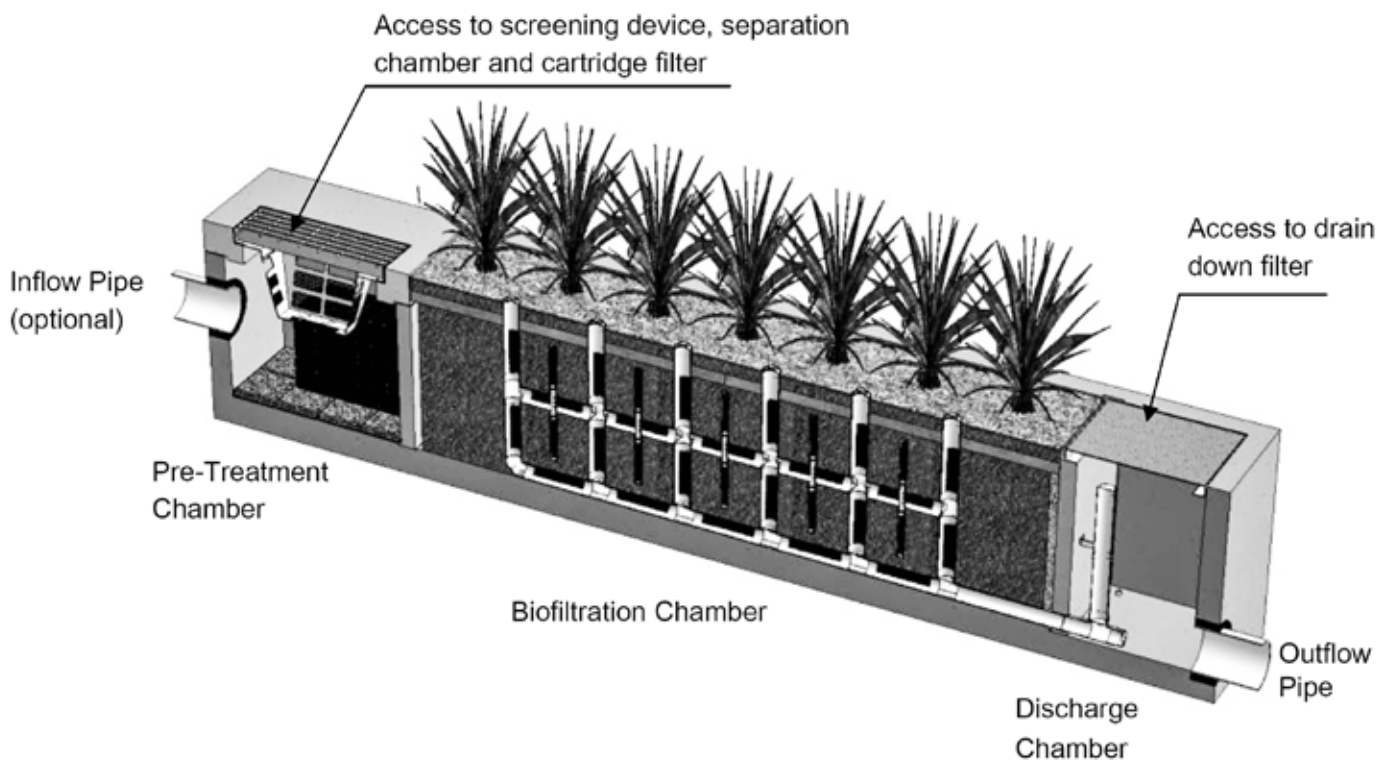

*System Diagram*

## **Maintenance Procedures**

### ***Screening Device***

1. Remove grate or manhole cover to gain access to the screening device in the Pre- Treatment Chamber. Vault type units do not have screening device. Maintenance can be performed without entry.
2. Remove all pollutants collected by the screening device. Removal can be done manually or with the use of a vacuum truck.
3. Screening device can easily be removed from the Pre-Treatment Chamber to gain access to separation chamber and media filters below. Replace grate or manhole cover when completed.

### ***Separation Chamber***

1. Perform maintenance procedures of screening device listed above before maintaining the separation chamber.
2. With a pressure washer, spray down pollutants accumulated on walls and cartridge filters.
3. Vacuum out Separation Chamber and remove all accumulated pollutants. Replace screening device, grate or manhole cover when completed.

### ***Cartridge Filters***

1. Perform maintenance procedures on screening device and separation chamber before maintaining cartridge filters.
2. Enter separation chamber.
3. Unscrew the two bolts holding the lid on each cartridge filter and remove lid.
4. Remove each of 4 to 8 media cages holding the media in place.
5. Spray down the cartridge filter to remove any accumulated pollutants.
6. Vacuum out old media and accumulated pollutants.
7. Reinstall media cages and fill with new media from manufacturer or outside supplier. Manufacturer will provide specification of media and sources to purchase.
8. Replace the lid and tighten down bolts. Replace screening device, grate or manhole cover when completed.

### ***Drain Down Filter***

1. Remove hatch or manhole cover over discharge chamber and enter chamber. Entry into chambers may require confined space training based on state and local regulations.
2. Unlock and lift drain down filter housing and remove old media block. Replace with new media block. Lower drain down filter housing and lock into place.
3. Exit chamber and replace hatch or manhole cover.

## Maintenance Notes

1. Following maintenance and/or inspection, it is recommended the maintenance operator prepare a maintenance/inspection record. The record should include any maintenance activities performed, amount and description of debris collected, and condition of the system and its various filter mechanisms.
2. The owner should keep maintenance/inspection record(s) for a minimum of five years from the date of maintenance. These records should be made available to the governing municipality for inspection upon request at any time.
3. Transport all debris, trash, organics and sediments to approved facility for disposal in accordance with local and state requirements.
4. Entry into chambers may require confined space training based on state and local regulations.
5. No fertilizer shall be used in the Biofiltration Chamber.
6. Irrigation should be provided as recommended by manufacturer and/or landscape architect. Amount of irrigation required is dependent on plant species. Some plants may require irrigation.

## Maintenance Procedure Illustration

### **Screening Device**

*The screening device is located directly under the manhole or grate over the Pre-Treatment Chamber. It's mounted directly underneath for easy access and cleaning. Device can be cleaned by hand or with a vacuum truck.*



### **Separation Chamber**

*The separation chamber is located directly beneath the screening device. It can be quickly cleaned using a vacuum truck or by hand. A pressure washer is useful to assist in the cleaning process.*

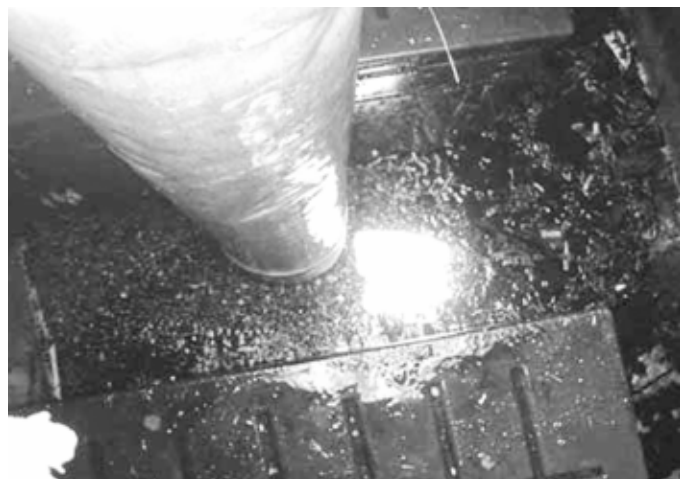

### **Cartridge Filters**

The cartridge filters are located in the Pre-Treatment chamber connected to the wall adjacent to the biofiltration chamber. The cartridges have removable tops to access the individual media filters. Once the cartridge is open media can be easily removed and replaced by hand or a vacuum truck.



### **Drain Down Filter**

The drain down filter is located in the Discharge Chamber. The drain filter unlocks from the wall mount and hinges up. Remove filter block and replace with new block.



### **Trim Vegetation**

Vegetation should be maintained in the same manner as surrounding vegetation and trimmed as needed. No fertilizer shall be used on the plants. Irrigation per the recommendation of the manufacturer and or landscape architect. Different types of vegetation requires different amounts of irrigation.





## Inspection Report Modular Wetlands Linear

Project Name \_\_\_\_\_

For Office Use Only
(Reviewed By) _____
(Date) _____ Office personnel to complete section to the left.

Project Address \_\_\_\_\_ (city) (Zip Code)

Owner / Management Company \_\_\_\_\_

Contact \_\_\_\_\_ Phone ( ) - \_\_\_\_\_

Inspector Name \_\_\_\_\_ Date \_\_\_\_ / \_\_\_\_ / \_\_\_\_\_ Time \_\_\_\_\_ AM / PM

Type of Inspection  Routine  Follow Up  Complaint  Storm Storm Event in Last 72-hours?  No  Yes

Weather Condition \_\_\_\_\_ Additional Notes \_\_\_\_\_

### Inspection Checklist

Modular Wetland System Type (Curb, Grate or UG Vault): \_\_\_\_\_ Size (22', 14' or etc.): \_\_\_\_\_

Structural Integrity:	Yes	No	Comments
Damage to pre-treatment access cover (manhole cover/grate) or cannot be opened using normal lifting pressure?			
Damage to discharge chamber access cover (manhole cover/grate) or cannot be opened using normal lifting pressure?			
Does the MWS unit show signs of structural deterioration (cracks in the wall, damage to frame)?			
Is the inlet/outlet pipe or drain down pipe damaged or otherwise not functioning properly?			
<b>Working Condition:</b>			
Is there evidence of illicit discharge or excessive oil, grease, or other automobile fluids entering and clogging the unit?			
Is there standing water in inappropriate areas after a dry period?			
Is the filter insert (if applicable) at capacity and/or is there an accumulation of debris/trash on the shelf system?			
Does the depth of sediment/trash/debris suggest a blockage of the inflow pipe, bypass or cartridge filter? If yes specify which one in the comments section. Note depth of accumulation in in pre-treatment chamber.			Depth:
Does the cartridge filter media need replacement in pre-treatment chamber and/or discharge chamber?			Chamber:
Any signs of improper functioning in the discharge chamber? Note issues in comments section.			
<b>Other Inspection Items:</b>			
Is there an accumulation of sediment/trash/debris in the wetland media (if applicable)?			
Is it evident that the plants are alive and healthy (if applicable)? Please note Plant Information below.			
Is there a septic or foul odor coming from inside the system?			

Waste:	Yes	No
Sediment / Silt / Clay		
Trash / Bags / Bottles		
Green Waste / Leaves / Foliage		

Recommended Maintenance	
No Cleaning Needed	
Schedule Maintenance as Planned	
Needs Immediate Maintenance	

Plant Information	
Damage to Plants	
Plant Replacement	
Plant Trimming	

Additional Notes: \_\_\_\_\_  
 \_\_\_\_\_  
 \_\_\_\_\_



## Cleaning and Maintenance Report Modular Wetlands Linear

Project Name \_\_\_\_\_

For Office Use Only

---

(Reviewed By) \_\_\_\_\_

---

(Date) \_\_\_\_\_  
Office personnel to complete section to the left.

Project Address \_\_\_\_\_  
(city) (Zip Code)

Owner / Management Company \_\_\_\_\_

Contact \_\_\_\_\_ Phone (     )     -     \_\_\_\_\_

Inspector Name \_\_\_\_\_ Date \_\_\_\_ / \_\_\_\_ / \_\_\_\_ Time \_\_\_\_\_ AM / PM

Type of Inspection     Routine     Follow Up     Complaint     Storm    Storm Event in Last 72-hours?     No     Yes

Weather Condition \_\_\_\_\_ Additional Notes \_\_\_\_\_

Site Map #	GPS Coordinates of Insert	Manufacturer / Description / Sizing	Trash Accumulation	Foliage Accumulation	Sediment Accumulation	Total Debris Accumulation	Condition of Media 25/50/75/100 (will be changed @ 75%)	Operational Per Manufactures' Specifications (If not, why?)
	Lat: _____ Long: _____	MWS Catch Basins						
		MWS Sedimentation Basin						
		Media Filter Condition						
		Plant Condition						
		Drain Down Media Condition						
		Discharge Chamber Condition						
		Drain Down Pipe Condition						
		Inlet and Outlet Pipe Condition						

Comments: \_\_\_\_\_  
 \_\_\_\_\_  
 \_\_\_\_\_



## **CONTECH**<sup>®</sup> ENGINEERED SOLUTIONS

© 2022 CONTECH ENGINEERED SOLUTIONS LLC, A QUIKRETE COMPANY

800-338-1122

[WWW.CONTECHES.COM](http://WWW.CONTECHES.COM)

ALL RIGHTS RESERVED. PRINTED IN THE USA.

CONTECH ENGINEERED SOLUTIONS LLC PROVIDES SITE SOLUTIONS FOR THE CIVIL ENGINEERING INDUSTRY. CONTECH'S PORTFOLIO INCLUDES BRIDGES, DRAINAGE, SANITARY SEWER, STORMWATER AND EARTH STABILIZATION PRODUCTS. FOR INFORMATION ON OTHER CONTECH DIVISION OFFERINGS, VISIT [CONTECHES.COM](http://CONTECHES.COM) OR CALL 800-338-1122.

### **SUPPORT**

DRAWINGS AND SPECIFICATIONS ARE AVAILABLE AT [WWW.CONTECHES.COM](http://WWW.CONTECHES.COM)

Modular Wetlands Maintenance Guide 08/22

NOTHING IN THIS CATALOG SHOULD BE CONSTRUED AS A WARRANTY. APPLICATIONS SUGGESTED HEREIN ARE DESCRIBED ONLY TO HELP READERS MAKE THEIR OWN EVALUATIONS AND DECISIONS, AND ARE NEITHER GUARANTEES NOR WARRANTIES OF SUITABILITY FOR ANY APPLICATION. CONTECH MAKES NO WARRANTY WHATSOEVER, EXPRESS OR IMPLIED, RELATED TO THE APPLICATIONS, MATERIALS, COATINGS, OR PRODUCTS DISCUSSED HEREIN. ALL IMPLIED WARRANTIES OF MERCHANTABILITY AND ALL IMPLIED WARRANTIES OF FITNESS FOR ANY PARTICULAR PURPOSE ARE DISCLAIMED BY CONTECH. SEE CONTECH'S CONDITIONS OF SALE (AVAILABLE AT [WWW.CONTECHES.COM/COS](http://WWW.CONTECHES.COM/COS)) FOR MORE INFORMATION.

## Modular Wetlands<sup>®</sup> Linear Concrete Installation Manual



## Overview

The Modular Wetland® Linear Biofilter is designed to remove high levels of trash, debris, sediments, nutrients, metals, and hydrocarbons. Its simple design allows for quick and easy installation. The system is housed in a standard pre-cast structure and can be installed at various depths to meet site-specific conditions.

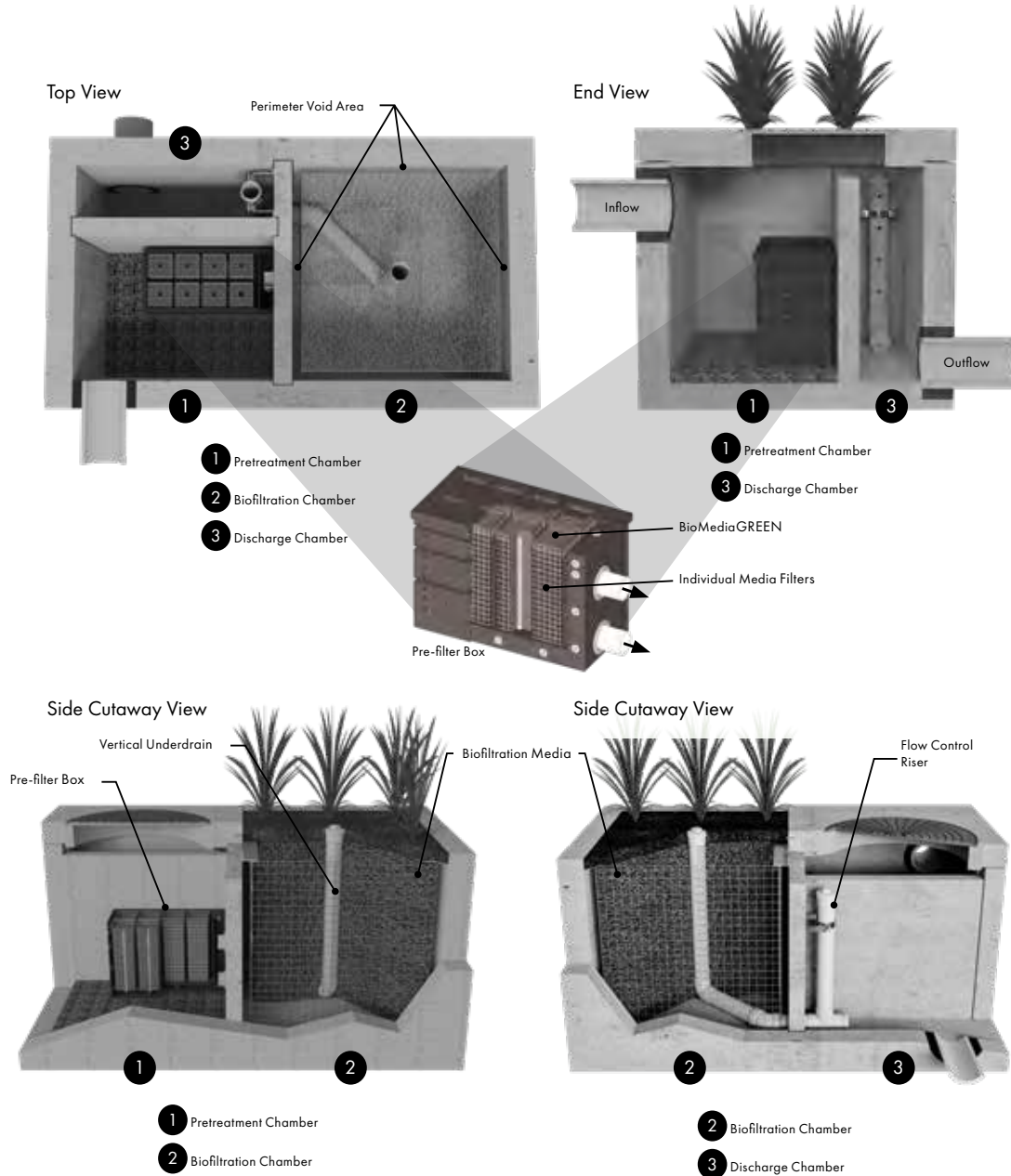

## Introduction

This is the Modular Wetlands® Linear installation manual. Before starting, make sure there is enough room for installing and assembling the product. Inspect all materials for defects and gather the recommended tools listed on the following page. The contractor shall furnish all labor, equipment, materials, and incidentals required to conduct the installation in accordance with the contract documents.

## Instructions

### *Delivery & Unloading / Lifting*

- Contech shall deliver the unit(s) to the site in coordination with the Contractor.
- The Contractor may be required to provide spreader bars and chains/cables to safely and securely lift the base section, risers, and top section along with suitable lifting hooks, knuckles, shackles and eyebolts.
- Please see project specific drawings for weights and lifting details. Contact Contech for additional lifting details.

### *Inspection*

Inspection of the Modular Wetlands® Linear and all parts contained in or shipped outside of the unit shall be inspected at time of delivery by the site Engineer/Inspector and the Contractor. Any nonconformance to approved drawings or damage to any part of the system shall be documented on the Contech shipping ticket.

- Damage to the unit during and after unloading shall be corrected at the expense of the Contractor. Any necessary repairs to the Modular Wetlands® Linear unit shall be made to the acceptance of the Engineer/Inspector.

### *Site Preparation*

- The Contractor is responsible for providing adequate and complete vault protection when the Modular Wetlands® Linear unit is installed prior to final site stabilization (full landscaping, grass cover, final paving, and street sweeping completed) to prevent construction debris or construction phase runoff from entering the unit.
- The Contractor shall adhere to all jurisdictional and/or OSHA safety rules in providing temporary shoring of the excavation.
- The Contractor or Owner is responsible for appropriately barricading the Modular Wetlands® Linear unit from traffic (in accordance with local codes).



- Each Modular Wetlands® Linear unit shall be constructed based on the locations and elevations according to the sizes shown on the approved drawings. Any modifications to the elevation or location shall be at the direction of and approved by the Engineer.
- The Modular Wetlands® Linear unit shall be placed on level compacted sub-grade with a minimum 6-inch gravel base. Compact undisturbed sub-grade materials to be per Geotechnical/Soils report. Unsuitable material below sub-grade shall be replaced to site engineer's approval. Place granular sub-base and compact to State and local standards as per the Engineers requirements.
- Once the base piece is set, the riser(s) and top section should be sealed onto the base section before backfilling, using a non-shrink grout, butyl rubber or similar waterproof seal.
- Pipe connections shall be aligned and sealed to meet the approved drawings with modifications necessary to meet site conditions and local regulations. The correct connection (inlet/outlet) will be marked on the Modular Wetlands® Linear unit.

- NOTE: The inlet and outlet pipe cannot protrude past the structures I.D. wall as it will interfere with the internal components.
- Once the Modular Wetlands® Linear unit is set, it should be protected from construction runoff entering it. Contractor will be responsible for cleaning if unit is contaminated by such construction runoff and associated pollutants and damaged (i.e. concrete wash water).
- Backfilling should be performed in a careful manner, bringing the appropriate fill material up in 6-inch lifts on all sides. Pre-cast sections shall be set in a manner that will result in a watertight joint. In all instances, installation of the Modular Wetlands® Linear unit shall conform to ASTM specification C891 "Standard Practice for Installation of Underground Precast Utility Structures" unless specified otherwise in contract documents.
- If applicable, it is the responsibility of the Contractor to provide curb and gutter and transition to the Modular Wetlands® Linear unit for proper stormwater flow into the system through the throat, pipe or grate opening. A standard drawing of the throat and gutter detail is available in the following section; however the plans and contract documents supersede all standard drawings. Several variations of the standard design are available. Effective bypass for an offline Modular Wetlands® Linear unit is essential for correct operation (i.e. bypass to an overflow at lower elevation).

## Installation

1. Each Modular Wetlands® Linear unit shall be constructed based on the locations and elevations according to the sizes shown on the approved drawings. Any modifications to the elevation or location shall be at the direction of and approved by the Engineer.



*Position crane in a safe and optimal position for unloading. Ensure that the crane operator has the proper weights and distance to install location to allow for proper setup. The crane operator will provide instructions to the delivery driver on where to position the truck for offload.*

2. The Modular Wetlands® Linear unit shall be placed on level compacted sub-grade with a minimum 6-inch gravel base and mark the base. Compact undisturbed subgrade materials to be per Geotechnical/Soils report. Unsuitable material below sub-grade shall be replaced to site engineer's approval. Place granular sub-base and compact to State and local standards as per the Engineer's requirements.

3. Pipe material selection should be indicated on the Site Plan. Connect the pipe using a Kor-N-Seal, Press Seal, Fernco, or other approved watertight boot connection. In the case of concrete pipes, grout the connection watertight with non-shrink grout.



*The contractor is responsible to provide the appropriate rigging and lifting connectors. Spreader bars are recommended to prevent damage to the concrete vault. All lifting points on the concrete vault must be used for safe offloading. Guide ropes can be used to stabilize the vault during offloading.*

4. Lift the vault off of the delivery truck and safely move vault over the excavated area for installation. Before setting the vault ensure the hole is the right size, level, and properly sized.



5. Position the concrete vault over the excavated area and slowly lower into position. Ensure the inlet and outlet sides of the vault are in the correct position and the correct elevations are verified.



6. Once the vault is set in place, check all four corners are in the correct position. Take tension off of the rigging to ensure the vault is set properly and the compacted rock backfill below is holding the weight of the vault.



7. Use a string and or level to make sure the vault is level in both directions. The vault cannot be more than 0.5% slope off from level in any direction. If the vault slopes more than 0.5%, pick back up, move to a safe area, re-level the rock below and reset until properly level.

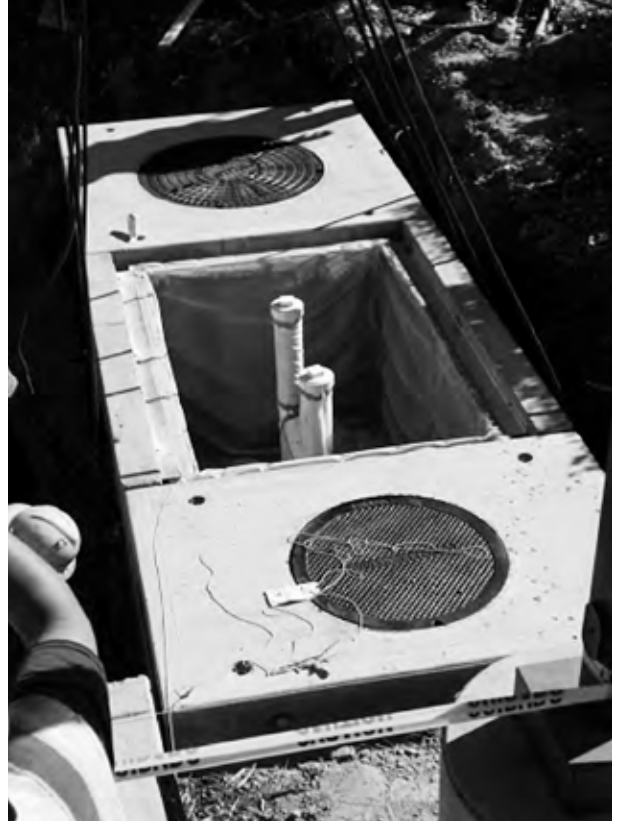

8. After pipe connections are completed, backfill in 12 inch increments and compact per local and state requirements. If curb type configurations, pour and connect curb and gutter system as shown in the picture to the right.

The last step is to install the wetland media that can be delivered in super sacks or in bulk based on preference. Install the plant propagation blocks as shown in the drawings below. Install the vegetation and cover with decorative rock and mulch.



## **Pipe Connections**

- Pipe material selection should be indicated on the Site Plan. Connect the pipe using a Kor-N-Seal, Press Seal, Fernco, or other approved watertight boot connection. In the case of concrete pipes, grout the connection watertight with non-shrink grout
- Inlet pipe(s) shall be stubbed in and connected to the precast manhole according to the Engineer's requirement or specifications. The Contractor is to grout all inlet pipes flush with the interior wall of the structure per plans and specifications.
- Outlet pipe shall be stubbed in and connected to the precast manhole according to the Engineer's requirement or specifications. The Contractor is to grout all inlet pipes flush with the interior wall of the structure per plans and specifications.
- For illustration a BAD example of a pipe installation is included below. The pipe is off-center, the pipe invert is not in the appropriate position, it is protruding beyond the inside wall, the grout is not clean and properly finished. This site was corrected by re-excavating and reconnecting the pipe properly.



*Example of a BAD pipe installation. Protruding past the internal wall of the structure, poor grouting, and wrong position.*



*Example of a GOOD pipe installation. Pipe flush with the internal wall of the structure, clean grouting, and proper position.*

- Once the pipes are connected, carefully backfill around them, compacting in "lifts" that will not deflect, disturb or damage them.

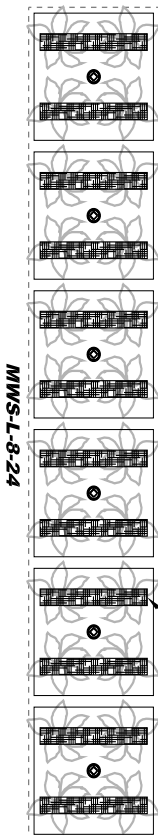
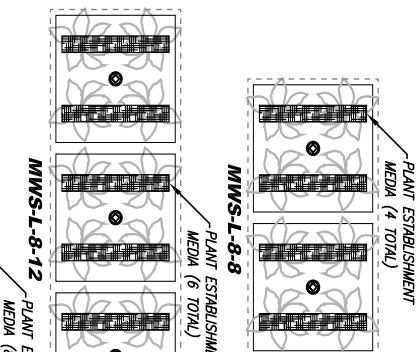
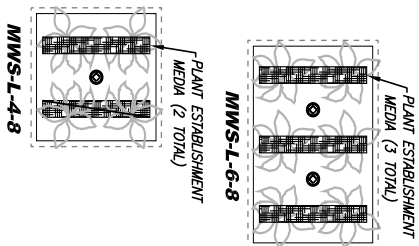
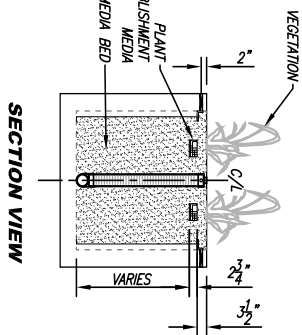
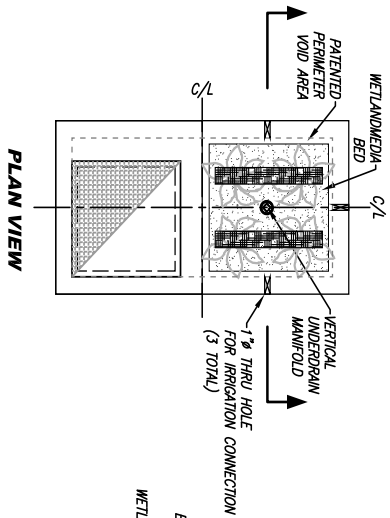

**VEGETATION AND IRRIGATION NOTES:**

1. VEGETATION SUPPLIED AND INSTALLED BY OTHERS. ALL UNITS WITH VEGETATION MUST HAVE DRIP OR SPRAY IRRIGATION SUPPLIED AND INSTALLED BY OTHERS.
2. BEFORE SELECTING VEGETATION SEE BIO CLEAN PLANT HARDY ZONE RECOMMENDATIONS.
3. IRRIGATION THRU HOLE IS 1/2" AND IS DESIGNED TO BE CONNECTED TO A 1/2" IRRIGATION LINE. IRRIGATION THRU HOLE IS LOCATED ON CENTER OF WETLAND CHAMBER 2" DOWN FROM THE TOP OF THE SYSTEM.
4. IRRIGATION SYSTEM FOR MODULAR WETLAND SYSTEM CAN BE PLACED ON SAME VALVE AS SURROUNDING PLANTING AREAS AND REQUIRES NO SPECIAL WATERING NEEDS.

**INSTALLATION NOTES**

1. CONTRACTOR TO PROVIDE ALL LABOR, EQUIPMENT, MATERIALS AND INCIDENTALS REQUIRED TO OFFLOAD AND INSTALL THE SYSTEM AND APPURTENANCES, IN ACCORDANCE WITH THIS DRAWING AND THE MANUFACTURER'S SPECIFICATIONS, UNLESS OTHERWISE STATED IN MANUFACTURER'S CONTRACT.
2. UNIT MUST BE INSTALLED ON LEVEL BASE. MANUFACTURER RECOMMENDS A MINIMUM 6" LEVEL ROCK BASE UNLESS SPECIFIED BY THE PROJECT ENGINEER. CONTRACTOR IS RESPONSIBLE FOR VERIFYING PROJECT ENGINEER'S RECOMMENDED BASE SPECIFICATIONS.
3. CONTRACTOR TO SUPPLY AND INSTALL ALL EXTERNAL CONNECTING PIPES. ALL PIPES MUST BE FLUSH WITH INSIDE SURFACE OF CONCRETE (PIPES CANNOT INTRUDE BEYOND FLUSH). INVERT OF OUTFLOW PIPE MUST BE FLUSH WITH DISCHARGE CHAMBER FLOOR. ALL PIPES SHALL BE SEALED WATER-TIGHT PER MANUFACTURER'S STANDARD CONNECTION DETAIL.
4. CONTRACTOR RESPONSIBLE FOR INSTALLATION OF ALL PIPES, RESERVOIR, MANHOLES, AND TAPES. CONTRACTOR TO USE GROUT AND/OR BRICKS TO MATCH COVERS WITH FINISHED SURFACE UNLESS SPECIFIED OTHERWISE.
5. CONTRACTOR RESPONSIBLE FOR CONTRACTING BIO CLEAN FOR ACTIVATION OF UNIT. MANUFACTURER'S WARRANTY IS VOID WITHOUT PROPER ACTIVATION BY A BIO CLEAN REPRESENTATIVE.



PROPRIETARY AND CONFIDENTIAL: THE INFORMATION CONTAINED IN THIS DOCUMENT IS THE SOLE PROPERTY OF WETLANDS. IT IS TO BE USED ONLY FOR THE PROJECT AND NOT BE REPRODUCED OR COPIED IN ANY MANNER WITHOUT THE WRITTEN CONSENT OF WETLANDS.



STORMWATER BIOFILTRATION SYSTEM  
PLANTER INSTALLATION

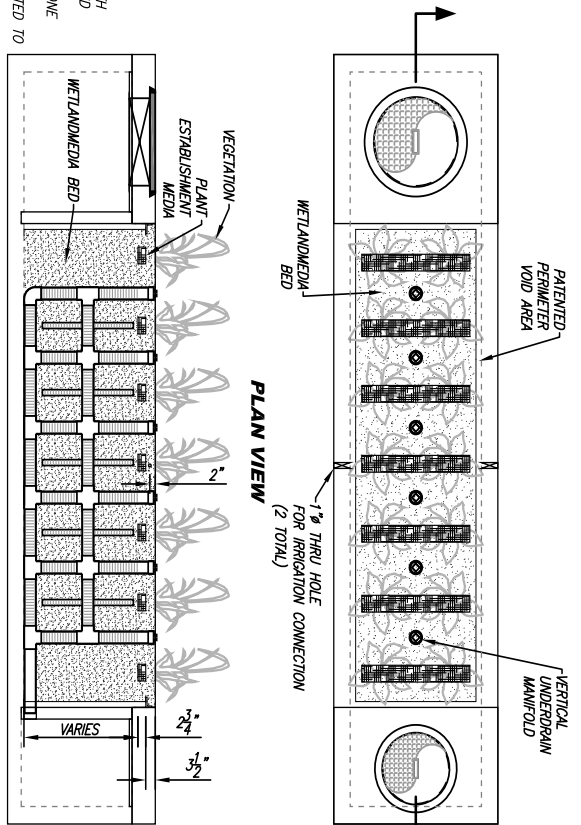

- VEGETATION AND IRRIGATION NOTES:**
1. VEGETATION SUPPLIED AND INSTALLED BY OTHERS. ALL UNITS WITH VEGETATION MUST HAVE DRIP OR SPRAY IRRIGATION SUPPLIED AND INSTALLED BY OTHERS.
  2. BEFORE SELECTING VEGETATION SEE BIO CLEAN PLANT HARDY ZONE RECOMMENDATIONS.
  3. IRRIGATION THRU HOLE IS 1"Ø AND IS DESIGNED TO BE CONNECTED TO A 1/2"Ø IRRIGATION LINE. IRRIGATION THRU HOLE IS LOCATED ON CENTER OF WETLAND CHAMBER 2" DOWN FROM THE TOP OF THE SYSTEM.
  4. IRRIGATION SYSTEM FOR MODULAR WETLAND SYSTEM CAN BE PLACED ON SAME VALVE AS SURROUNDING PLANTING AREAS AND REQUIRES NO SPECIAL WATERING NEEDS.

**INSTALLATION NOTES**

1. CONTRACTOR TO PROVIDE ALL LABOR, EQUIPMENT, MATERIALS AND INCIDENTALS REQUIRED TO OFFLOAD AND INSTALL THE SYSTEM AND ADJUSTMENTS IN ACCORDANCE WITH THIS DRAWING AND THE MANUFACTURER'S SPECIFICATIONS, UNLESS OTHERWISE STATED IN MANUFACTURER'S CONTRACT.
2. UNIT MUST BE INSTALLED ON LEVEL BASE. MANUFACTURER RECOMMENDS A MINIMUM 6" LEVEL ROCK BASE UNLESS SPECIFIED BY THE PROJECT ENGINEER. CONTRACTOR IS RESPONSIBLE FOR VERIFYING CONTRACTOR TO SUPPLY AND INSTALL ALL EXTERNAL CONNECTING PIPES. ALL PIPES MUST BE FLUSH WITH INSIDE SURFACE OF CONCRETE (PIPES CANNOT INTRUDE BEYOND FLUSH). INNER OR OUTFLOW PIPE MUST BE FLUSH WITH DISCHARGE CHAMBER FLOOR. ALL PIPES SHALL BE SEALED WATERTIGHT PER MANUFACTURER'S STANDARD CONNECTION DETAIL.
5. CONTRACTOR RESPONSIBLE FOR INSTALLATION OF ALL PIPES, RISERS, MANHOLES, AND HATCHES. CONTRACTOR TO USE GROUT AND/OR BRICKS TO MATCH COVERS WITH FINISHED SURFACE UNLESS SPECIFIED OTHERWISE.
6. CONTRACTOR RESPONSIBLE FOR CONTRACTING BIO CLEAN FOR ACTIVATION OF UNIT. MANUFACTURER'S WARRANTY IS VOID WITHOUT PROPER ACTIVATION BY A BIO CLEAN REPRESENTATIVE.

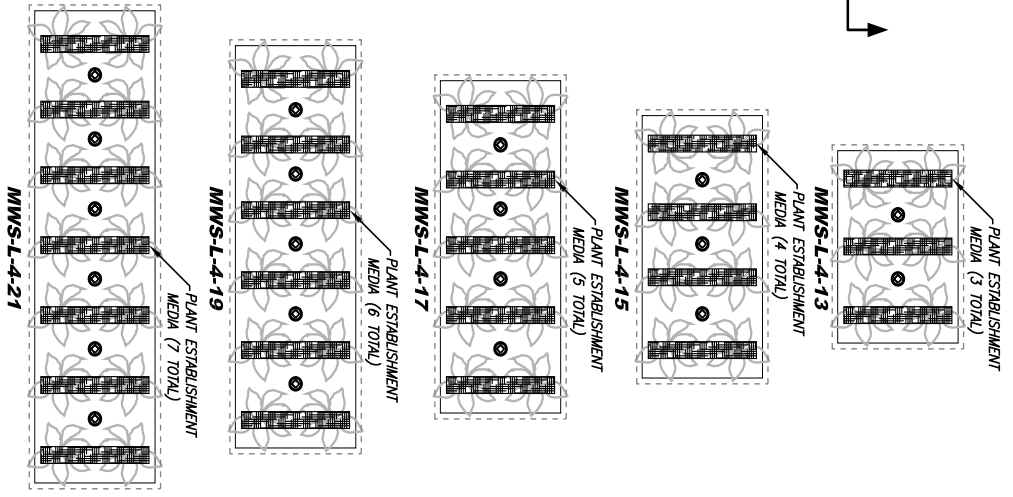

**WETLANDS**  
 THE PRODUCT AND SERVICE ARE PROVIDED BY OR ON BEHALF OF THE MANUFACTURER. THE MANUFACTURER'S WARRANTY IS VOID WITHOUT PROPER ACTIVATION BY A BIO CLEAN REPRESENTATIVE.

PROPRIETARY AND CONFIDENTIAL.  
 THE INFORMATION CONTAINED IN THIS DOCUMENT IS THE SOLE PROPERTY OF CONTECH. IT IS TO BE USED, REPRODUCED OR MOVED IN ANY MANNER WITHOUT THE WRITTEN CONSENT OF FORTIBRA.

**CONTECH**  
 ENGINEERED SOLUTIONS

STORMWATER BIOFILTRATION SYSTEM  
 PLANTER INSTALLATION

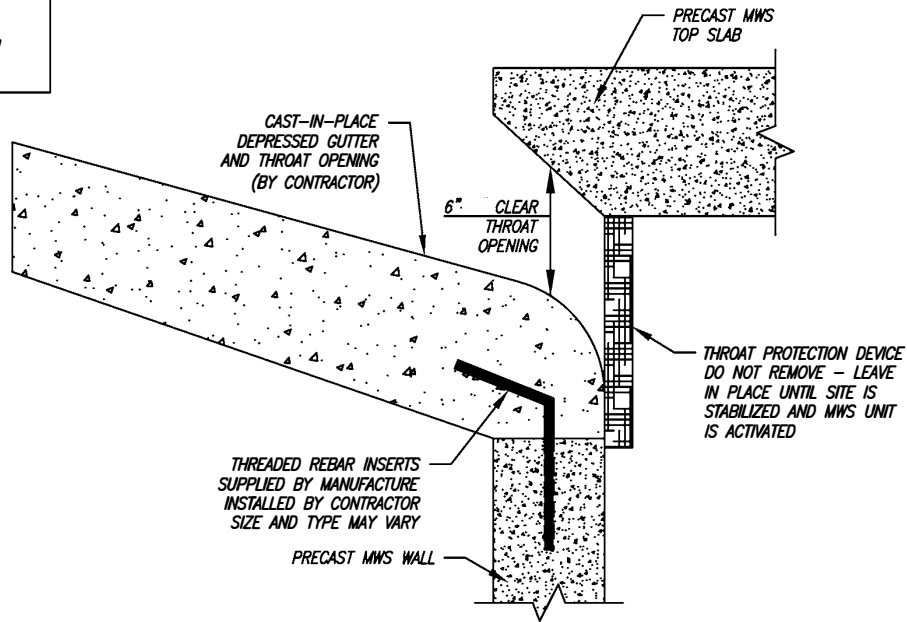

SECTION VIEW  
STANDARD MODULAR WETLAND CURB OPENING

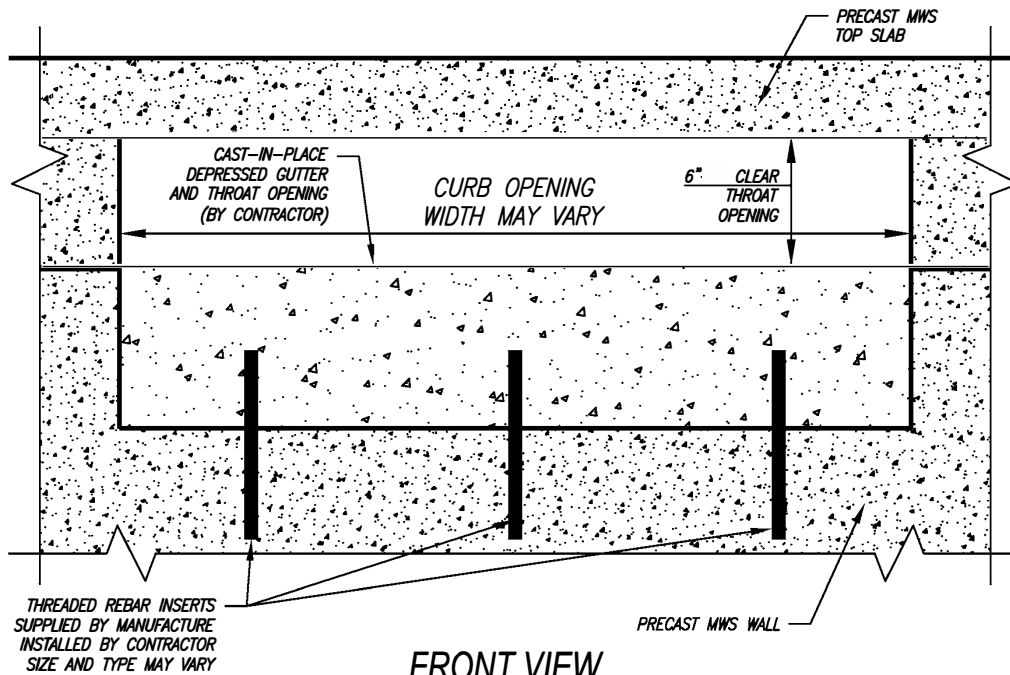

FRONT VIEW  
STANDARD MODULAR WETLAND CURB OPENING

MODULAR WETLAND SYSTEMS INC.  
P.O. BOX 869  
OCEANSIDE, CA 92019  
www.ModularWetlands.com

BY: W/N  
EDITED

NAME: John  
DATE: 5/3/13

TITLE: MWS LINEAR 2.0  
CURB INLET DETAILS

PROPRIETARY AND CONFIDENTIAL

THE INFORMATION CONTAINED IN THIS DRAWING IS THE SOLE PROPERTY OF MODULAR WETLAND SYSTEMS INC. ANY REPRODUCTION IN PART OR AS A WHOLE WITHOUT THE WRITTEN PERMISSION OF MODULAR WETLAND SYSTEMS INC. IS PROHIBITED.

COMMENTS:

SIZE: DWG. NO.

REV

SCALE: NTS UNITS: INCHES SHEET 1 OF 1



## **CONTECH**<sup>®</sup> ENGINEERED SOLUTIONS

© 2022 CONTECH ENGINEERED SOLUTIONS LLC, A QUIKRETE COMPANY

800-338-1122

[WWW.CONTECHES.COM](http://WWW.CONTECHES.COM)

ALL RIGHTS RESERVED. PRINTED IN THE USA.

CONTECH ENGINEERED SOLUTIONS LLC PROVIDES SITE SOLUTIONS FOR THE CIVIL ENGINEERING INDUSTRY. CONTECH'S PORTFOLIO INCLUDES BRIDGES, DRAINAGE, SANITARY SEWER, STORMWATER AND EARTH STABILIZATION PRODUCTS. FOR INFORMATION ON OTHER CONTECH DIVISION OFFERINGS, VISIT [CONTECHES.COM](http://CONTECHES.COM) OR CALL 800-338-1122.

NOTHING IN THIS CATALOG SHOULD BE CONSTRUED AS A WARRANTY. APPLICATIONS SUGGESTED HEREIN ARE DESCRIBED ONLY TO HELP READERS MAKE THEIR OWN EVALUATIONS AND DECISIONS, AND ARE NEITHER GUARANTEES NOR WARRANTIES OF SUITABILITY FOR ANY APPLICATION. CONTECH MAKES NO WARRANTY WHATSOEVER, EXPRESS OR IMPLIED, RELATED TO THE APPLICATIONS, MATERIALS, COATINGS, OR PRODUCTS DISCUSSED HEREIN. ALL IMPLIED WARRANTIES OF MERCHANTABILITY AND ALL IMPLIED WARRANTIES OF FITNESS FOR ANY PARTICULAR PURPOSE ARE DISCLAIMED BY CONTECH. SEE CONTECH'S CONDITIONS OF SALE (AVAILABLE AT [WWW.CONTECHES.COM/COS](http://WWW.CONTECHES.COM/COS)) FOR MORE INFORMATION.

### **SUPPORT**

DRAWINGS AND SPECIFICATIONS ARE AVAILABLE AT [WWW.CONTECHES.COM](http://WWW.CONTECHES.COM)

Modular Wetland Linear Install Guide 08/22



# Modular Wetlands<sup>®</sup> Linear Stormwater Biofiltration



# The experts you need to solve your stormwater challenges



**Contech is the leader in stormwater solutions, helping engineers, contractors and owners with infrastructure and land development projects throughout North America.**

With our responsive team of stormwater experts, local regulatory expertise and flexible solutions, Contech is the trusted partner you can count on for stormwater management solutions.

## Your Contech Team



### **STORMWATER CONSULTANT**

*It's my job to recommend the best solution to meet permitting requirements.*



### **STORMWATER DESIGN ENGINEER**

*I work with consultants to design the best approved solution to meet your project's needs.*



### **REGULATORY MANAGER**

*I understand the local stormwater regulations and what solutions will be approved.*



### **SALES ENGINEER**

*I make sure our solutions meet the needs of the contractor during construction.*

**Contech is your partner in stormwater management solutions**



## Restoring Nature's Presence in Urban Areas – Modular Wetlands® Linear

The Modular Wetlands® Linear is the only biofiltration system to utilize patented horizontal flow, allowing for a small footprint, high treatment capacity, and design versatility. It is also the only biofiltration system that can be routinely installed downstream of storage for additional volume control and treatment.

With numerous regulatory approvals, the system's aesthetic appeal and superior pollutant removal make it the ideal solution for a wide range of stormwater applications, including urban development projects, commercial parking lots, residential streets, mixed-use developments, streetscapes, and more.

*As cities grow, there is less space for natural solutions to treat stormwater. Contech understands this and is committed to providing compact, Low Impact Development (LID) solutions like the Modular Wetlands Linear to protect our nation's waterways.*



# How the Modular Wetlands® Linear Works

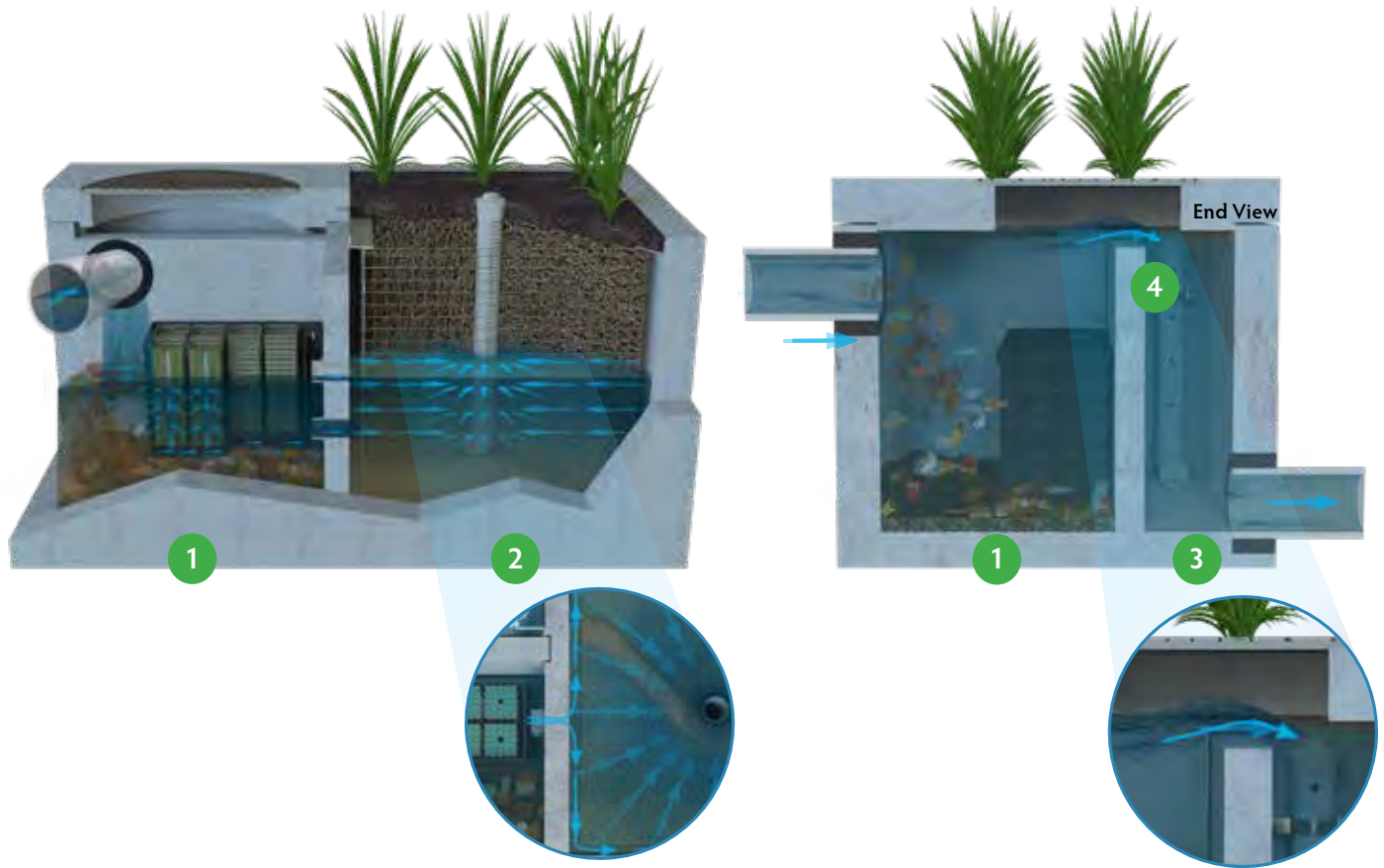

- 1 PRETREATMENT** | Stormwater enters the pretreatment chamber where total suspended solids settle, and trash and debris are contained within the chamber. Stormwater then travels through the pretreatment filter boxes that provide additional treatment.
- 2 BIOFILTRATION** | As water enters the biofiltration chamber, it fills the void space in the chamber's perimeter. Horizontal forces push the water inward through the biofiltration media, where nutrients and metals are captured. The water then enters the drain pipe to be discharged.
- 3 DISCHARGE** | The specially designed vertical drain pipe and orifice control plate control the flow of water through the media to a level lower than the media's capacity, ensuring media effectiveness. The water then enters the horizontal drain pipe to be discharged.
- 4 BYPASS** | During peak flows, an internal weir in the side-by-side configuration allows high flows to bypass treatment, eliminating flooding and the need for a separate bypass structure. Bypass is not provided in the end-to-end configuration.

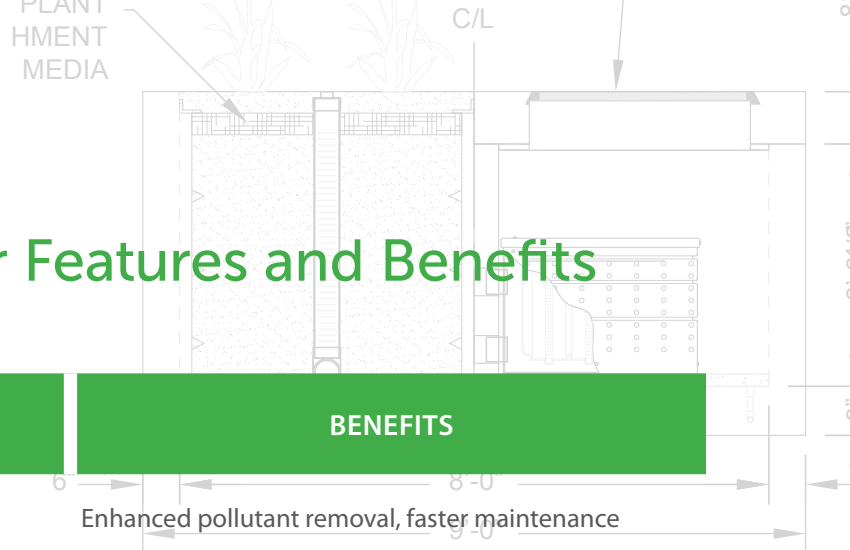

# Modular Wetlands<sup>®</sup> Linear Features and Benefits

FEATURE	BENEFITS
Pretreatment chamber	Enhanced pollutant removal, faster maintenance
Horizontal flow biofiltration	Greater filter surface area
Performance verified by both the WA DOE and NJ DEP	Superior pollutant capture with confidence
Built-in high flow bypass	Eliminates flooding and the need for a separate bypass structure
Available in multiple configurations and sizes	Flexibility to meet site-specific needs



The Modular Wetlands system offers many different configurations.

## Select Modular Wetlands<sup>®</sup> Linear Approvals

Modular Wetlands Linear is approved through numerous local, state and federal programs, including but not limited to:

- Washington State Department of Ecology TAPE
- California Water Resources Control Board, Full Capture Certification
- Virginia Department of Environmental Quality (VA DEQ)
- New Jersey Department of Environmental Protection (NJDEP)
- Maryland Department of the Environment - Environmental Site Design (ESD)
- Rhode Island Department of Environmental Management BMP
- Texas Commission on Environmental Quality (TCEQ)
- Atlanta Regional Commission Certification



MEDIA

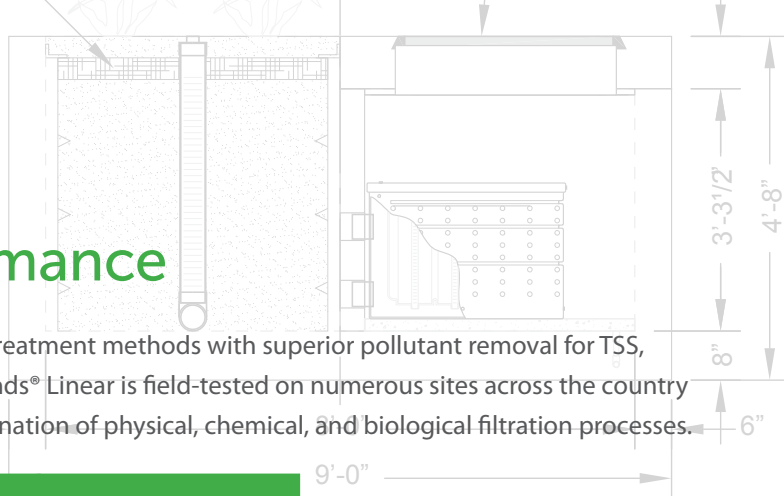

## Modular Wetlands® Performance

The Modular Wetlands® Linear continues to outperform other treatment methods with superior pollutant removal for TSS, heavy metals, nutrients, and hydrocarbons. The Modular Wetlands® Linear is field-tested on numerous sites across the country and is proven to effectively remove pollutants through a combination of physical, chemical, and biological filtration processes.

POLLUTANT OF CONCERN	MEDIAN REMOVAL EFFICIENCY	MEDIAN EFFLUENT CONCENTRATION (MG/L)
Total Suspended Solids (TSS)	89%	12
Total Phosphorus - TAPE (TP)	61%	0.041
Nitrogen (TN)	23%	1
Total Copper (TCu)	50%	0.006
Total Dissolved Copper	37%	0.006
Total Zinc (TZn)	66%	0.019
Dissolved Zinc	60%	0.0148
Motor Oil	79%	0.8

Sources:  
 TAPE Field Study - 2012  
 TAPE Field Study - 2013

*Note: Some jurisdictions recognize higher removal rates. Contact your Contech Stormwater Consultant for performance expectations.*

## Modular Wetlands® Linear Maintenance

The Modular Wetlands® Linear is a self-contained treatment train. Maintenance requirements for the unit consist of five simple steps that can be completed using a vacuum truck. The system can also be cleaned by hand.

- Remove trash from the screening device
- Remove sediment from the separation chamber
- Periodically replace the pretreatment cartridge filter media
- Replace the drain down filter media
- Trim vegetation



*Most Modular Wetland Linear systems can be cleaned in about thirty minutes.*

**Multiple configurations allow for easy site integration**

# Modular Wetlands<sup>®</sup> Linear Configurations

Multiple system configurations integrate with site hydraulic design and layout ...

The Modular Wetlands Linear is offered in multiple configurations to meet site specific needs. This highly versatile system has available "pipe-in" options on most models, along with built-in curb or grated inlets for simple integration into your storm drain design.

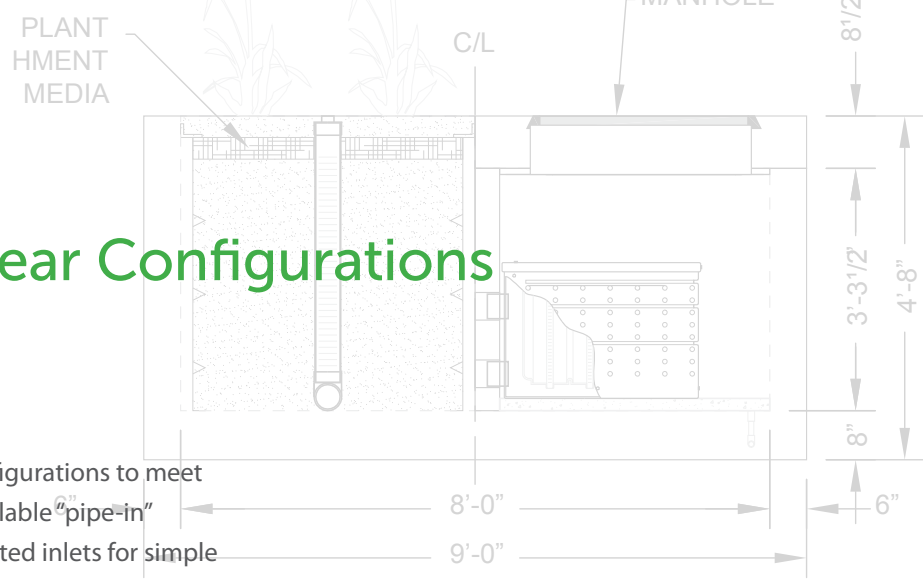

## Curb Inlet

The Curb Inlet configuration accepts sheet flow through a curb opening and is commonly used along roadways and parking lots. It can be used in sump or flow-by conditions.



## Vault

The Vault configuration can be used in end-of-the-line installations. Another benefit of the "pipe-in" design is the ability to install the system downstream of underground detention systems to meet water quality volume requirements, or for traffic-rated designs (no plants).

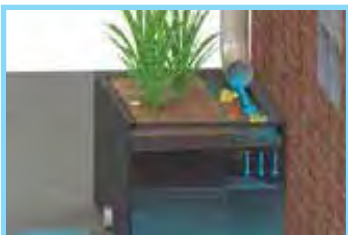

## Downspout

The Downspout configuration is designed to accept a vertical downspout pipe from rooftop and podium areas. Some models have the option of utilizing an internal bypass, simplifying the overall design. The system can be installed as a raised planter, and the exterior can be stuccoed or covered with other finishes to match the look of adjacent buildings.

# A partner you can rely on



STORMWATER  
SOLUTIONS



PIPE  
SOLUTIONS



STRUCTURES  
SOLUTIONS

Few companies offer the wide range of high-quality stormwater resources you can find with us — state-of-the-art products, decades of expertise, and all the maintenance support you need to operate your system cost-effectively.

#### THE CONTECH WAY

Contech® Engineered Solutions provides innovative, cost-effective site solutions to engineers, contractors, and developers on projects across North America. Our portfolio includes bridges, drainage, erosion control, retaining wall, sanitary sewer and stormwater management products.

#### TAKE THE NEXT STEP

For more information: [www.ContechES.com](http://www.ContechES.com)

NOTHING IN THIS CATALOG SHOULD BE CONSTRUED AS A WARRANTY. APPLICATIONS SUGGESTED HEREIN ARE DESCRIBED ONLY TO HELP READERS MAKE THEIR OWN EVALUATIONS AND DECISIONS, AND ARE NEITHER GUARANTEES NOR WARRANTIES OF SUITABILITY FOR ANY APPLICATION. CONTECH MAKES NO WARRANTY WHATSOEVER, EXPRESS OR IMPLIED, RELATED TO THE APPLICATIONS, MATERIALS, COATINGS, OR PRODUCTS DISCUSSED HEREIN. ALL IMPLIED WARRANTIES OF MERCHANTABILITY AND ALL IMPLIED WARRANTIES OF FITNESS FOR ANY PARTICULAR PURPOSE ARE DISCLAIMED BY CONTECH. SEE CONTECH'S CONDITIONS OF SALE (AVAILABLE AT [WWW.CONTECHES.COM/COS](http://WWW.CONTECHES.COM/COS)) FOR MORE INFORMATION.

**CONTECH**<sup>®</sup>  
ENGINEERED SOLUTIONS

Get social with us:



800-338-1122 | [www.ContechES.com](http://www.ContechES.com)

## User Inputs

<b>Chamber Model:</b>	MC-7200
<b>Outlet Control Structure:</b>	No
<b>Project Name:</b>	139-1 - DMA-A
<b>Engineer:</b>	Steve Levissee
<b>Project Location:</b>	California
<b>Measurement Type:</b>	Imperial
<b>Required Storage Volume:</b>	2043 cubic ft.
<b>Stone Porosity:</b>	40%
<b>Stone Foundation Depth:</b>	9 in.
<b>Stone Above Chambers:</b>	12 in.
<b>Average Cover Over Chambers:</b>	24 in.
<b>Design Constraint Dimensions:</b>	(20 ft. x 40 ft.)

## Results

### System Volume and Bed Size

<b>Installed Storage Volume:</b>	2353.76 cubic ft.
<b>Storage Volume Per Chamber:</b>	175.90 cubic ft.
<b>Number Of Chambers Required:</b>	6
<b>Number Of End Caps Required:</b>	4
<b>Chamber Rows:</b>	2
<b>Maximum Length:</b>	31.01 ft.
<b>Maximum Width:</b>	19.42 ft.
<b>Approx. Bed Size Required:</b>	602.12 square ft.

### System Components

<b>Amount Of Stone Required:</b>	106 cubic yards
<b>Volume Of Excavation (Not Including Fill):</b>	151 cubic yards
<b>Total Non-woven Geotextile Required:</b>	252 square yards
<b>Woven Geotextile Required (excluding Isolator Row):</b>	22 square yards
<b>Woven Geotextile Required (Isolator Row):</b>	59 square yards
<b>Total Woven Geotextile Required:</b>	81 square yards

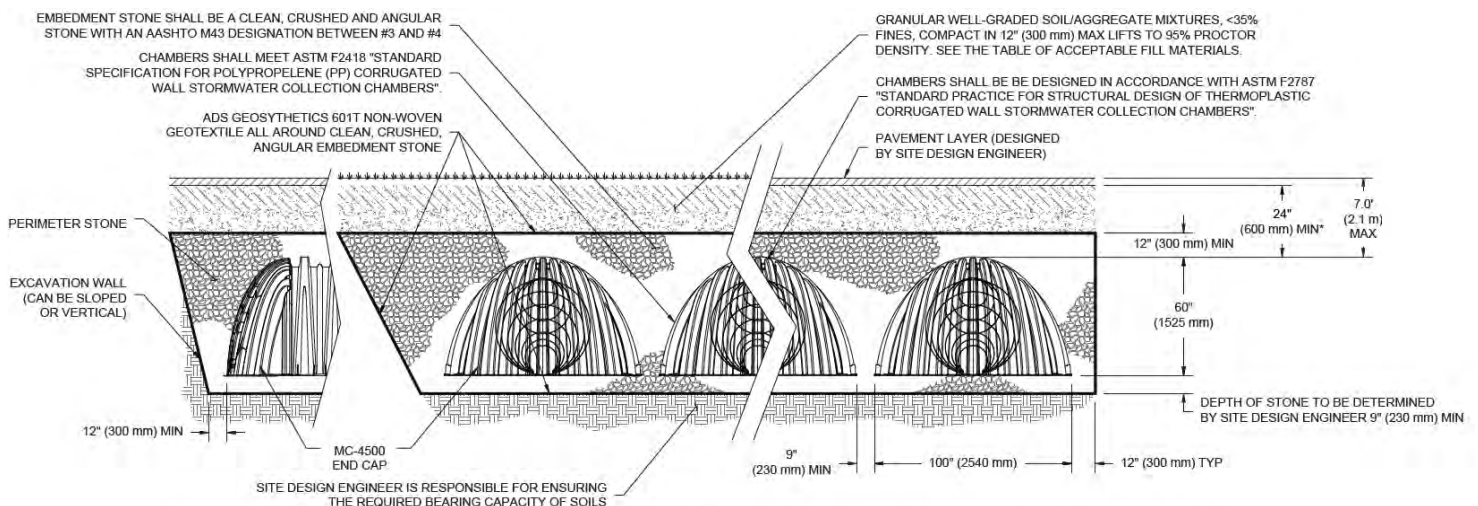

## User Inputs

<b>Chamber Model:</b>	MC-7200
<b>Outlet Control Structure:</b>	No
<b>Project Name:</b>	139-1 - DMA - I
<b>Engineer:</b>	Steve Levissee
<b>Project Location:</b>	California
<b>Measurement Type:</b>	Imperial
<b>Required Storage Volume:</b>	3867 cubic ft.
<b>Stone Porosity:</b>	40%
<b>Stone Foundation Depth:</b>	9 in.
<b>Stone Above Chambers:</b>	12 in.
<b>Average Cover Over Chambers:</b>	24 in.
<b>Design Constraint Dimensions:</b>	(20 ft. x 60 ft.)

## Results

### System Volume and Bed Size

<b>Installed Storage Volume:</b>	4313.15 cubic ft.
<b>Storage Volume Per Chamber:</b>	175.90 cubic ft.
<b>Number Of Chambers Required:</b>	13
<b>Number Of End Caps Required:</b>	4
<b>Chamber Rows:</b>	2
<b>Maximum Length:</b>	57.38 ft.
<b>Maximum Width:</b>	19.42 ft.
<b>Approx. Bed Size Required:</b>	1054.20 square ft.

### System Components

<b>Amount Of Stone Required:</b>	173 cubic yards
<b>Volume Of Excavation (Not Including Fill):</b>	264 cubic yards
<b>Total Non-woven Geotextile Required:</b>	420 square yards
<b>Woven Geotextile Required (excluding Isolator Row):</b>	22 square yards
<b>Woven Geotextile Required (Isolator Row):</b>	121 square yards
<b>Total Woven Geotextile Required:</b>	142 square yards

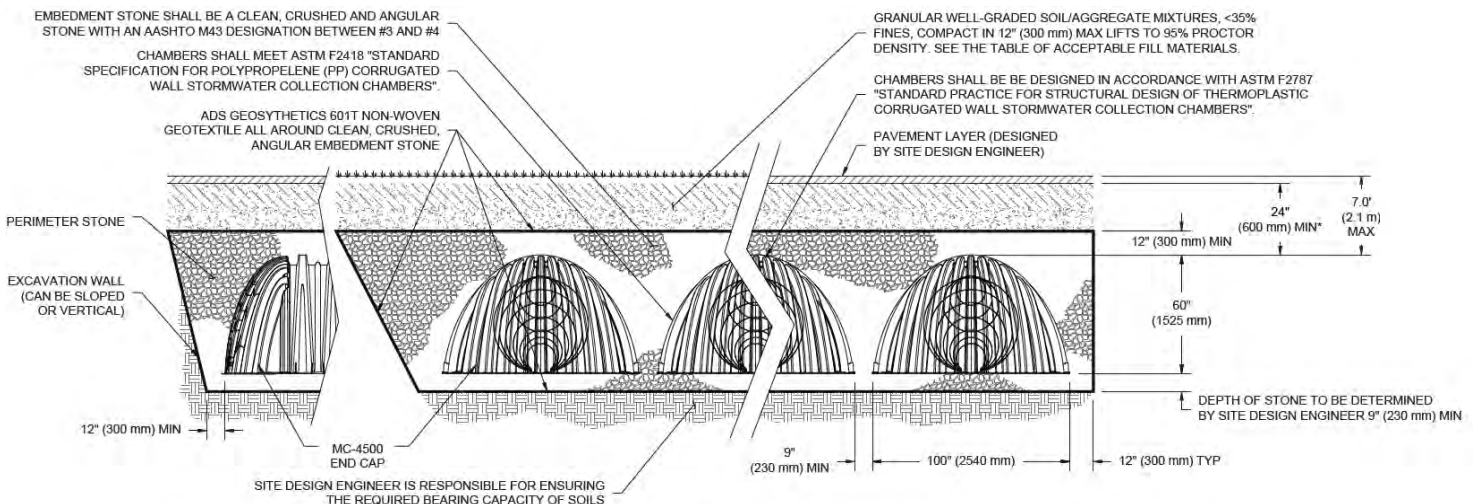

\*MINIMUM COVER TO BOTTOM OF FLEXIBLE PAVEMENT. FOR UNPAVED INSTALLATIONS WHERE RUTTING FROM VEHICLES MAY OCCUR, INCREASE COVER TO 30" (750 mm).



## User Inputs

<b>Chamber Model:</b>	MC-7200
<b>Outlet Control Structure:</b>	Yes
<b>Project Name:</b>	139-1 - DMA J
<b>Engineer:</b>	Steve Levissee
<b>Project Location:</b>	California
<b>Measurement Type:</b>	Imperial
<b>Required Storage Volume:</b>	35220 cubic ft.
<b>Stone Porosity:</b>	40%
<b>Stone Foundation Depth:</b>	9 in.
<b>Stone Above Chambers:</b>	12 in.
<b>Average Cover Over Chambers:</b>	24 in.
<b>Design Constraint Dimensions:</b>	(100 ft. x 160 ft.)

## Results

### System Volume and Bed Size

<b>Installed Storage Volume:</b>	36126.10 cubic ft.
<b>Storage Volume Per Chamber:</b>	175.90 cubic ft.
<b>Number Of Chambers Required:</b>	124
<b>Number Of End Caps Required:</b>	12
<b>Chamber Rows:</b>	6
<b>Maximum Length:</b>	150.38 ft.
<b>Maximum Width:</b>	56.35 ft.
<b>Approx. Bed Size Required:</b>	8427.68 square ft.

### System Components

<b>Amount Of Stone Required:</b>	1282 cubic yards
<b>Volume Of Excavation (Not Including Fill):</b>	2107 cubic yards
<b>Total Non-woven Geotextile Required:</b>	2620 square yards
<b>Woven Geotextile Required (excluding Isolator Row):</b>	107 square yards
<b>Woven Geotextile Required (Isolator Row):</b>	336 square yards
<b>Total Woven Geotextile Required:</b>	442 square yards

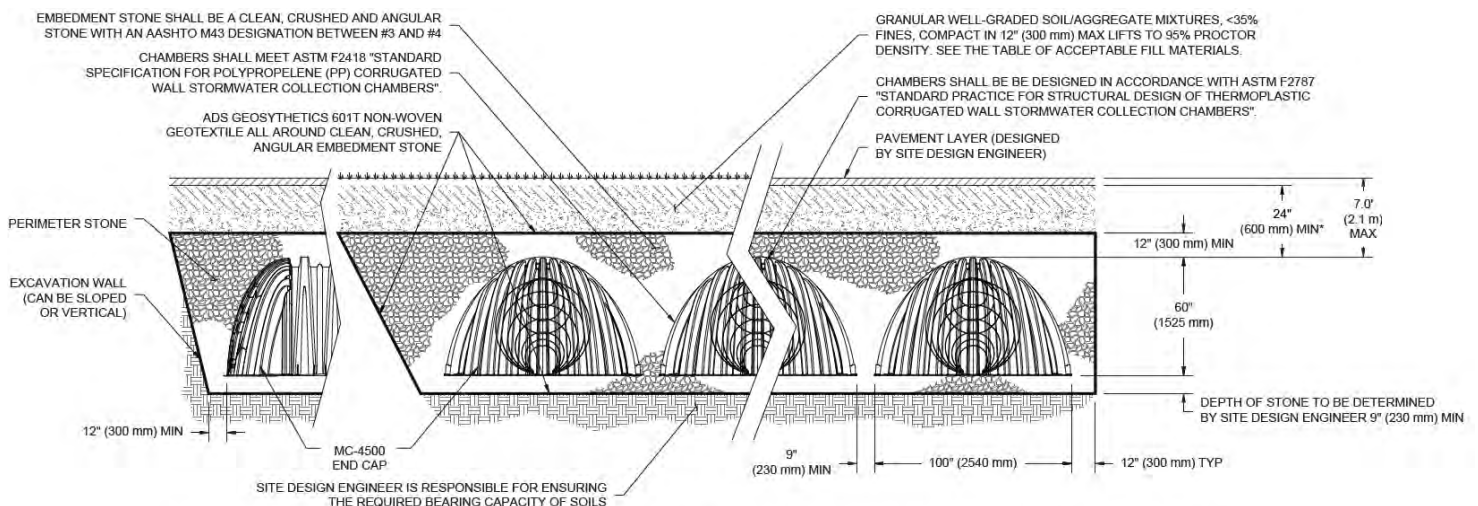

\*MINIMUM COVER TO BOTTOM OF FLEXIBLE PAVEMENT. FOR UNPAVED INSTALLATIONS WHERE RUTTING FROM VEHICLES MAY OCCUR, INCREASE COVER TO 30" (750 mm).



## User Inputs

<b>Chamber Model:</b>	MC-7200
<b>Outlet Control Structure:</b>	Yes
<b>Project Name:</b>	139-1 - DMA - K
<b>Engineer:</b>	Steve Levissee
<b>Project Location:</b>	California
<b>Measurement Type:</b>	Imperial
<b>Required Storage Volume:</b>	31519 cubic ft.
<b>Stone Porosity:</b>	40%
<b>Stone Foundation Depth:</b>	9 in.
<b>Stone Above Chambers:</b>	12 in.
<b>Average Cover Over Chambers:</b>	24 in.
<b>Design Constraint Dimensions:</b>	(100 ft. x 170 ft.)

## Results

### System Volume and Bed Size

<b>Installed Storage Volume:</b>	32352.29 cubic ft.
<b>Storage Volume Per Chamber:</b>	175.90 cubic ft.
<b>Number Of Chambers Required:</b>	111
<b>Number Of End Caps Required:</b>	10
<b>Chamber Rows:</b>	5
<b>Maximum Length:</b>	163.56 ft.
<b>Maximum Width:</b>	47.27 ft.
<b>Approx. Bed Size Required:</b>	7555.69 square ft.

### System Components

<b>Amount Of Stone Required:</b>	1152 cubic yards
<b>Volume Of Excavation (Not Including Fill):</b>	1889 cubic yards
<b>Total Non-woven Geotextile Required:</b>	2402 square yards
<b>Woven Geotextile Required (excluding Isolator Row):</b>	85 square yards
<b>Woven Geotextile Required (Isolator Row):</b>	367 square yards
<b>Total Woven Geotextile Required:</b>	452 square yards

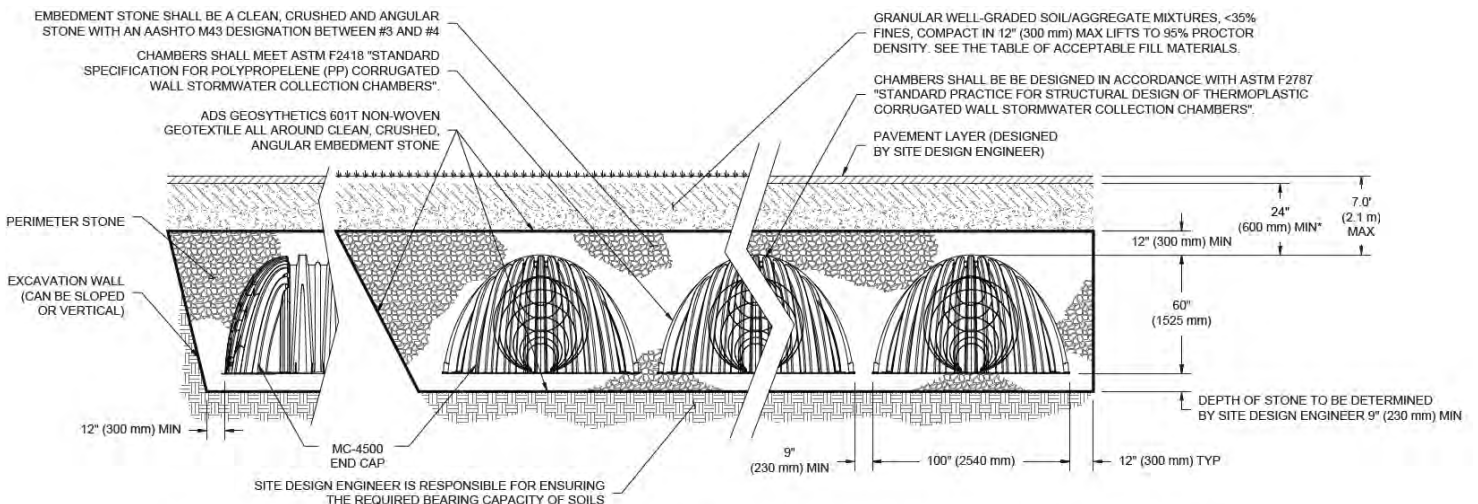

\*MINIMUM COVER TO BOTTOM OF FLEXIBLE PAVEMENT. FOR UNPAVED INSTALLATIONS WHERE RUTTING FROM VEHICLES MAY OCCUR, INCREASE COVER TO 30" (750 mm).

SITE SPECIFIC DATA			
PROJECT NUMBER			
PROJECT NAME			
PROJECT LOCATION			
STRUCTURE ID			
TREATMENT REQUIRED			
VOLUME BASED (CF)		FLOW BASED (CFS)	
N/A			
PEAK BYPASS REQUIRED (CFS) – IF APPLICABLE			
PIPE DATA	I.E.	MATERIAL	DIAMETER
INLET PIPE 1			
INLET PIPE 2			
OUTLET PIPE			
	PRETREATMENT	BIOFILTRATION	DISCHARGE
RIM ELEVATION			
SURFACE LOAD			
FRAME & COVER	2EA $\phi 30"$		$\phi 24"$
NOTES:			

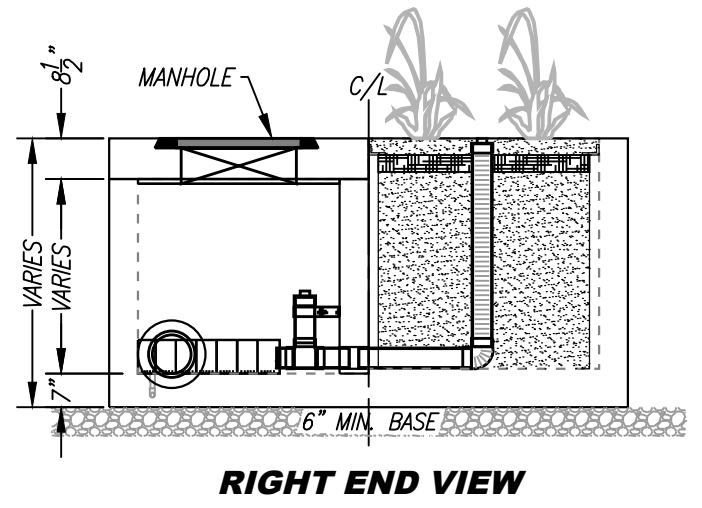
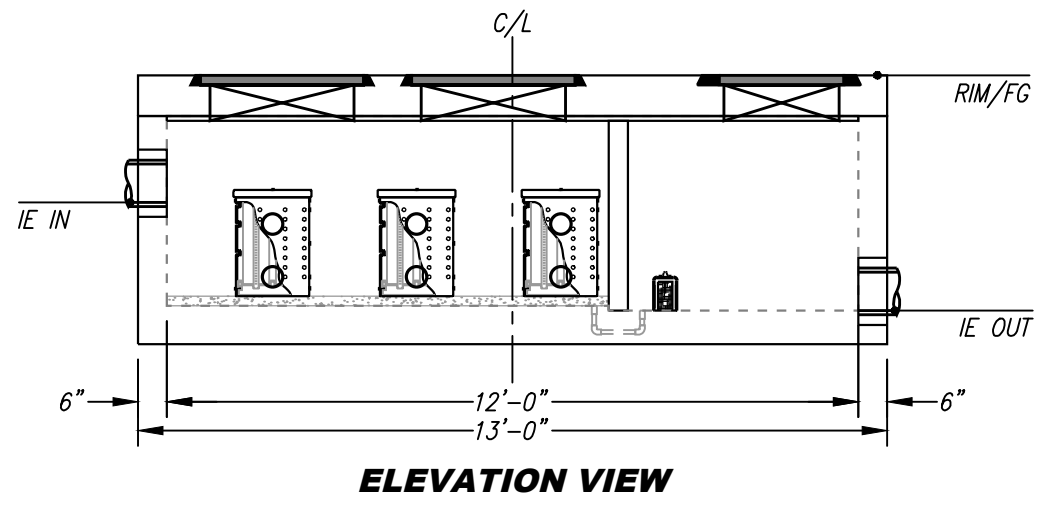
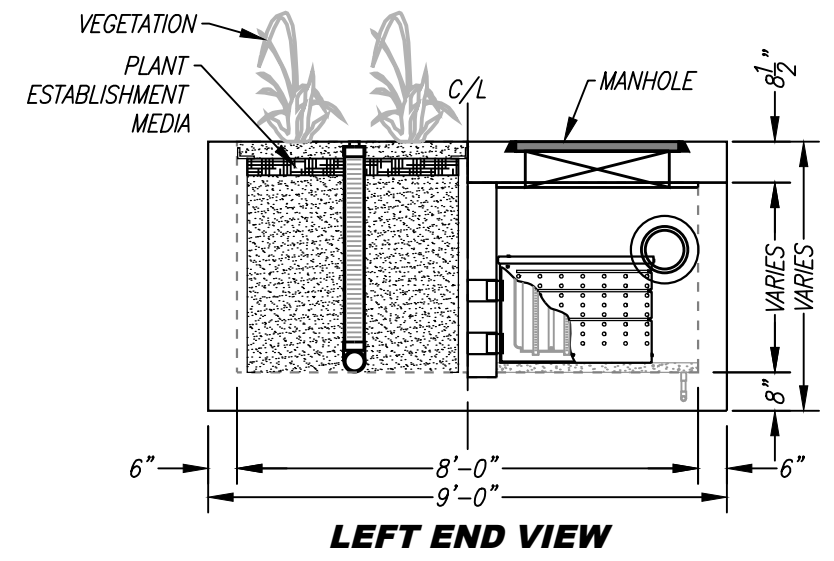
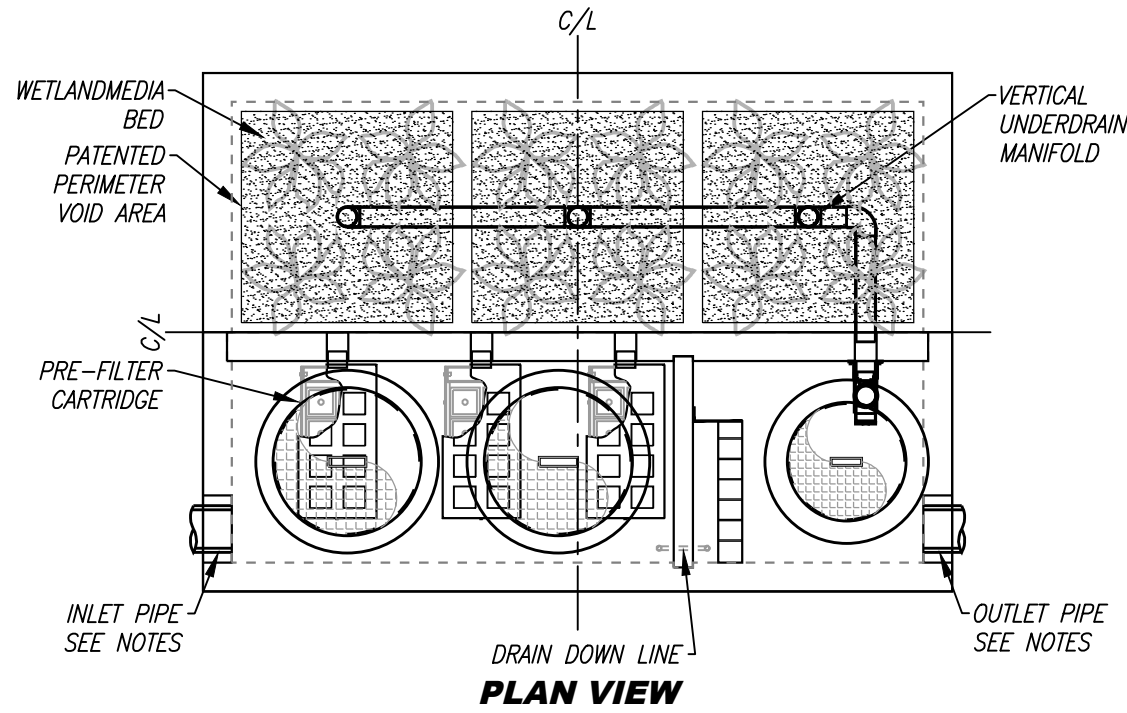

**INSTALLATION NOTES**

1. CONTRACTOR TO PROVIDE ALL LABOR, EQUIPMENT, MATERIALS AND INCIDENTALS REQUIRED TO OFFLOAD AND INSTALL THE SYSTEM AND APPURTENANCES IN ACCORDANCE WITH THIS DRAWING AND THE MANUFACTURERS SPECIFICATIONS, UNLESS OTHERWISE STATED IN MANUFACTURERS CONTRACT.
2. UNIT MUST BE INSTALLED ON LEVEL BASE. MANUFACTURER RECOMMENDS A MINIMUM 6" LEVEL ROCK BASE UNLESS SPECIFIED BY THE PROJECT ENGINEER. CONTRACTOR IS RESPONSIBLE TO VERIFY PROJECT ENGINEERS RECOMMENDED BASE SPECIFICATIONS.
4. CONTRACTOR TO SUPPLY AND INSTALL ALL EXTERNAL CONNECTING PIPES. ALL PIPES MUST BE FLUSH WITH INSIDE SURFACE OF CONCRETE. (PIPES CANNOT INTRUDE BEYOND FLUSH). INVERT OF OUTFLOW PIPE MUST BE FLUSH WITH DISCHARGE CHAMBER FLOOR. ALL PIPES SHALL BE SEALED WATER TIGHT PER MANUFACTURERS STANDARD CONNECTION DETAIL.
5. CONTRACTOR RESPONSIBLE FOR INSTALLATION OF ALL RISERS, MANHOLES, AND HATCHES. CONTRACTOR TO GROUT ALL MANHOLES AND HATCHES TO MATCH FINISHED SURFACE UNLESS SPECIFIED OTHERWISE.
6. VEGETATION SUPPLIED AND INSTALLED BY OTHERS. ALL UNITS WITH VEGETATION MUST HAVE DRIP OR SPRAY IRRIGATION SUPPLIED AND INSTALLED BY OTHERS.
7. CONTRACTOR RESPONSIBLE FOR CONTACTING BIO CLEAN FOR ACTIVATION OF UNIT. MANUFACTURERS WARRANTY IS VOID WITH OUT PROPER ACTIVATION BY A BIO CLEAN REPRESENTATIVE.

**GENERAL NOTES**

1. MANUFACTURER TO PROVIDE ALL MATERIALS UNLESS OTHERWISE NOTED.
2. ALL DIMENSIONS, ELEVATIONS, SPECIFICATIONS AND CAPACITIES ARE SUBJECT TO CHANGE. FOR PROJECT SPECIFIC DRAWINGS DETAILING EXACT DIMENSIONS, WEIGHTS AND ACCESSORIES PLEASE CONTACT BIO CLEAN.

TREATMENT FLOW (CFS)	
OPERATING HEAD (FT)	
PRETREATMENT LOADING RATE (GPM/SF)	
WETLAND MEDIA LOADING RATE (GPM/SF)	



PROPRIETARY AND CONFIDENTIAL:  
 THE INFORMATION CONTAINED IN THIS DOCUMENT IS THE SOLE PROPERTY OF FORTERRA AND ITS COMPANIES. THIS DOCUMENT, NOR ANY PART THEREOF, MAY BE USED, REPRODUCED OR MODIFIED IN ANY MANNER WITH OUT THE WRITTEN CONSENT OF FORTERRA.



**MWS-L-8-12-V**  
**STORMWATER BIOFILTRATION SYSTEM**  
**STANDARD DETAIL**

5/23/19TOLF

SITE SPECIFIC DATA			
PROJECT NUMBER			
PROJECT NAME			
PROJECT LOCATION			
STRUCTURE ID			
TREATMENT REQUIRED			
VOLUME BASED (CF)		FLOW BASED (CFS)	
N/A			
PEAK BYPASS REQUIRED (CFS) – IF APPLICABLE			
PIPE DATA	I.E.	MATERIAL	DIAMETER
INLET PIPE 1			
INLET PIPE 2			
OUTLET PIPE			
	PRETREATMENT	BIOFILTRATION	DISCHARGE
RIM ELEVATION			
SURFACE LOAD			
FRAME & COVER	2EA $\phi 30"$		$\phi 24"$
NOTES:			

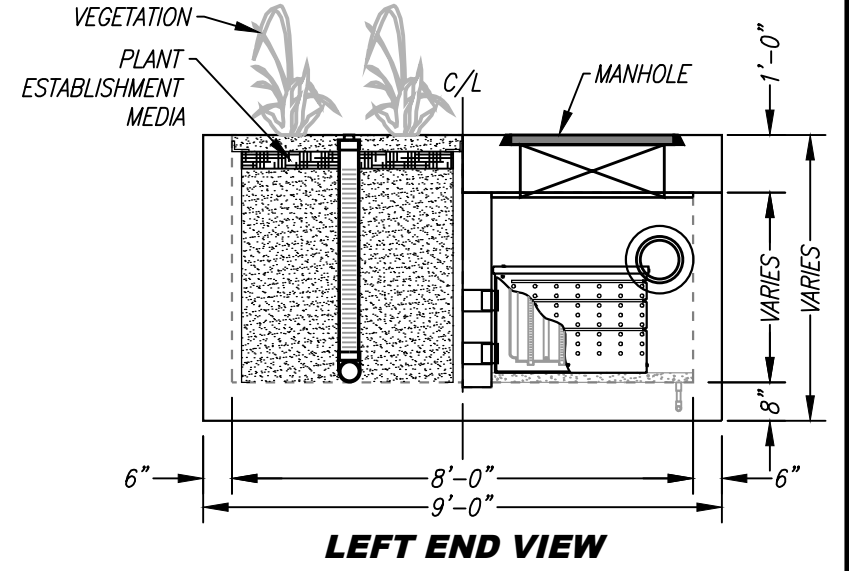
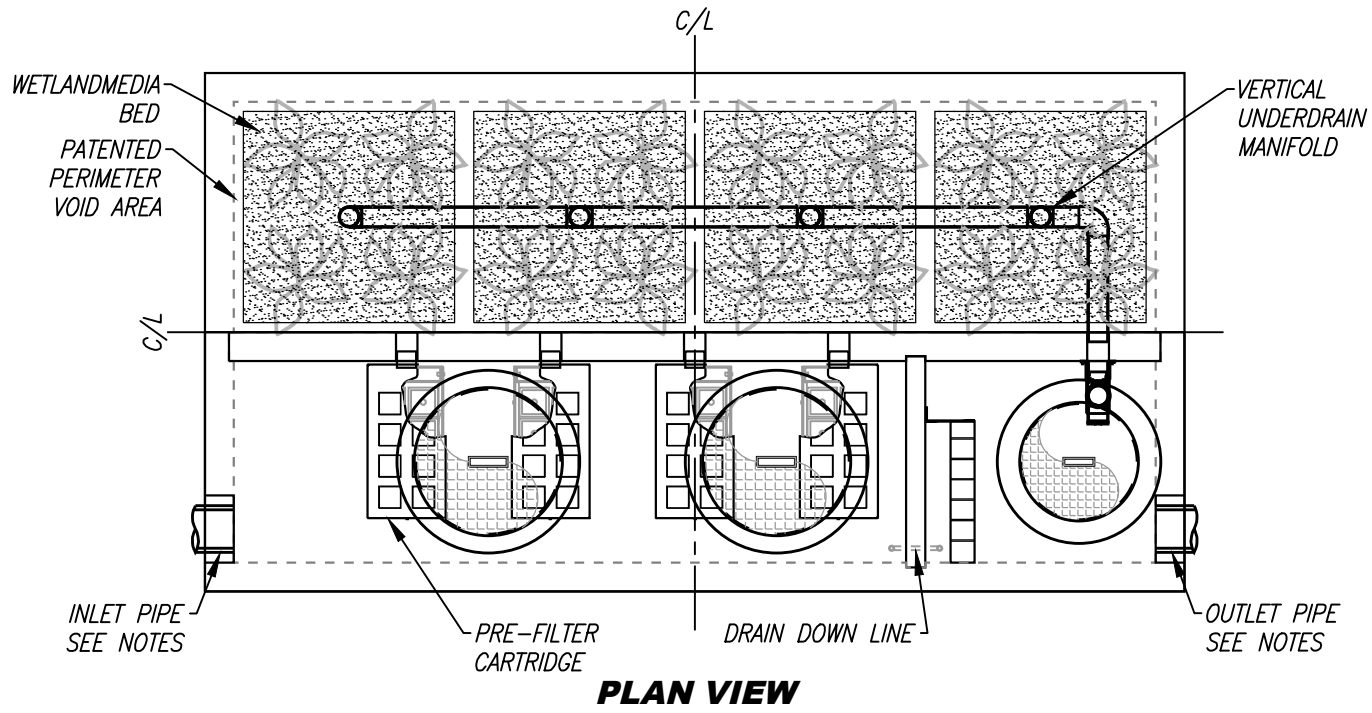

**INSTALLATION NOTES**

1. CONTRACTOR TO PROVIDE ALL LABOR, EQUIPMENT, MATERIALS AND INCIDENTALS REQUIRED TO OFFLOAD AND INSTALL THE SYSTEM AND APPURTENANCES IN ACCORDANCE WITH THIS DRAWING AND THE MANUFACTURERS SPECIFICATIONS, UNLESS OTHERWISE STATED IN MANUFACTURERS CONTRACT.
2. UNIT MUST BE INSTALLED ON LEVEL BASE. MANUFACTURER RECOMMENDS A MINIMUM 6" LEVEL ROCK BASE UNLESS SPECIFIED BY THE PROJECT ENGINEER. CONTRACTOR IS RESPONSIBLE TO VERIFY PROJECT ENGINEERS RECOMMENDED BASE SPECIFICATIONS.
4. CONTRACTOR TO SUPPLY AND INSTALL ALL EXTERNAL CONNECTING PIPES. ALL PIPES MUST BE FLUSH WITH INSIDE SURFACE OF CONCRETE. (PIPES CANNOT INTRUDE BEYOND FLUSH). INVERT OF OUTFLOW PIPE MUST BE FLUSH WITH DISCHARGE CHAMBER FLOOR. ALL PIPES SHALL BE SEALED WATER TIGHT PER MANUFACTURERS STANDARD CONNECTION DETAIL.
5. CONTRACTOR RESPONSIBLE FOR INSTALLATION OF ALL RISERS, MANHOLES, AND HATCHES. CONTRACTOR TO GROUT ALL MANHOLES AND HATCHES TO MATCH FINISHED SURFACE UNLESS SPECIFIED OTHERWISE.
6. VEGETATION SUPPLIED AND INSTALLED BY OTHERS. ALL UNITS WITH VEGETATION MUST HAVE DRIP OR SPRAY IRRIGATION SUPPLIED AND INSTALLED BY OTHERS.
7. CONTRACTOR RESPONSIBLE FOR CONTACTING BIO CLEAN FOR ACTIVATION OF UNIT. MANUFACTURERS WARRANTY IS VOID WITH OUT PROPER ACTIVATION BY A BIO CLEAN REPRESENTATIVE.

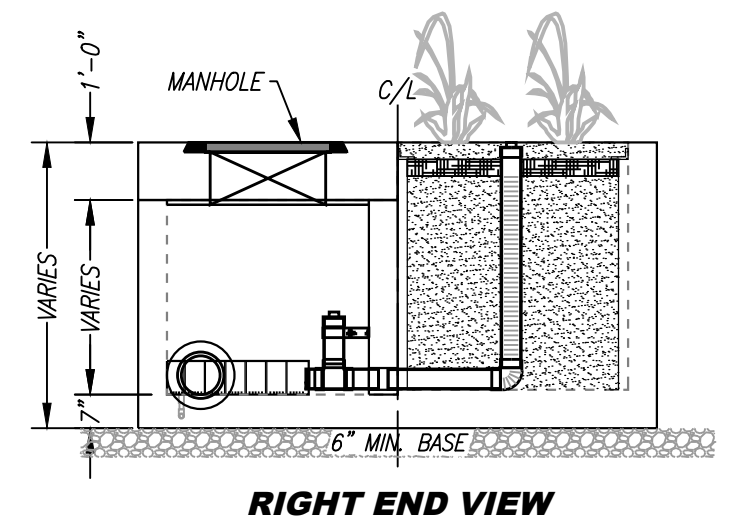
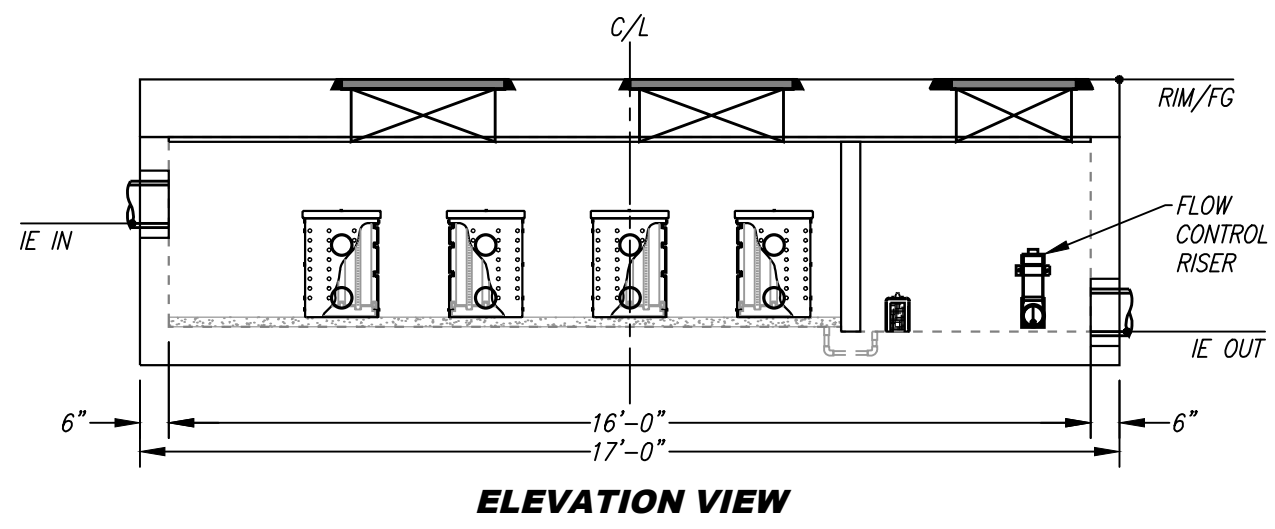

**GENERAL NOTES**

1. MANUFACTURER TO PROVIDE ALL MATERIALS UNLESS OTHERWISE NOTED.
2. ALL DIMENSIONS, ELEVATIONS, SPECIFICATIONS AND CAPACITIES ARE SUBJECT TO CHANGE. FOR PROJECT SPECIFIC DRAWINGS DETAILING EXACT DIMENSIONS, WEIGHTS AND ACCESSORIES PLEASE CONTACT BIO CLEAN.

TREATMENT FLOW (CFS)	
OPERATING HEAD (FT)	
PRETREATMENT LOADING RATE (GPM/SF)	
WETLAND MEDIA LOADING RATE (GPM/SF)	



PROPRIETARY AND CONFIDENTIAL:  
THE INFORMATION CONTAINED IN THIS DOCUMENT IS THE SOLE PROPERTY OF FORTERRA AND ITS COMPANIES. THIS DOCUMENT, NOR ANY PART THEREOF, MAY BE USED, REPRODUCED OR MODIFIED IN ANY MANNER WITH OUT THE WRITTEN CONSENT OF FORTERRA.



**MWS-L-8-16-V**  
**STORMWATER BIOFILTRATION SYSTEM**  
**STANDARD DETAIL**

5/23/19TOLF

SITE SPECIFIC DATA			
PROJECT NUMBER			
PROJECT NAME			
PROJECT LOCATION			
STRUCTURE ID			
TREATMENT REQUIRED			
VOLUME BASED (CF)		FLOW BASED (CFS)	
N/A			
PEAK BYPASS REQUIRED (CFS) – IF APPLICABLE			
PIPE DATA	I.E.	MATERIAL	DIAMETER
INLET PIPE 1			
INLET PIPE 2			
OUTLET PIPE			
	PRETREATMENT	BIOFILTRATION	DISCHARGE
RIM ELEVATION			
SURFACE LOAD			
FRAME & COVER	3EA Ø30"		2EA Ø24"
NOTES:			

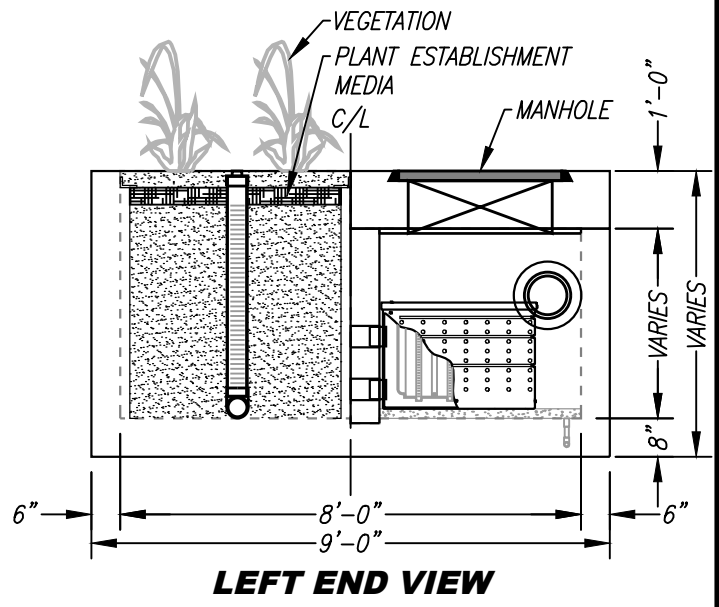
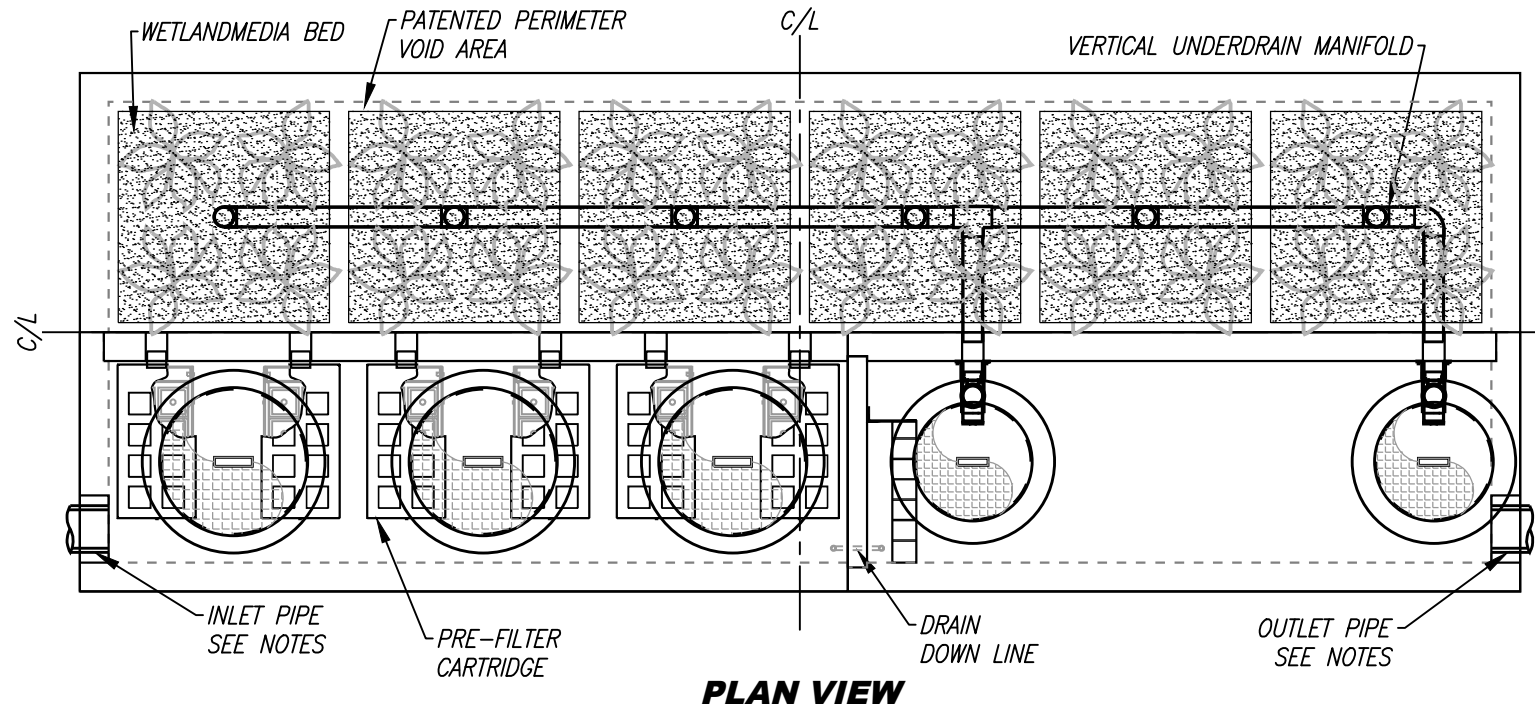

**INSTALLATION NOTES**

1. CONTRACTOR TO PROVIDE ALL LABOR, EQUIPMENT, MATERIALS AND INCIDENTALS REQUIRED TO OFFLOAD AND INSTALL THE SYSTEM AND APPURTENANCES IN ACCORDANCE WITH THIS DRAWING AND THE MANUFACTURERS SPECIFICATIONS, UNLESS OTHERWISE STATED IN MANUFACTURERS CONTRACT.
2. UNIT MUST BE INSTALLED ON LEVEL BASE. MANUFACTURER RECOMMENDS A MINIMUM 6" LEVEL ROCK BASE UNLESS SPECIFIED BY THE PROJECT ENGINEER. CONTRACTOR IS RESPONSIBLE TO VERIFY PROJECT ENGINEERS RECOMMENDED BASE SPECIFICATIONS.
4. CONTRACTOR TO SUPPLY AND INSTALL ALL EXTERNAL CONNECTING PIPES. ALL PIPES MUST BE FLUSH WITH INSIDE SURFACE OF CONCRETE. (PIPES CANNOT INTRUDE BEYOND FLUSH). INVERT OF OUTFLOW PIPE MUST BE FLUSH WITH DISCHARGE CHAMBER FLOOR. ALL PIPES SHALL BE SEALED WATER TIGHT PER MANUFACTURERS STANDARD CONNECTION DETAIL.
5. CONTRACTOR RESPONSIBLE FOR INSTALLATION OF ALL RISERS, MANHOLES, AND HATCHES. CONTRACTOR TO GROUT ALL MANHOLES AND HATCHES TO MATCH FINISHED SURFACE UNLESS SPECIFIED OTHERWISE.
6. VEGETATION SUPPLIED AND INSTALLED BY OTHERS. ALL UNITS WITH VEGETATION MUST HAVE DRIP OR SPRAY IRRIGATION SUPPLIED AND INSTALLED BY OTHERS.
7. CONTRACTOR RESPONSIBLE FOR CONTACTING BIO CLEAN FOR ACTIVATION OF UNIT. MANUFACTURERS WARRANTY IS VOID WITH OUT PROPER ACTIVATION BY A BIO CLEAN REPRESENTATIVE.

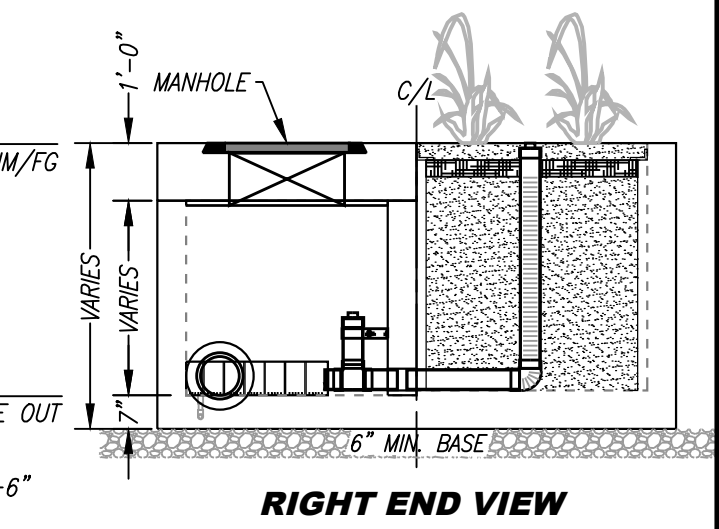
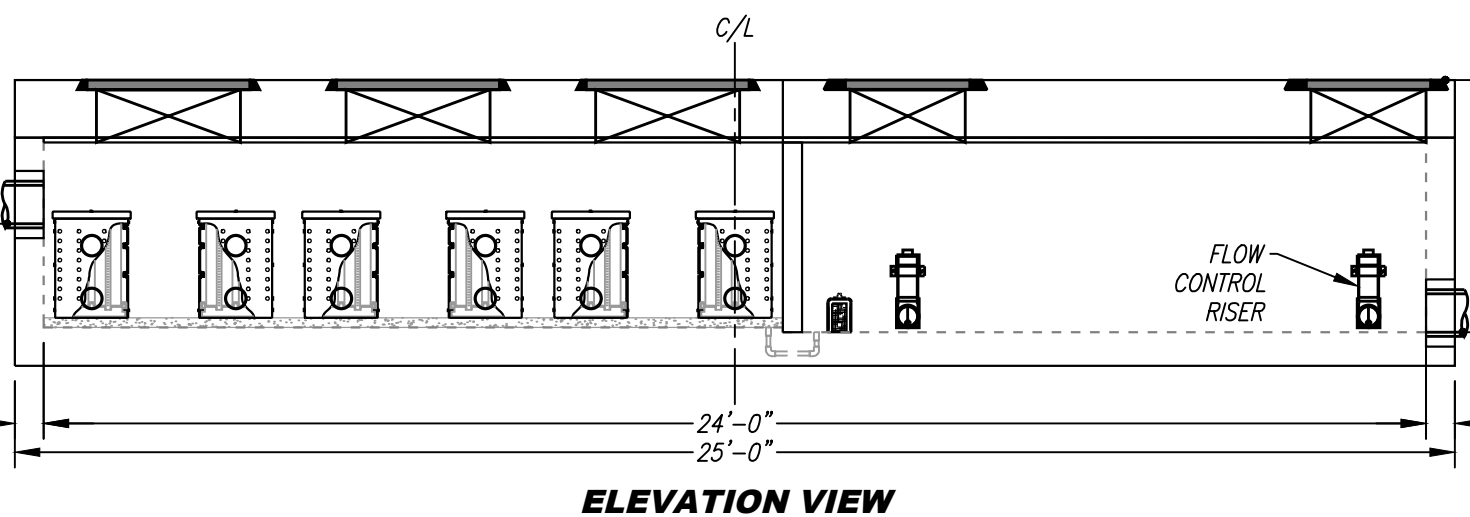

**GENERAL NOTES**

1. MANUFACTURER TO PROVIDE ALL MATERIALS UNLESS OTHERWISE NOTED.
2. ALL DIMENSIONS, ELEVATIONS, SPECIFICATIONS AND CAPACITIES ARE SUBJECT TO CHANGE. FOR PROJECT SPECIFIC DRAWINGS DETAILING EXACT DIMENSIONS, WEIGHTS AND ACCESSORIES PLEASE CONTACT BIO CLEAN.



PROPRIETARY AND CONFIDENTIAL:  
 THE INFORMATION CONTAINED IN THIS DOCUMENT IS THE SOLE PROPERTY OF FORTERRA AND ITS COMPANIES. THIS DOCUMENT, NOR ANY PART THEREOF, MAY BE USED, REPRODUCED OR MODIFIED IN ANY MANNER WITH OUT THE WRITTEN CONSENT OF FORTERRA.



TREATMENT FLOW (CFS)	
OPERATING HEAD (FT)	
PRETREATMENT LOADING RATE (GPM/SF)	
WETLAND MEDIA LOADING RATE (GPM/SF)	

**MWS-L-8-24-V**  
**STORMWATER BIOFILTRATION SYSTEM**  
**STANDARD DETAIL**

5/23/19TOL/EE

# Appendix 7: Hydromodification

*Supporting Detail Relating to Hydrologic Conditions of Concern*

EXEMPT

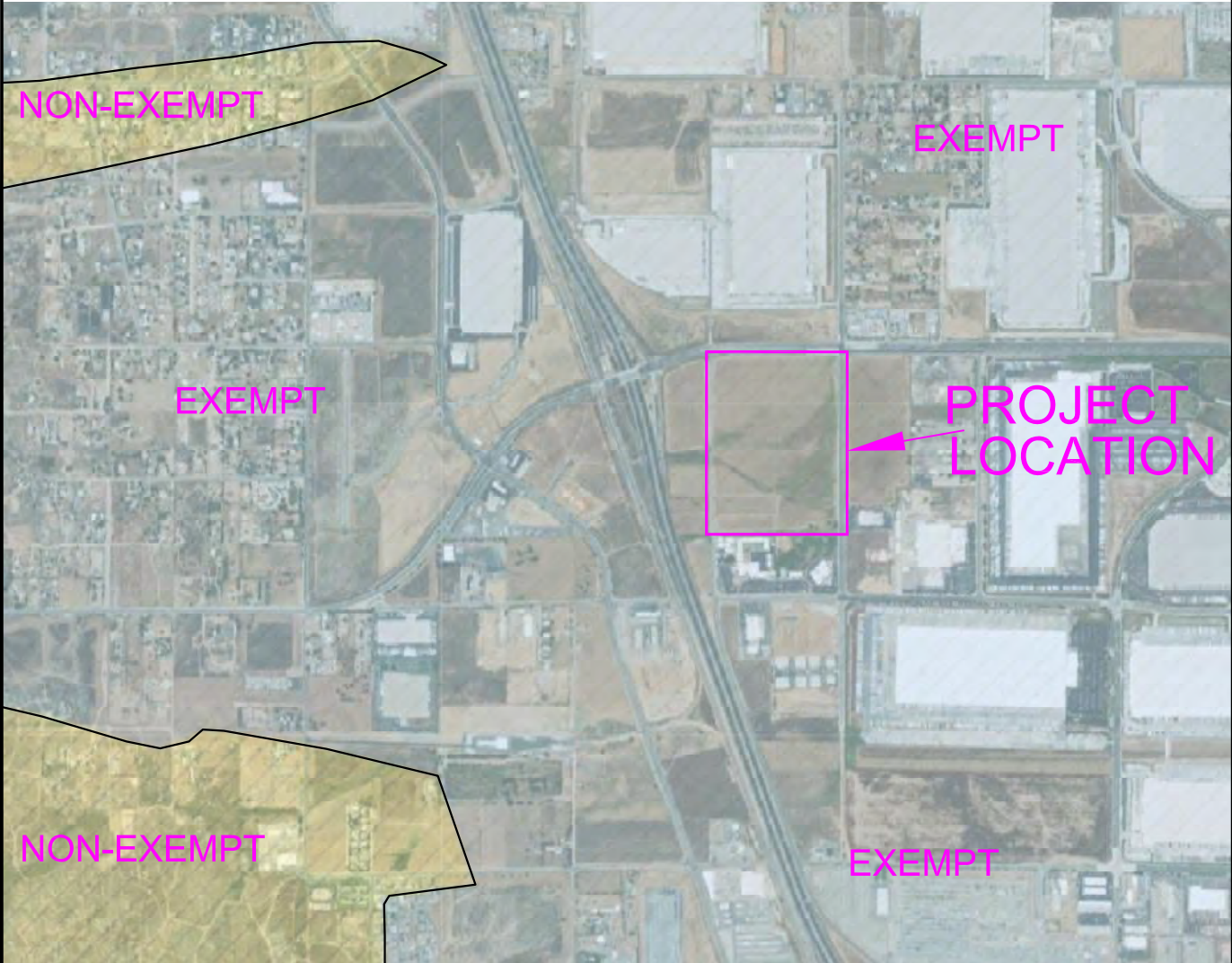

HCOC EXEMPTION AREA MAP



# Appendix 8: Source Control

*Pollutant Sources/Source Control Checklist*

## STORMWATER POLLUTANT SOURCES/SOURCE CONTROL CHECKLIST

**How to use this worksheet (also see instructions in Section G of the WQMP Template):**

1. Review Column 1 and identify which of these potential sources of stormwater pollutants apply to your site. Check each box that applies.
2. Review Column 2 and incorporate all of the corresponding applicable BMPs in your WQMP Exhibit.
3. Review Columns 3 and 4 and incorporate all of the corresponding applicable permanent controls and operational BMPs in your WQMP. Use the format shown in Table G.1 on page 23 of this WQMP Template. Describe your specific BMPs in an accompanying narrative, and explain any special conditions or situations that required omitting BMPs or substituting alternative BMPs for those shown here.

IF THESE SOURCES WILL BE ON THE PROJECT SITE ...	... THEN YOUR WQMP SHOULD INCLUDE THESE SOURCE CONTROL BMPs, AS APPLICABLE		
1 Potential Sources of Runoff Pollutants	2 Permanent Controls—Show on WQMP Drawings	3 Permanent Controls—List in WQMP Table and Narrative	4 Operational BMPs—Include in WQMP Table and Narrative
<input checked="" type="checkbox"/> <b>A. On-site storm drain inlets</b>	<input type="checkbox"/> Locations of inlets.	<input type="checkbox"/> Mark all inlets with the words “Only Rain Down the Storm Drain” or similar. Catch Basin Markers may be available from the Riverside County Flood Control and Water Conservation District, call 951.955.1200 to verify.	<input type="checkbox"/> Maintain and periodically repaint or replace inlet markings. <input type="checkbox"/> Provide stormwater pollution prevention information to new site owners, lessees, or operators. <input type="checkbox"/> See applicable operational BMPs in Fact Sheet SC-44, “Drainage System Maintenance,” in the CASQA Stormwater Quality Handbooks at <a href="http://www.cabmphandbooks.com">www.cabmphandbooks.com</a> <input type="checkbox"/> Include the following in lease agreements: “Tenant shall not allow anyone to discharge anything to storm drains or to store or deposit materials so as to create a potential discharge to storm drains.”
<input type="checkbox"/> <b>B. Interior floor drains and elevator shaft sump pumps</b>		<input type="checkbox"/> State that interior floor drains and elevator shaft sump pumps will be plumbed to sanitary sewer.	<input type="checkbox"/> Inspect and maintain drains to prevent blockages and overflow.
<input type="checkbox"/> <b>C. Interior parking garages</b>		<input type="checkbox"/> State that parking garage floor drains will be plumbed to the sanitary sewer.	<input type="checkbox"/> Inspect and maintain drains to prevent blockages and overflow.

**STORMWATER POLLUTANT SOURCES/SOURCE CONTROL CHECKLIST**

IF THESE SOURCES WILL BE ON THE PROJECT SITE ...	... THEN YOUR WQMP SHOULD INCLUDE THESE SOURCE CONTROL BMPs, AS APPLICABLE		
1 Potential Sources of Runoff Pollutants	2 Permanent Controls—Show on WQMP Drawings	3 Permanent Controls—List in WQMP Table and Narrative	4 Operational BMPs—Include in WQMP Table and Narrative
<input type="checkbox"/> <b>D1.</b> Need for future indoor & structural pest control		<input type="checkbox"/> Note building design features that discourage entry of pests.	<input type="checkbox"/> Provide Integrated Pest Management information to owners, lessees, and operators.
<input checked="" type="checkbox"/> <b>D2.</b> Landscape/ Outdoor Pesticide Use	<input type="checkbox"/> Show locations of native trees or areas of shrubs and ground cover to be undisturbed and retained. <input type="checkbox"/> Show self-retaining landscape areas, if any. <input type="checkbox"/> Show stormwater treatment and hydrograph modification management BMPs. (See instructions in Chapter 3, Step 5 and guidance in Chapter 5.)	<p>State that final landscape plans will accomplish all of the following.</p> <input type="checkbox"/> Preserve existing native trees, shrubs, and ground cover to the maximum extent possible. <input type="checkbox"/> Design landscaping to minimize irrigation and runoff, to promote surface infiltration where appropriate, and to minimize the use of fertilizers and pesticides that can contribute to stormwater pollution. <input type="checkbox"/> Where landscaped areas are used to retain or detain stormwater, specify plants that are tolerant of saturated soil conditions. <input type="checkbox"/> Consider using pest-resistant plants, especially adjacent to hardscape. <p>To insure successful establishment, select plants appropriate to site soils, slopes, climate, sun, wind, rain, land use, air movement, ecological consistency, and plant interactions.</p>	<input type="checkbox"/> Maintain landscaping using minimum or no pesticides. <input type="checkbox"/> See applicable operational BMPs in “What you should know for.....Landscape and Gardening” at <a href="http://rcflood.org/stormwater/Error!">http://rcflood.org/stormwater/Error!</a> Hyperlink reference not valid. <input type="checkbox"/> Provide IPM information to new owners, lessees and operators.

**STORMWATER POLLUTANT SOURCES/SOURCE CONTROL CHECKLIST**

IF THESE SOURCES WILL BE ON THE PROJECT SITE ...	... THEN YOUR WQMP SHOULD INCLUDE THESE SOURCE CONTROL BMPs, AS APPLICABLE		
1 Potential Sources of Runoff Pollutants	2 Permanent Controls—Show on WQMP Drawings	3 Permanent Controls—List in WQMP Table and Narrative	4 Operational BMPs—Include in WQMP Table and Narrative
<input type="checkbox"/> <b>E.</b> Pools, spas, ponds, decorative fountains, and other water features.	<input type="checkbox"/> Show location of water feature and a sanitary sewer cleanout in an accessible area within 10 feet. (Exception: Public pools must be plumbed according to County Department of Environmental Health Guidelines.)	If the Co-Permittee requires pools to be plumbed to the sanitary sewer, place a note on the plans and state in the narrative that this connection will be made according to local requirements.	<input type="checkbox"/> See applicable operational BMPs in "Guidelines for Maintaining Your Swimming Pool, Jacuzzi and Garden Fountain" at <a href="http://rcflood.org/stormwater/">http://rcflood.org/stormwater/</a>
<input type="checkbox"/> <b>F.</b> Food service	<input type="checkbox"/> For restaurants, grocery stores, and other food service operations, show location (indoors or in a covered area outdoors) of a floor sink or other area for cleaning floor mats, containers, and equipment.  <input type="checkbox"/> On the drawing, show a note that this drain will be connected to a grease interceptor before discharging to the sanitary sewer.	<input type="checkbox"/> Describe the location and features of the designated cleaning area.  <input type="checkbox"/> Describe the items to be cleaned in this facility and how it has been sized to insure that the largest items can be accommodated.	<input type="checkbox"/> See the brochure, "The Food Service Industry Best Management Practices for: Restaurants, Grocery Stores, Delicatessens and Bakeries" at <a href="http://rcflood.org/stormwater/">http://rcflood.org/stormwater/</a>  <b>Provide this brochure to new site owners, lessees, and operators.</b>
<input checked="" type="checkbox"/> <b>G.</b> Refuse areas	<input type="checkbox"/> Show where site refuse and recycled materials will be handled and stored for pickup. See local municipal requirements for sizes and other details of refuse areas.  <input type="checkbox"/> If dumpsters or other receptacles are outdoors, show how the designated area will be covered, graded, and paved to prevent run-on and show locations of berms to prevent runoff from the area.  <input type="checkbox"/> Any drains from dumpsters, compactors, and tallow bin areas shall be connected to a grease removal device before discharge to sanitary sewer.	<input type="checkbox"/> State how site refuse will be handled and provide supporting detail to what is shown on plans.  <input type="checkbox"/> State that signs will be posted on or near dumpsters with the words "Do not dump hazardous materials here" or similar.	<input type="checkbox"/> State how the following will be implemented:  <b>Provide adequate number of receptacles. Inspect receptacles regularly; repair or replace leaky receptacles. Keep receptacles covered. Prohibit/prevent dumping of liquid or hazardous wastes. Post "no hazardous materials" signs. Inspect and pick up litter daily and clean up spills immediately. Keep spill control materials available on-site. See Fact Sheet SC-34, "Waste Handling and Disposal" in the CASQA Stormwater Quality Handbooks at <a href="http://www.cabmphandbooks.com">www.cabmphandbooks.com</a></b>

**STORMWATER POLLUTANT SOURCES/SOURCE CONTROL CHECKLIST**

IF THESE SOURCES WILL BE ON THE PROJECT SITE ...	... THEN YOUR WQMP SHOULD INCLUDE THESE SOURCE CONTROL BMPs, AS APPLICABLE		
1 Potential Sources of Runoff Pollutants	2 Permanent Controls—Show on WQMP Drawings	3 Permanent Controls—List in WQMP Table and Narrative	4 Operational BMPs—Include in WQMP Table and Narrative
<input type="checkbox"/> H. Industrial processes.	<input type="checkbox"/> Show process area.	<input type="checkbox"/> If industrial processes are to be located on site, state: “All process activities to be performed indoors. No processes to drain to exterior or to storm drain system.”	<input type="checkbox"/> See Fact Sheet SC-10, “Non-Stormwater Discharges” in the CASQA Stormwater Quality Handbooks at <a href="http://www.cabmphandbooks.com">www.cabmphandbooks.com</a>  See the brochure “Industrial & Commercial Facilities Best Management Practices for: Industrial, Commercial Facilities” at <a href="http://rcflood.org/stormwater/">http://rcflood.org/stormwater/</a>

**STORMWATER POLLUTANT SOURCES/SOURCE CONTROL CHECKLIST**

IF THESE SOURCES WILL BE ON THE PROJECT SITE ...	... THEN YOUR WQMP SHOULD INCLUDE THESE SOURCE CONTROL BMPs, AS APPLICABLE		
1 Potential Sources of Runoff Pollutants	2 Permanent Controls—Show on WQMP Drawings	3 Permanent Controls—List in WQMP Table and Narrative	4 Operational BMPs—Include in WQMP Table and Narrative
<input type="checkbox"/> I. Outdoor storage of equipment or materials. (See rows J and K for source control measures for vehicle cleaning, repair, and maintenance.)	<input type="checkbox"/> Show any outdoor storage areas, including how materials will be covered. Show how areas will be graded and bermed to prevent run-on or run-off from area.  <input type="checkbox"/> Storage of non-hazardous liquids shall be covered by a roof and/or drain to the sanitary sewer system, and be contained by berms, dikes, liners, or vaults.  <input type="checkbox"/> Storage of hazardous materials and wastes must be in compliance with the local hazardous materials ordinance and a Hazardous Materials Management Plan for the site.	<p>Include a detailed description of materials to be stored, storage areas, and structural features to prevent pollutants from entering storm drains.</p> <p>Where appropriate, reference documentation of compliance with the requirements of Hazardous Materials Programs for:</p> <ul style="list-style-type: none"> <li>▪ Hazardous Waste Generation</li> <li>▪ Hazardous Materials Release Response and Inventory</li> <li>▪ California Accidental Release (CalARP)</li> <li>▪ Aboveground Storage Tank</li> <li>▪ Uniform Fire Code Article 80 Section 103(b) &amp; (c) 1991</li> <li>▪ Underground Storage Tank</li> </ul> <p><a href="http://www.cchealth.org/groups/hazmat/">www.cchealth.org/groups/hazmat/</a></p>	<input type="checkbox"/> See the Fact Sheets SC-31, “Outdoor Liquid Container Storage” and SC-33, “Outdoor Storage of Raw Materials ” in the CASQA Stormwater Quality Handbooks at <a href="http://www.cabmphandbooks.com">www.cabmphandbooks.com</a>

**STORMWATER POLLUTANT SOURCES/SOURCE CONTROL CHECKLIST**

IF THESE SOURCES WILL BE ON THE PROJECT SITE ...	... THEN YOUR WQMP SHOULD INCLUDE THESE SOURCE CONTROL BMPs, AS APPLICABLE		
1 Potential Sources of Runoff Pollutants	2 Permanent Controls—Show on WQMP Drawings	3 Permanent Controls—List in WQMP Table and Narrative	4 Operational BMPs—Include in WQMP Table and Narrative
<input checked="" type="checkbox"/> <b>J. Vehicle and Equipment Cleaning</b>	<input type="checkbox"/> Show on drawings as appropriate: (1) Commercial/industrial facilities having vehicle/equipment cleaning needs shall either provide a covered, bermed area for washing activities or discourage vehicle/equipment washing by removing hose bibs and installing signs prohibiting such uses. (2) Multi-dwelling complexes shall have a paved, bermed, and covered car wash area (unless car washing is prohibited on-site and hoses are provided with an automatic shut-off to discourage such use). (3) Washing areas for cars, vehicles, and equipment shall be paved, designed to prevent run-on to or runoff from the area, and plumbed to drain to the sanitary sewer. (4) Commercial car wash facilities shall be designed such that no runoff from the facility is discharged to the storm drain system. Wastewater from the facility shall discharge to the sanitary sewer, or a wastewater reclamation system shall be installed.	<input type="checkbox"/> If a car wash area is not provided, describe any measures taken to discourage on-site car washing and explain how these will be enforced.	Describe operational measures to implement the following (if applicable): <input type="checkbox"/> Washwater from vehicle and equipment washing operations shall not be discharged to the storm drain system. Refer to “Outdoor Cleaning Activities and Professional Mobile Service Providers” for many of the Potential Sources of Runoff Pollutants categories below. Brochure can be found at <a href="http://rcflood.org/stormwater/">http://rcflood.org/stormwater/</a> <input type="checkbox"/> Car dealerships and similar may rinse cars with water only.

**STORMWATER POLLUTANT SOURCES/SOURCE CONTROL CHECKLIST**

IF THESE SOURCES WILL BE ON THE PROJECT SITE ...	... THEN YOUR WQMP SHOULD INCLUDE THESE SOURCE CONTROL BMPs, AS APPLICABLE		
1 Potential Sources of Runoff Pollutants	2 Permanent Controls—Show on WQMP Drawings	3 Permanent Controls—List in WQMP Table and Narrative	4 Operational BMPs—Include in WQMP Table and Narrative
<input type="checkbox"/> <b>K. Vehicle/Equipment Repair and Maintenance</b>	<input type="checkbox"/> Accommodate all vehicle equipment repair and maintenance indoors. Or designate an outdoor work area and design the area to prevent run-on and runoff of stormwater.  <input type="checkbox"/> Show secondary containment for exterior work areas where motor oil, brake fluid, gasoline, diesel fuel, radiator fluid, acid-containing batteries or other hazardous materials or hazardous wastes are used or stored. Drains shall not be installed within the secondary containment areas.  <input type="checkbox"/> Add a note on the plans that states either (1) there are no floor drains, or (2) floor drains are connected to wastewater pretreatment systems prior to discharge to the sanitary sewer and an industrial waste discharge permit will be obtained.	<input type="checkbox"/> State that no vehicle repair or maintenance will be done outdoors, or else describe the required features of the outdoor work area.  <input type="checkbox"/> State that there are no floor drains or if there are floor drains, note the agency from which an industrial waste discharge permit will be obtained and that the design meets that agency's requirements.  <input type="checkbox"/> State that there are no tanks, containers or sinks to be used for parts cleaning or rinsing or, if there are, note the agency from which an industrial waste discharge permit will be obtained and that the design meets that agency's requirements.	<p>In the Stormwater Control Plan, note that all of the following restrictions apply to use the site:</p> <input type="checkbox"/> No person shall dispose of, nor permit the disposal, directly or indirectly of vehicle fluids, hazardous materials, or rinsewater from parts cleaning into storm drains.  <input type="checkbox"/> No vehicle fluid removal shall be performed outside a building, nor on asphalt or ground surfaces, whether inside or outside a building, except in such a manner as to ensure that any spilled fluid will be in an area of secondary containment. Leaking vehicle fluids shall be contained or drained from the vehicle immediately.  <input type="checkbox"/> No person shall leave unattended drip parts or other open containers containing vehicle fluid, unless such containers are in use or in an area of secondary containment.  Refer to "Automotive Maintenance & Car Care Best Management Practices for Auto Body Shops, Auto Repair Shops, Car Dealerships, Gas Stations and Fleet Service Operations". Brochure can be found at <a href="http://rcflood.org/stormwater/">http://rcflood.org/stormwater/</a>  Refer to Outdoor Cleaning Activities and Professional Mobile Service Providers for many of the Potential Sources of Runoff Pollutants categories below. Brochure can be found at <a href="http://rcflood.org/stormwater/">http://rcflood.org/stormwater/</a>

**STORMWATER POLLUTANT SOURCES/SOURCE CONTROL CHECKLIST**

IF THESE SOURCES WILL BE ON THE PROJECT SITE ...	... THEN YOUR WQMP SHOULD INCLUDE THESE SOURCE CONTROL BMPs, AS APPLICABLE		
1 Potential Sources of Runoff Pollutants	2 Permanent Controls—Show on WQMP Drawings	3 Permanent Controls—List in WQMP Table and Narrative	4 Operational BMPs—Include in WQMP Table and Narrative
<input checked="" type="checkbox"/> L. Fuel Dispensing Areas	<input type="checkbox"/> Fueling areas <sup>6</sup> shall have impermeable floors (i.e., portland cement concrete or equivalent smooth impervious surface) that are: a) graded at the minimum slope necessary to prevent ponding; and b) separated from the rest of the site by a grade break that prevents run-on of stormwater to the maximum extent practicable.  <input type="checkbox"/> Fueling areas shall be covered by a canopy that extends a minimum of ten feet in each direction from each pump. [Alternative: The fueling area must be covered and the cover's minimum dimensions must be equal to or greater than the area within the grade break or fuel dispensing area <sup>1</sup> .] The canopy [or cover] shall not drain onto the fueling area.		<input type="checkbox"/> The property owner shall dry sweep the fueling area routinely. <input type="checkbox"/> See the Fact Sheet SD-30 , “Fueling Areas” in the CASQA Stormwater Quality Handbooks at <a href="http://www.cabmphandbooks.com">www.cabmphandbooks.com</a>

<sup>6</sup> The fueling area shall be defined as the area extending a minimum of 6.5 feet from the corner of each fuel dispenser or the length at which the hose and nozzle assembly may be operated plus a minimum of one foot, whichever is greater.

**STORMWATER POLLUTANT SOURCES/SOURCE CONTROL CHECKLIST**

IF THESE SOURCES WILL BE ON THE PROJECT SITE ...	... THEN YOUR WQMP SHOULD INCLUDE THESE SOURCE CONTROL BMPs, AS APPLICABLE		
1 Potential Sources of Runoff Pollutants	2 Permanent Controls—Show on WQMP Drawings	3 Permanent Controls—List in WQMP Table and Narrative	4 Operational BMPs—Include in WQMP Table and Narrative
<input checked="" type="checkbox"/> M. Loading Docks	<input type="checkbox"/> Show a preliminary design for the loading dock area, including roofing and drainage. Loading docks shall be covered and/or graded to minimize run-on to and runoff from the loading area. Roof downspouts shall be positioned to direct stormwater away from the loading area. Water from loading dock areas shall be drained to the sanitary sewer, or diverted and collected for ultimate discharge to the sanitary sewer.  <input type="checkbox"/> Loading dock areas draining directly to the sanitary sewer shall be equipped with a spill control valve or equivalent device, which shall be kept closed during periods of operation.  <input checked="" type="checkbox"/> Install door skirts (cowling) at each bay that enclose the end of the trailer.		<input type="checkbox"/> Move loaded and unloaded items indoors as soon as possible.  <input type="checkbox"/> See Fact Sheet SC-30, “Outdoor Loading and Unloading,” in the CASQA Stormwater Quality Handbooks at <a href="http://www.cabmphandbooks.com">www.cabmphandbooks.com</a>

**STORMWATER POLLUTANT SOURCES/SOURCE CONTROL CHECKLIST**

IF THESE SOURCES WILL BE ON THE PROJECT SITE ...	... THEN YOUR WQMP SHOULD INCLUDE THESE SOURCE CONTROL BMPs, AS APPLICABLE		
1 Potential Sources of Runoff Pollutants	2 Permanent Controls—Show on WQMP Drawings	3 Permanent Controls—List in WQMP Table and Narrative	4 Operational BMPs—Include in WQMP Table and Narrative
<input type="checkbox"/> <b>N.</b> Fire Sprinkler Test Water		<input type="checkbox"/> Provide a means to drain fire sprinkler test water to the sanitary sewer.	<input type="checkbox"/> See the note in Fact Sheet SC-41, “Building and Grounds Maintenance,” in the CASQA Stormwater Quality Handbooks at <a href="http://www.cabmphandbooks.com">www.cabmphandbooks.com</a>
<p><b>O.</b> Miscellaneous Drain or Wash Water or Other Sources</p> <input type="checkbox"/> Boiler drain lines <input type="checkbox"/> Condensate drain lines <input type="checkbox"/> Rooftop equipment <input type="checkbox"/> Drainage sumps <input type="checkbox"/> Roofing, gutters, and trim. <input type="checkbox"/> Other sources		<input type="checkbox"/> Boiler drain lines shall be directly or indirectly connected to the sanitary sewer system and may not discharge to the storm drain system. <input type="checkbox"/> Condensate drain lines may discharge to landscaped areas if the flow is small enough that runoff will not occur. Condensate drain lines may not discharge to the storm drain system. Rooftop equipment with potential to produce pollutants shall be <input type="checkbox"/> roofed and/or have secondary containment. Any drainage sumps on-site shall <input type="checkbox"/> feature a sediment sump to reduce the quantity of sediment in pumped water. <input type="checkbox"/> Avoid roofing, gutters, and trim made of copper or other unprotected metals that may leach into runoff. Include controls for other sources as specified by local reviewer	

**STORMWATER POLLUTANT SOURCES/SOURCE CONTROL CHECKLIST**

<b>IF THESE SOURCES WILL BE ON THE PROJECT SITE ...</b>	<b>... THEN YOUR WQMP SHOULD INCLUDE THESE SOURCE CONTROL BMPs, AS APPLICABLE</b>		
<b>1 Potential Sources of Runoff Pollutants</b>	<b>2 Permanent Controls—Show on WQMP Drawings</b>	<b>3 Permanent Controls—List in WQMP Table and Narrative</b>	<b>4 Operational BMPs—Include in WQMP Table and Narrative</b>
<input checked="" type="checkbox"/> P. Plazas, sidewalks, and parking lots.			<input type="checkbox"/> Sweep plazas, sidewalks, and parking lots regularly to prevent accumulation of litter and debris. Collect debris from pressure washing to prevent entry into the storm drain system. Collect washwater containing any cleaning agent or degreaser and discharge to the sanitary sewer not to a storm drain.

## Appendix 9: O&M

*Operation and Maintenance Plan and Documentation of Finance, Maintenance and Recording Mechanisms*

**Operation and Maintenance**

**O&M DESCRIPTION AND SCHEDULE:**

Based on the standard Source Control BMPs listed in the WQMP Guidelines, the following chart indicates which Source Control (Non-Structural) BMPs will be implemented at this site.

Note that "OWNER" refers to: *Perris Landco, LLC*

Description of BMP and Method of Implementation	BMP Responsibility	Maintenance Responsibility	Funding Source For O & M	Maintenance Schedule
<p><b><u>Education for Property Owners, Tenants and Occupants:</u></b> The owner shall provide practical information materials: Water Quality Management on general housekeeping practices that contribute to the protection of stormwater quality. The future tenant/occupants will be given educational materials upon move-in and annually thereafter. Educational materials shall be located in the attachments of the WQMP. The owner and future tenant/occupants will be required to familiarize themselves with the WQMP Booklet and agree to abide by and perform maintenance functions.</p> <p>Start up date: Occupancy</p>	<p><b>Owner</b></p>	<p><b>Owner</b></p>	<p><b>Owner</b></p>	<p>Owner shall provide tenant/occupants educational materials upon move-in and annually thereafter. In conformance to the Model WQMP, see Attachments for educational materials.</p>

Description of BMP and Method of Implementation	BMP Responsibility	Maintenance Responsibility	Funding Source For O & M	Maintenance Schedule
<p><b>Activity Restrictions:</b> Use restrictions (Addendum to Lease Agreement) shall be prepared by owner for the tenant/occupants and for the purpose of surface water quality protection. Owner shall enforce prohibitions of conditions, covenants, and restrictions (CC&amp;Rs) and/or Lease Agreement to future tenant/occupants and thereafter. Use restrictions shall be utilized by said tenant/occupants. Additionally, no litter, liquids, or solids of any kind will be allowed to enter the on-site surface water drainage systems. Identified restrictions that will be imposed are as follows: Prohibit hosing down any paved surfaces where the result would be the flow of non-storm water into the street or storm drains, Prohibit dumping of any waste into catch basins, Prohibit blowing or sweeping of debris (leaf litter, grass clippings, litter,) into catch basins or streets, Prohibit discharges of fertilizer, pesticides, to streets or storm drains, Keep dumpster lids closed at all times.</p> <p>Start-up date: At point in time Activity Restrictions are made part of Lease Agreement.</p>	<b>Owner</b>	<b>Owner</b>	<b>Owner</b>	<p>Owner shall provide Activity Restrictions to tenant/occupants upon move-in. Owner shall be responsible to enforce restrictions "indefinitely."</p>
<p><b>Landscape Planning:</b></p> <p>The landscape maintenance contractor shall perform the following on a weekly basis: Mowing, trimming/weeding, pruning and/or planting, and removal of litter, maintenance shall include, but</p>	<b>Owner</b>	<b>Owner</b>	<b>Owner</b>	<p>Owner shall contract with a reputable landscape maintenance contractor. The landscape maintenance contractor shall provide landscape maintenance</p>

Description of BMP and Method of Implementation	BMP Responsibility	Maintenance Responsibility	Funding Source For O & M	Maintenance Schedule
<p>not limited to, support structures. There shall be periodic inspection of the landscape areas to ensure the replacement of dead or diseased dying vegetation, Unhealthy or dead trees shall be replaced within seventy-two (72) hours, and the irrigation system is functioning properly. The landscape maintenance contractor shall utilize properly timed fertilizing and pesticide, weeding, pest control, and pruning, to preserve the landscapes water efficiency. Furthermore, the landscape maintenance contractor shall utilize proper management and their usage on fertilizers and pesticides this includes scheduling and disposal. The landscape maintenance contractor shall utilize landscape waste management (i.e., waste handling and disposal). Erosion control management shall be enforced, the landscape maintenance contractor shall inspect for erodable barren soil, maintain vegetative cover to prevent soil erosion, apply mulch or applicable alternative to serve as additional cover for soil stabilization. The landscape maintenance contractor shall train employees on these BMPs, storm water discharge prohibitions, and wastewater discharge requirements. The landscape maintenance contractor shall educate and train employees on the use of pesticides and pesticide application techniques. Only employees properly trained to use pesticides can apply them. The contractor shall train employees on proper spill containment and cleanup.</p>				<p>experience/training in horticulture, fertilizer and pesticide usage, irrigation system knowledge, waste management, erosion control, storm water discharge prohibition, and wastewater discharge. Furthermore, have a spill contingency plan. Landscape Management shall be performed on a weekly basis.</p>

Description of BMP and Method of Implementation	BMP Responsibility	Maintenance Responsibility	Funding Source For O & M	Maintenance Schedule
<p>Establish a regular training schedule, train all new and future employees, and conduct annual refresher training; furthermore, use a training log or similar method to document training.</p> <p>Start-up date: at time of installation</p>				
<p><b>BMP Maintenance:</b> Owner shall be responsible for <u>implementation</u> of each non-structural BMP and <u>scheduled</u> cleaning, maintenance and repair of all structural/treatment BMP facilities “indefinitely.”</p> <p>Bioretention basin will require:            Remove trash from facility.            Remove sediment from forebay when estimated sediment accumulation exceeds 25% of the forebay volume.            Scrape soil from top 3 to 6 inches of infiltration bed and reestablished vegetation; augment soil amendment if needed.            Check energy dissipation function and add riprap as needed. Keep adjacent landscape areas maintained. Remove clippings from landscape maintenance activities. Replace any damaged or dead plants or grasses.            Inspect areas for ponding after storm events.</p> <p>Start-up date: at time of installation</p>	<b>Owner</b>	<b>Owner</b>	<b>Owner</b>	<p>Owner shall be responsible for the inspection, operation, maintenance and repair of non-structural and structural/treatment facility BMPs, and shall document on the operation and maintenance schedule (log) for the life of the project. Frequency of maintenance shall be ongoing.</p>
<p><b>Litter Control:</b> The owner shall provide trash enclosure to common area(s) to dispose of trash, additionally sidewalks and private parking lots shall be maintained for litter control. The owner shall schedule trash pick-up for disposal of dumpster(s) and free</p>	<b>Owner</b>	<b>Owner</b>	<b>Owner</b>	<p>Owner shall schedule trash pick-up on a weekly basis of each year for the disposal of trash dumpster(s). Owner shall be responsible for enforcing prohibitions on trash/debris (proper disposal) of trash</p>

Description of BMP and Method of Implementation	BMP Responsibility	Maintenance Responsibility	Funding Source For O & M	Maintenance Schedule
<p>standing trash receptacles weekly of each year (office entries). Pedestrian walks shall be inspected and maintained for trash/debris on a weekly basis of each year and properly disposed of.</p> <p>Start-up date: at time of installation</p>				<p>dumpster(s), and free standing trash receptacles. Additionally, ensure maintenance of common area litter control.</p> <p>Pedestrian walks shall be maintained of trash/debris weekly of each year.</p> <p>Furthermore, parking lots shall be maintained of trash/debris on a weekly basis of each year and properly disposed of.</p>
<p><b>Spill Contingency Plan:</b> The owner (building operator), shall prepare a "Spill Contingency Plan" for use by specified types of building or suite occupancies (Specified Use of Buildings Awaiting Lease) and which mandates stockpiling of cleanup materials, notification of responsible agencies, disposal of cleanup materials, documentation, etc. Business Emergency/Contingency Plan Guidelines and Forms shall be provided in accordance with Seciton 6.95 of the California Health and Safety Code. The owner shall educate said tenant/occupants on the Spill Contingency Plan upon move-in and annually thereafter. The owner shall be responsible to enforce the Business Emergency/Contingency Plan Guidelines to subject property through the life of the project.</p>	<p><b>Owner</b></p>	<p><b>Owner</b></p>	<p><b>Owner</b></p>	<p>Owner shall prepare a spill cleanup plan that includes: procedures for different types of spills, schedule for initial &amp; annual training of employees, cleanup kits in well-marked accessible areas, and designation of key employee who monitors cleanup, posting the plan in the work area. Spill Contingency Plan (Business Emergency/Contingency Plan) shall be enforced and utilized by said tenant/occupants and their employees. The Spill Contingency Plan runs with the property "indefinitely".</p>

Description of BMP and Method of Implementation	BMP Responsibility	Maintenance Responsibility	Funding Source For O & M	Maintenance Schedule
<p><b>Employee Training:</b> The owner will be required to educate their contractor’s and the contractor’s employees, and shall provide them with Best Management Practices (BMPs) based on their tasks. (i.e. landscaping/irrigation personnel, street sweeping of parking lot, etc.).</p> <p>Start-up date: Upon indenture</p>	<b>Owner</b>	<b>Owner</b>	<b>Owner</b>	<p>Owner shall be responsible to provide educational materials to contractor’s; (landscape maintenance, catch basin cleaning, landscape and irrigation maintenance, etc.). The owner shall provide a signed form from the contractor that he or she has been given educational materials based on their task and agree to abide by conditions set forth. Educational Materials shall be provided upon indenture and annually thereafter.</p>
<p><b>Catch Basin Inspection:</b> The catch basin with fossil filter insert located south of site (traffic grate inlet) within the parking lot shall be maintained by the owner. The owner shall maintain visual observation of catch basin(s) as stated on the Operations and Maintenance/Stated Maintenance Form (See attachment S). Removal of trash/debris shall be removed by owner/developer and properly disposed of within one (1) day. Furthermore, the owner shall develop a maintenance/service contract with Drainage Protection Systems (DPS) a dba Kristar Enterprises, Inc. for structural maintenance. The contract maintenance shall include, but not limited to; sediment removal by vactor truck, replacement of Fossil Filter Inserts, and for the annual renewal of medium. Structural integrity of broken or otherwise damaged inserts shall be repaired/replaced by Drainage Protection Systems (DPS) at (800) 579-</p>	<b>Owner</b>	<b>Owner</b>	<b>Owner</b>	<p>Catch basin preventative maintenance and routine inspections shall be performed by the owner in accordance with the provisions of this Water Quality Management Plan. The owner shall inspect for debris/trash this shall be a visual observation before and once during each target storm event, weekly during the extended wet periods and monthly during the dry season. The debris/trash shall be removed and properly disposed of within 1 day. The oil and grease removal shall be a visual observation the maintenance indicator for removal are as follows: Absorbent granules are dark gray, or darker or unit is clogged with sediment. The visual observation shall be conducted at the end of each target storm event, weekly during extended</p>

Description of BMP and Method of Implementation	BMP Responsibility	Maintenance Responsibility	Funding Source For O & M	Maintenance Schedule
<p>8819 for the life of the project.</p> <p>Note: Inspections and Cleaning shall apply to all on-site catch basins with and without filter inserts</p> <p>Start-up date: at time of installation</p>				<p>wet periods and monthly during the dry season. Inspection for structural integrity shall be a visual observation of broken or otherwise damaged insert on a monthly basis. Replace media before November 1 of each year. As a guide to the operation and maintenance on how to collect and dispose of sediments: Sediments must be collected by use of a vacor truck which vacuums the sediments out of the drop inlets and other drainage structures. The sediments are then transported daily to designated sites. Registered transporters are used to ship any hazardous sediments from the sites to authorized hazardous waste disposal facilities under standard California Uniform Hazardous Waste Manifests.</p>
<p><b><u>Street Sweeping Private Drive Aisle &amp; Parking Lot:</u></b> Sweeping provides two primary benefits. The more obvious benefit is the collection and removal of paper, leaves, and other visible debris that collect in the gutters. In addition to being unsightly, this debris can block the catch basins and other storm water facilities, causing localized flooding during heavy rains.</p> <p>An equally important, but less visible benefit is the removal of metal particles, and other hazardous waste products left by vehicles. Although they</p>	<p><b>Owner</b></p>	<p><b>Owner</b></p>	<p><b>Owner</b></p>	<p>Owner shall contract with a Street Sweeping Company for private drive aisle and parking lot maintenance. The owner shall be responsible to provide educational materials upon indenture and annually thereafter. The maintenance service contract shall include street sweeping parking lot and drive Isle and inspected for trash/debris/grease and oil on a bi-weekly basis of each year.</p>

Description of BMP and Method of Implementation	BMP Responsibility	Maintenance Responsibility	Funding Source For O & M	Maintenance Schedule
<p>are virtually invisible, these particles can be extremely harmful to the fish and other wildlife.</p> <p>Street sweeping is an effective method of removing both the large and microscopic pollutants that collect on parking lots.</p>				
<p><b><u>Storm Drain System Stenciling and Signage:</u></b> Phrase “No Dumping-Drains to River” to be stenciled on catch basin(s) to alert the public to the destination of pollutants discharged into stormwater. City approved stencil/signage. The owner may contact das Manufacturing, Inc. to purchase the catch basin stenciling/signage. Call “das Curb Maker” at (800) 549-6024.</p> <p>Start up date: Time of installation</p>	<b>Owner</b>	<b>Owner</b>	<b>Owner</b>	<p>Owner shall be responsible to maintain storm drain stenciling &amp; signage: Annually, and/or replace as needed</p>

Description of BMP and Method of Implementation	BMP Responsibility	Maintenance Responsibility	Funding Source For O & M	Maintenance Schedule
<p><b>Efficient Irrigation:</b> The irrigation system shall consist of both drip / bubbler, and highly efficient pressure regulating spray / rotor heads with check valves to prevent overspray and runoff. Sprinkler heads are spaced 24" away from non-permeable paving to prevent runoff. The irrigation system is separated into hydrozones considering plant species factor (according to WULCOL III), plant density, and microclimate. The irrigation system is managed by an ET Based Controller (ET Water Controller) with flow sensor, master valve, and rain shut-off sensor. Project site shall <u>utilize</u> drought tolerant plants, shrubs and trees. Owner shall contract with landscape contractor to maintain landscaped areas of debris, grass clippings, and litter. Owner shall include in contract with landscape contractor to inspect irrigation lines and spray heads for overall efficiency and performance.</p> <p>Start up date: Time of installation</p>	<p><b>Owner</b></p>	<p><b>Owner</b></p>	<p><b>Owner</b></p>	<p>Owner shall be responsible to provide educational material to landscape maintenance contractor for proper functioning of landscape irrigation and water conservation upon indenture and annually thereafter.</p> <p>Maintain: Weekly</p>

# Appendix 10: Educational Materials

*BMP Fact Sheets, Maintenance Guidelines and Other End-User BMP Information*



## Riverside County Stormwater Program Members

City of Banning  
(951) 922-3105

City of Beaumont  
(951) 769-8520

City of Calimesa  
(909) 795-9801

City of Canyon Lake  
(951) 244-2955

City of Cathedral City  
(760) 770-0340

City of Coachella  
(760) 398-3502

City of Corona  
(951) 736-2447

City of Desert Hot Springs  
(760) 329-6411

City of Eastvale  
(951) 361-0900

City of Hemet  
(951) 765-2300

City of Indian Wells  
(760) 346-2489

City of Indio  
(760) 391-4000

City of Jurupa Valley  
(951) 332-6464

City of Lake Elsinore  
(951) 674-3124

City of La Quinta  
(760) 777-7000

City of Menifee  
(951) 672-6777

City of Moreno Valley  
(951) 413-3000

City of Murrieta  
(951) 304-2489

City of Norco  
(951) 270-5607

City of Palm Desert  
(760) 346-0611

City of Palm Springs  
(760) 323-8299

City of Perris  
(951) 943-6100

City of Rancho Mirage  
(760) 324-4511

City of Riverside  
(951) 826-5311

City of San Jacinto  
(951) 487-7330

City of Temecula  
(951) 694-6444

City of Wildomar  
(951) 677-7751

Coachella Valley Water District  
(760) 398-2651

County of Riverside  
(951) 955-1000

Riverside County Flood Control District  
(951) 955-1200

# Stormwater Pollution

*What you should know for...*

## Industrial & Commercial Facilities

Best Management Practices (BMPs) for:

- Industrial Facilities
- Commercial Facilities



# YOU can prevent Stormwater Pollution following these practices...

## Industrial and Commercial Facilities

The Riverside County Stormwater Program has identified a number of Best Management Practices (BMPs) for Industrial and Commercial Facilities. These BMPs control and reduce stormwater pollutants from reaching our storm drain system and ultimately our local water bodies. City and County ordinances require businesses to use these BMPs to protect our water quality. Local cities and the County are required to verify implementation of these BMPs by performing regular facility inspections.

### Prohibited Discharges

Discontinue all non-stormwater discharges to the storm drain system. It is *prohibited* to discharge any chemicals, paints, debris, wastes or wastewater into the gutter, street or storm drain.

### Outdoor Storage BMPs

- Install covers and secondary containment areas for all hazardous materials and wastes stored outdoors in accordance with County and/or City standards.
- Keep all temporary waste containers covered, at all times when not in use.
- Sweep outdoor areas instead of using a hose or pressure washer.
- Move all process operations including vehicle/equipment maintenance inside of the building or under a covered and contained area.
- Wash equipment and vehicles in a contained and covered wash bay which is closed-loop or connected to a clarifier sized to local standards and discharged to a sanitary sewer or take them to a commercial car wash.



### Spills and Clean Up BMPs

- Keep the work site clean and orderly. Remove debris in a timely fashion. Sweep up the area.
- Clean up spills immediately when they occur, using dry clean up methods such as absorbent materials or sweep followed by proper disposal of materials.

- Always have a spill kit available near chemical loading dock doors and vehicle maintenance and fueling areas.
- Follow your Business Emergency Plan, as filed with the local Fire Department.
- Report all prohibited discharges and non-implementation of BMPs to your local Stormwater Coordinator as listed on the back of this pamphlet.
- Report hazardous materials spills to 951-358-5055 or call after hours to 951-782-2973 or, if an emergency, call the Fire Department's Haz Mat Team at 911.



## Plastic Manufacturing Facilities BMPs

AB 258 requires plastic product manufacturers to use BMPs, such as safe storage and clean-up procedures to prevent plastic pellets (nurdles) from entering the waterway. The plastic pellets are released into the environment during transporting, packaging and processing and migrate to waterways through the storm drain system. AB 258 will help protect fish and wildlife from the hazards of plastic pollution.

### Training BMPs

As prescribed by your City and County Stormwater Ordinance(s), train employees in spill procedures and prohibit non-stormwater discharges to the storm drain system. Applicable BMP examples can be found at [www.cabmphandbooks.com](http://www.cabmphandbooks.com).

### Permitting

Stormwater discharges associated with specific categories for industrial facilities are regulated by the State Water Resources Control Board through an Industrial Stormwater General Permit. A copy of this General Permit and application forms are available at: [www.waterboards.ca.gov](http://www.waterboards.ca.gov), select stormwater then the industrial quick link.

To report illegal dumping or for more information on stormwater pollution prevention call: 1-800-506-2555 or e-mail us at: [fcnpdes@rcflood.org](mailto:fcnpdes@rcflood.org).

# IRRIGATION RUNOFF

## STORMWATER FACT SHEET



**Report Irrigation Runoff or Stormwater Pollution:**  
**800.506.2555**

**RIVERSIDE COUNTY**  
WATERSHED PROTECTION

### OVERWATERING

Overwatering causes irrigation runoff that may contain pollutants such as pesticides, herbicides, fertilizers, pet waste, yard waste, and sediments which can be hazardous to residents and harmful to our environment. Runoff can also serve as a transport mechanism for other pollutants already on the ground or in the curb gutter. Irrigation runoff entering the storm drain system is an illicit discharge.

### BEST PRACTICES

Urban runoff begins when yards and landscaped areas are over-irrigated. Irrigation systems require regular maintenance and visual inspection of the system should be performed to prevent over-spray, leaks, and other problems that result in runoff to storm drains, curbs and gutters.

You can **prevent pollution** by conserving water on your property. Water during cooler times of the day (before 10am and after 6pm).

- Adjust sprinklers to stop overspray and runoff.
- Make needed repairs immediately.
- Use drip irrigation, soaker hoses, or micro-spray systems.
- Use an irrigation timer to pre-set watering times.
- Use a control nozzle or similar mechanism when watering by hand.
- Switch to a water-wise landscape - native plants need less fertilizers, herbicides, pesticides and water.

### PROTECT OUR WATERSHED

Many people think that when water flows into a storm drain it is treated, but the storm drain system and the sanitary sewer system are not connected. Everything that enters storm drains flows untreated directly into our creeks, rivers, lakes, beaches and ultimately the ocean. Storm water often contains pollutants, including chemicals, trash, and automobile fluids, all of which pollute our watershed and harm fish and wildlife.

Whether at home or work, you can help reduce pollution and improve water quality by using the above Best Management Practices (BMP's) as part of your daily clean up and maintenance routine.



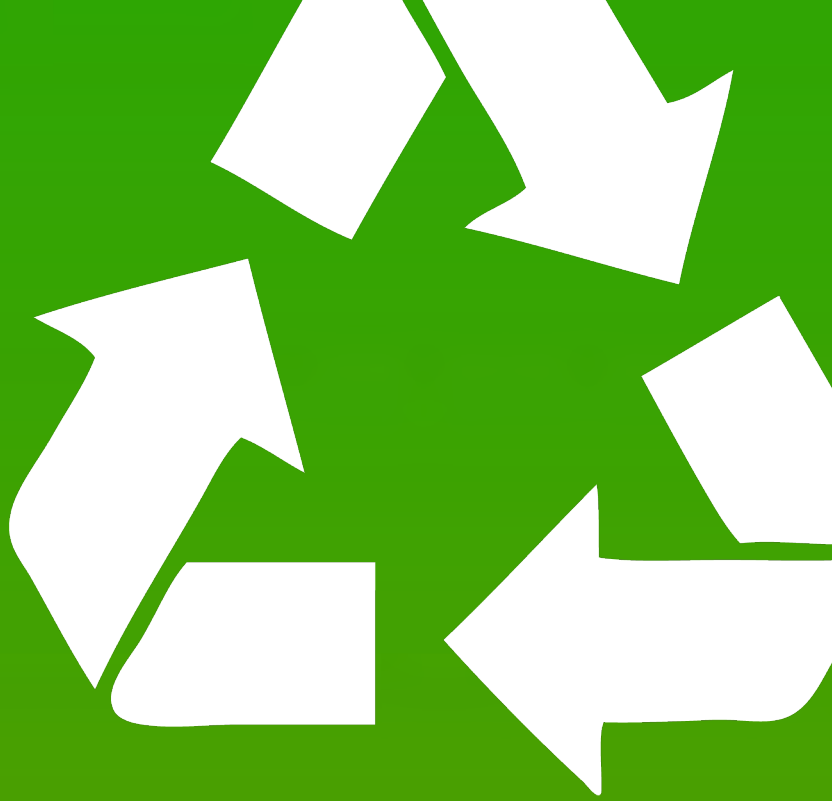

# The Complete Guide to Residential Recycling



## Northwest Riverside County

Banning, Calimesa, Corona, Eastvale, Jurupa Valley,  
Moreno Valley, Norco, Riverside

# Used Oil and Filters



RECYCLE  
USED OIL

**Recycling used motor oil and filters is easy!**  
Simply take them to one of the certified  
collection centers below. **It's free!**

## Banning

### **AutoZone**

3453-A W. Ramsey St.  
(951) 849-7626 

### **Certified Tire & Service Center Goodyear**

1820 W. Ramsey St.  
(951) 849-5028

### **Diamond Hills Auto Group**

4545 W. Ramsey St.  
(951) 849-7861

### **Cruz Industrial Truck Inc.**

313 South Gallaher Way  
(951) 849-7861

## Corona

### **AutoZone**

501 North McKinley St.  
(951) 278-2073 

### **AutoZone**

1280 East Ontario Ave.  
(951) 273-1583 

### **AutoZone**

1014 W. 6th St.  
(951) 371-4730 

### **Corona Nissan**

2575 Wardlow Rd.  
(877) 322-6739

### **Firestone Store**

522 N. Main St.  
(951) 735-4101

### **Goodyear**

**Mountain View Tire**  
1630 E. Ontario Ave.  
(951) 808-0818

### **Hamner Towing & Service Center**

2125 Railroad St.  
(951) 734-9331

### **Heavy Equipment Rentals**

13013 Temescal Cyn. Rd.  
(951) 609-4623

### **Jiffy Lube**

906 W. 6th St.  
(951) 549-9060

### **Jiffy Lube**

1600 E. Ontario Blvd.  
(951) 284-0922

### **O'Reilly Autoparts**

1220 Magnolia Ave.  
Suite 102  
(951) 273-9891 

### **O'Reilly Autoparts**

1142 W. 6th St.  
(951) 735-0936 

### **Pep Boys**

581 N. Main St.  
(951) 279-9230 

### **Quality Toyota**

1700 W. Sixth St.  
(951) 734-6020

### **Ramona Tire**

304 W. Sixth St.  
(951) 734-1222

### **Certified Tire and Service**

624 N. Main St.  
(951) 284-3443

### **Certified Tire and Service**

2189 Sampson Ave., # 111  
(951) 547-2080

### **Team Dykstra Carwash & Lube Center**

2315 California Ave.  
(951) 898-6482

## Eastvale

### **Mountain View Tire**

6080 Hamner Ave., #105  
(909) 484-9497

### **Autozone**

14228 Schleisman Rd.  
(951) 898-4712 

## Jurupa Valley

### **D & B Automotive and Transmission**

4321 Campbell St., #C  
(951) 681-6483

### **Firestone Complete Auto Care**

8360 Limonite Ave.  
(951) 934-7304

### **LKQ Pick A Part**

3760 Pyrite St.  
(800) 749-2720

### **O'Reilly Autoparts**

8702 Limonite Ave.  
(951) 685-0822 



## RECYCLE USED OIL FILTERS

# Used Oil and Filters

You can also find Certified Collection Centers on the Cal Recycle Website:  
[www.calrecycle.ca.gov/recycle](http://www.calrecycle.ca.gov/recycle)

**Scher Goodyear Tire #24**  
6072 Camino Real  
(951) 685-1000

**AutoZone**  
3782 Riverview Dr.  
(951) 275-0301 

### Moreno Valley

**Auto Express  
Moreno Valley**  
24035 Sunnymead Blvd., #G  
(951) 924-6363

**AutoZone**  
27660 Eucalyptus Ave.  
(951) 242-5190 

**AutoZone**  
16210 Perris Blvd.  
(951) 242-2026 

**AutoZone**  
24570 Alessandro Blvd.  
(951) 242-8439 

**AutoZone**  
12601 Perris Blvd.  
(951) 242-4353 

**AutoZone**  
23510 Sunnymead Blvd.  
(951) 924-5460 

**Buds Moreno Valley Tire Pros**  
22510 Alessandro Blvd.  
(951) 776-7211

**Certified Tire & Service Center**  
16190 Perris Blvd.  
(951) 243-5655

**Certified Tire & Service Center**  
23920 Alessandro Blvd., #A  
(951) 656-6466

**Certified Tire & Service Center**  
23135 Hemlock Ave.  
(951) 369-0025

**Firestone**  
24673 Alessandro Blvd.  
(951) 242-6631

**Integrity Tire**  
24901 Sunnymead Blvd.  
(951) 656-6466

**Moss Bros. Chevrolet**  
12625 Auto Mall Dr.  
(951) 658-3145

**Moss Brothers Honda**  
27910 Eucalyptus Ave.  
(951) 486-9366

**Moss Brothers Buick, GMC**  
8146 Auto Drive  
(951) 242-2223

**Moss Brothers  
Chrysler Jeep Dodge**  
27810 Eucalyptus Ave.  
(951) 486-9288

**Moss Brothers Toyota**  
12630 Motor Way  
(951) 247-8000

**Moss Brothers  
Volkswagen**  
27750 Eucalyptus Ave.  
(951) 485-4188

**O'Reilly Autoparts #1304**  
24021 Alessandro Blvd., #C  
(951) 242-0641 

**O'Reilly Autoparts #1704**  
12240 Perris Blvd.  
(951) 247-5509 

**Pep Boys #724**  
23470 Sunnymead Blvd.  
(951) 247-4564 

**Valvoline Instant Oil Change**  
23165 Hemlock Ave.  
(951) 247-1873 

### Norco

**AutoZone #3340**  
1404 Hamner Ave.  
(951) 817-9432

**Browning Dodge  
Chrysler Jeep Ram**  
1983 Hamner Ave.  
(951) 272-3110 

**Jiffy Lube**  
2925 Hamner Ave.  
(951) 284-0210

**Goodyear  
Mountain View Tire**  
2935 Hamner Ave.  
(877) 872-0133

**O'Reilly Autoparts**  
1050 Hamner Ave.  
Suite 1616  
(951) 898-1283 

# Used Oil and Filters



RECYCLE  
USED OIL

## Riverside

### Auto Express

#### Riverside

11850 Magnolia Ave.  
(951) 351-8875

### AutoZone

7315 Indiana Ave.  
(951) 637-6701 

### AutoZone

1947 University Ave.  
(951) 788-4013 

### AutoZone

4195 Van Buren Blvd.  
(951) 359-7760 

### AutoZone

19486 Van Buren Blvd.  
(951) 653-5585 

### AutoZone

10249 Arlington Ave.  
(951) 688-0296 

### AutoZone

6047 Magnolia Ave.  
(951) 784-9201 

### AutoZone

3400 La Sierra Ave.  
(951) 354-0781 

### BMW Of Riverside

3060 Adams St.  
(951) 785-4444

### Bud's Tire and Wheel

8651 Indiana Ave.  
(951) 776-7211

### Bud's Tire and Wheel Orangecrest

15967 Wood Rd.  
(951) 776-7211

### Goodyear Certified Tire & Service Center

8994 Trautwein Rd.  
(951) 653-6800

### Goodyear Certified Tire & Service Center

7341 Indiana Ave.  
(951) 343-8535

### Dutton Motor Company

8201 Auto Dr.  
(951) 687-2020

### Firestone Store

4199 Market St.  
(951) 289-7811

### Firestone Store

10091 Magnolia Ave.  
(951) 977-5863

### George Fritts Auto Repair

91 Commercial Ave.  
(951) 788-9043

### Jiffy Lube

3693 La Sierra Ave.  
(951) 359-8999 

### Malcolm Smith Motorsports

7599 Indiana Ave.  
(951) 687-1300

### Moss Motors Dodge

8151 Auto Center Dr.  
(951) 688-6200

### O'Reilly Autoparts

6160 Arlington Ave.  
(951) 689-0944 

### O'Reilly Autoparts

3790 Jurupa Ave.  
(951) 682-6082 

### O'Reilly Autoparts

1691 University Ave.  
(951) 222-2900 

### O'Reilly Autoparts

9929 Magnolia Ave.  
(951) 359-3041 

### O'Reilly Autoparts

18570 Van Buren Blvd.  
(951) 780-8721 

### Pep Boys #690

10831 Magnolia Ave.  
(951) 354-0100

### Raceway Ford

5900 Sycamore Canyon Blvd.  
(951) 784-1000

### Raceway Nissan

6030 Sycamore Canyon Blvd.  
(951) 571-9300

### Riverside Mitsubishi and Kia

8100 Auto Dr.  
(951) 509-1000



## RECYCLE USED OIL FILTERS

# Used Oil and Filters

**Riverside Nissan**  
8330 Indiana Ave.  
(951) 509-6581

**Singh Chevrolet**  
8200 Auto Center Dr.  
(951) 688-8111

**Spoiled**  
2634 E. Alessandro Blvd.  
(951) 656-2300

**Toyota of Riverside**  
7870 Indiana Ave.  
(951) 687-1622

**Valvoline Instant Oil Change**  
3504 Central Ave.  
(951) 367-0411 

**Valvoline Instant Oil Change**  
7450 Mission Grove  
Pkwy. South  
(951) 780-2500 

**Valvoline Instant Oil Change**  
7437 Arlington Ave.  
(951) 689-7805 

**Valvoline Instant Oil Change**  
3417 Arlington Ave.  
(951) 788-7725 

**Valvoline Instant Oil Change**  
18681 Van Buren Blvd.  
(951) 789-2882 

**Valvoline Instant  
Oil Change**  
3335 Iowa Blvd.  
(951) 367-0147

**Walters Mercedes-Benz**  
3213 Adam's St.  
(888) 656-3915

**Walters Porsche/Audi**  
3210 Adams St.  
(888) 656-3915

**Curbside pickup of used oil** is available in some cities in Riverside County. Contact your waste hauler for more information. Waste hauler contact information is provided on the back page of this guide.



**You may not need to change your oil every 3000 miles!** Save time, money, and the environment by visiting [www.checkyournumber.org](http://www.checkyournumber.org) to find out what your manufacturer recommended oil change interval is.

Check your number is provided by CalRecycle.

Locations marked with a  also accept oil filters.

**Please DO NOT drop off oil when the location is closed.** For more information about used oil collection centers call 800-350-4OIL.

# Household Hazardous Waste

Examples of household waste that are considered hazardous include:

- Batteries (all types)
- Electronic Waste
- Paint
- Used Oil and Antifreeze
- Sharps/ Needles



## Permanent Household Hazardous Waste Collection Centers

### Lake Elsinore Area (Closed January and December)

Lake Elsinore Regional Permanent HHW Collection Facility  
512 N. Langstaff Street, Lake Elsinore, 92530

Open first Saturday of the month\*, 9:00 a.m. to 2:00 p.m.

\*Except holiday weekends and during inclement weather.

### Riverside Area

Agua Mansa Regional Permanent HHW Collection Facility  
1780 Agua Mansa Road, Riverside, 92509

Open non-holiday Saturdays\*, 9:00 a.m. to 2:00 p.m.

\*Except during inclement weather.

## Regional ABOP Collection Centers (Antifreeze, Batteries, Oil and Oil Filters, and Latex Paint ONLY)

### Murrieta Area

County Road Yard  
25315 Jefferson Avenue, Murrieta, 92562

Open non-holiday Saturdays, 9:00 a.m. to 2:00 p.m.

### Beaumont / Banning Area

Lamb Canyon Landfill  
16411 Lamb Canyon Rd, Beaumont, 92223

Open non-holiday Saturdays, 9:00 a.m. to 2:00 p.m.

These sites accept residential waste only. For more information, contact the Riverside County Household Hazardous Waste Department Hotline at **800-304-2226** or **951-486-3200**, or visit:

[www.rivcowm.org/opencms/hhw/index.html](http://www.rivcowm.org/opencms/hhw/index.html)

# Household Hazardous Waste

Below is a list of materials accepted at permanent HHW collection sites.\*

## Chemicals and Cleaners

Adhesives	Flea Powder	Paint - Latex / Oil Based
Air Freshener	Floor / Surface Cleaners	Paint Stripper / Thinner
Aluminum Cleaners	Fungicides	Photo Chemicals
Ammonia	Furniture Polish	Pool / Spa Chemicals
Antifreeze	Gas / Diesel Fuel	Rodent Bait / Poison
Brake Fluid	Glue	Roof Coating
Carburetor Cleaner	Gun Cleaner	Shoe Dye
Caulking	Hair Dye	Spot Remover
Chlorine Bleach	Hobby Chemicals	Transmission Fluid
Chrome Polish	Insecticides / Pesticide	Turpentine
Disinfectant	Kerosene / Lamp Oil	Varnish
Drain Cleaner	Lighter Fluid	Weed Killer / Herbicide
Engine Degreaser	Motor Oil	Wood Preservative
Fertilizer	Mercury Devices	
Fiberglass and Resins	Oven Cleaner	

## Aerosols and Tanks

Aerosol Insecticides  
Aerosol Cans  
BBQ Propane Tanks  
Camp Propane Tanks

## E-Waste and Batteries

Batteries (all types)  
Electronic Devices  
Fluorescent Bulbs / Tubes  
Old TVs and Computers

## Medical Waste

Sharps / Needles

Please **DO NOT** bring the following types of materials (If you have any of these wastes please call (951) 486-3200):

## Unacceptable Materials

Business, Non-Profit, or Out-of-County Waste	Appliances
Explosives / Ammunition	Tires
Radioactive or Remediation Materials	55 or 30 Gallon Drums
Medical / Infectious Waste (Except Sharps)	Compressed Gas Cylinders >40 lbs
Asbestos	Trash

\*Maximum Chemical Load: 5 Gallons or 50lbs per trip. Residential waste only, no business waste accepted.

# Recycling

**What can go into your curbside recycling bins?** Not sure what you can recycle? Check out the list below.

## Paper and Cardboard

- Books and Coloring Books
- Cardboard
- Cardstock and Construction Paper
- Office Paper
- Egg Cartons
- Clean Food Boxes
- Junk Mail and Envelopes
- Magazines and Newspapers
- Notebook Paper
- Paper Bags
- Telephone Books



## Metal

- Aluminum and Steel Cans
- Clean Aluminum Foil
- Scrap Metal



## Glass Jars and Bottles

- Glass Jars
- Beverage Bottles



## Plastic Bottles and Grocery Bags

- Plastic Milk Jugs
- Plastic Beverage Containers
- Plastic Grocery Bags



# Recycling

## Used Tires

Used tires are accepted at various locations in Riverside County. There is generally a fee to dispose of tires. The following locations accept tires:

### Badlands Landfill

*31125 Ironwood Ave., Moreno Valley, 92553*

### Lamb Canyon Landfill

*16411 Lamb Canyon Rd., Beaumont, 92223*



Visit [www.rivcowm.org/opencms/landfill\\_info/landfill\\_fees.html](http://www.rivcowm.org/opencms/landfill_info/landfill_fees.html) for information on current landfill pricing.

### BAS Recycling, Inc.

*14050 Day St., Moreno Valley, 92553*

*(909) 383-7050*

Call facility for pricing.

## Electronic Waste Recyclers

Badlands, Lamb Canyon, and El Sobrante Landfills accept up to 2 CRT devices (e.g. computer monitors or TVs) per day for recycling at **no cost** during operating hours. The following recyclers also accept electronic waste:

**Gold'n West Surplus**, Corona - (951) 371-2020

**Graebel Los Angeles Movers**, Corona - (800) 373-6552

**WM Recycle America**, Jurupa Valley - (951) 681-4297

**Waste Management, Inc.**, Moreno Valley - (951) 242-0421

**Your Neighborhood Recycling**, Moreno Valley - (951) 796-7673

**1-800-GOT-JUNK**, Riverside - (909) 425-9722

## Other Recycling Facilities

For a complete list of recycling facilities visit [www.calrecycle.ca.gov](http://www.calrecycle.ca.gov).

[Earth911.com](http://Earth911.com) also provides valuable information and resources about recycling and recycling facilities

# Recycling Centers

**What should you do with those empty cans and bottles?** Below is a list of centers that accept beverage containers for recycling\*.

## Banning

**Banning Recycling**  
284 S. 8th St.  
(951) 922-9236

**Ramsey Recycling**  
1243 E. Ramsey St.  
(951) 849-5997

## Calimesa

**rePlanet**  
1155 Calimesa Blvd.  
(877) 737-5263

## Corona

**NexCycle**  
535 N. McKinley St.  
(800) 969-2020

**rePlanet**  
260 W. Foothill Pkwy.  
(951) 520-1700

**rePlanet**  
1193 Magnolia Ave.  
(877) 737-5263

**rePlanet**  
1288 Border Ave.  
(877) 737-5263

**Sanchez Recycling Inc.**  
1130 W. 6th St.  
(714) 793-9934

**Six Pac Recycling**  
1430 E. 6th St.  
(951) 734-2910

## Eastvale

**rePlanet**  
7070 Archibald Ave.  
(951) 520-1700

**rePlanet**  
12660 Limonite Ave.  
(951) 520-1700

## Jurupa Valley

**Etiwanda Recycling**  
6102 Etiwanda Ave.  
(951) 263-6173

**Recycle Kingdom**  
4868 Etiwanda Ave.  
(626) 617-1859

**rePlanet**  
11070 Limonite Ave.  
(877) 737-5263

**Salazar's Recycler**  
5666 Etiwanda Ave.  
(951) 966-6408

**EarthWize Recycling**  
9075 Mission Blvd.  
(909) 933-2773

**Jurupa Valley Recycling Collection Center**  
6315 Pedley Rd.  
(951) 681-0382

**Pedley Recycling Center**  
7850 Limonite Ave.  
(951) 823-1383

**Pedley Vet Recycling**  
8980 Limonite Ave.  
(909) 856-9053

**Recycling Services Centers**  
6565 Mission Blvd.  
(951) 685-4430

**Renovate Recycling Center**  
8800 Limonite Ave.  
(714) 453-7028

**rePlanet**  
9155 Jurupa Rd.  
(877) 737-5263

**Rubidoux Recycling Center**  
5675 Mission Blvd.  
(951) 823-1353

## Moreno Valley

**EarthWize Recycling**  
24525 Alessandro Blvd.  
(909) 923-2773

**Menlo Recycling Center**  
22405 Goldencrest Dr.  
Bldg., A.  
(951) 653-5565

**Moreno Valley Recycling**  
22862 Alessandro Blvd.  
(323) 732-9253

**Moreno Valley Recycling 2**  
24135 Sunnymead Blvd.  
(213) 625-8165

**Moreno Valley Recycling 3**  
14940 Perris Blvd.  
(323) 732-9253

# Recycling Centers

## rePlanet

23575 Sunnymead  
Ranch Pkwy.  
(951) 520-1700

## rePlanet

27100 Eucalyptus Ave.  
(951) 520-1700

## rePlanet

25900 Iris Ave.  
(951) 520-1700

## Smittys

25073 Sunnymead Blvd.,  
#D-14  
(951) 453-0806

## Worasing Recycling

15928 Perris Blvd.  
(951) 323-7532

## Zuniga Recycling

21524 Dracea Ave.  
(866) 718-7150

## Norco

## E&M Recycling

1943 River Rd.  
(323) 732-9253

## Norco Feed and Recycling

4409 California Ave.  
(877) 247-6923

## rePlanet

2790 Hamner Ave.  
(877) 737-5263

## Riverside

## AAA Recycle

5490 26th St.  
(951) 781-8046

## ABC

10330 Hole Ave., #B-9  
(909) 742-7129

## Cash 4 Cans

7633 Cypress Ave.  
(951) 352-5995

## El Taray Recycling

12702 Magnolia Ave.,  
#11  
(714) 222-4047

## rePlanet

4250 Van Buren Blvd.  
(951) 520-1700

## rePlanet

6155 Magnolia Ave.  
(951) 520-1700

## rePlanet

5225 Canyon Crest Dr.  
(951) 520-1700

## rePlanet

315 E. Alessandro Blvd.  
(951) 520-1700

## rePlanet

3900 Chicago Ave.  
(951) 520-1700

## rePlanet

2995 Iowa Ave.  
(951) 520-1700

## rePlanet

6160 Arlington Ave.  
(951) 520-1700

## rePlanet

9225 Magnolia Ave.  
(951) 520-1700

## rePlanet

17050 Van Buren Blvd.  
(951) 520-1700

## rePlanet

3420 La Sierra Ave.  
(951) 520-1700

## rePlanet

4680 La Sierra Ave.  
(951) 520-1700

## Riverside Scrap Iron and Metal Corp.

2993 6th St.  
(951) 686-2129

## Robert A. Nelson Transfer Station

1830 Agua Mansa Rd.  
(951) 786-0639

## rePlanet

4250 Van Buren Blvd.  
(951) 520-1700

\*Some recycling centers may accept other recyclable materials. It is advisable to call the center and confirm this, as well as operating hours, before visiting.

For more information about local recycling centers visit the  
**CalRecycle** website: [www.calrecycle.ca.gov](http://www.calrecycle.ca.gov).

# Types of Plastic

**Confused about the types of plastic and if they can be recycled?** Many plastic containers display an identification code that indicates what they are made from. Below are the 7 codes.



**#1: Polyethylene Terephthalate (PETE or PET)**  
Used to create 2-liter soda bottles, water bottles, cooking oil bottles, peanut butter jars.  
*The most commonly accepted plastic for recycling.*



**#2: High Density Polyethylene**  
Used to create detergent bottles, milk and water jugs, grocery bags, yogurt cups.  
*Commonly accepted for recycling. Bags can be recycled at some large grocery stores.*



**#3: Polyvinyl Chloride**  
Used to create plastic pipes, outdoor furniture, shrink-wrap, liquid detergent containers, flooring, showercurtains.  
*Not currently accepted for recycling.*



**#4: Low Density Polyethylene**  
Used to create food storage containers, cellophane wrap, dry cleaning bags, produce bags, trash can liners.  
*Not commonly recycled, some large grocery stores accept LDPE bags.*



**#5: Polypropylene**  
Used to create ketchup bottles, aerosol caps, drinking straws, yogurt containers.  
*Not commonly accepted for recycling.*



**#6: Polystyrene**  
Also known as "Styrofoam." Used to make coffee cups, take-out food packaging, egg cartons, and packaging "peanuts."  
*Sometimes accepted for recycling and made into the same products.*



**#7: Other**  
All other plastic resins or a mixture of resins used to make reusable water bottles, Tupperware, biodegradable and compostable plastics  
*Not commonly accepted for recycling.*

# Composting Basics

**Got food scraps and yardwaste?** Below is a quick guide to Backyard Composting.

## 1. Select a good spot for composting

- Sun or shade
- Convenient to kitchen or garden, and close to a source of water
- Keep away from structures and wood, as moisture can hasten decay
- Place only on bare ground, as organisms from soil are needed

## 2. Know the Ingredients

**Nitrogen** - Green materials - grass clippings, fresh leaves and twigs, vegetable and fruit trimmings, coffee grounds and filters, and non-meat eating animal manures.

**Carbon** - Brown materials that have released their nitrogen - dry and brittle leaves and grasses, straw, wood chips, corn stalks, shredded newspaper, paper towels, napkins, and cardboard.

**Water** - The correct moisture level should be about the same as a damp wrung out sponge. A few drops should fall when squeezed in your hand.

**Air** - Oxygen is very important to the bacteria, fungi, and microorganisms that are working in the pile to breakdown the organic material.

**Do Not Add** - Meat, dairy products, fats, oils, waste from meat eating animals (dogs and cats), thorny plant material, or diseased plant material.

## 2. Know the Methods

**Aerobic** - Pile equal parts green and brown material on ground or in a bin in a 3'x3'x3' heap, water well, and cover with a tarp, carpet or opaque plastic sheet. The pile will heat up (120 to 160 degrees), and needs to be turned after a few days, once it has cooled. Turn the pile weekly and continue composting until the pile has a dark rich look like chocolate cake and the things you put in don't look like their original form. After the compost is done, water well, cover, and let it rest for one to two weeks to make sure it is completely done and the nitrogen has a chance to stabilize. If the compost is used too soon it could rob nutrients from the surrounding plants. Remove large chunks and add them to the next compost pile.

**Anerobic** - Similar to the Aerobic method, but there is no need to actively turn the material. It may take longer (1-2 years), but is still beneficial to your garden. Just pile the stuff, water, cover, and wait.

For more detailed information on composting, free workshops, or other methods, such as **Vermicomposting**, visit [www.rivcowm.org](http://www.rivcowm.org) and search for composting

# Source Reduction

**The best way to reduce waste is to prevent it!**

## Buy Responsibly

**Reduce packaging waste** - Look for products that reduce packaging, or purchase in bulk to reduce the amount of packaging needed.

**Look for products containing recycled material** - Recycled paper products, motor oil, and even pens and pencils are just a few examples of products that reduce waste.

**Consider reusable products** - Buy reusable water bottles and sturdy utensils and plates that can be washed and used again.

**Get it “For Here,” or bring your own** - Many coffee shops will provide drinks to their customers in ceramic mugs rather than paper cups if requested. Just ask! Reusable tumblers are also a great alternative to paper cups, and many establishments will even give a small discount to those who bring their own!

**Borrow, rent, or share** - Why buy something if you are only going to use it once? Items such as tools, party decorations, and even newspapers and magazines can be shared with your friends, family, and/or community.

**Purchase rebuilt, remanufactured, or refurbished** - Many electronics such as cell phones, computers, and media players can be purchased “refurbished” at a sometimes substantial price reduction. This conserves the resources needed to manufacture a new product.

## Choose Non-Toxic

Choose products that contain only non-toxic materials, or try one of these **homemade alternatives**:

- Instead of glass cleaner, dilute 1 cup of vinegar in 1 quart of water.
- To open clogged drains, flush with a mixture of boiling water, and equal parts baking soda and vinegar.

For more information on non-toxic alternatives, visit the California Coastal Commission website:

[http:// www.coastal.ca.gov/ccbn/lesstoxic.html](http://www.coastal.ca.gov/ccbn/lesstoxic.html)

# Source Reduction

**Plastic bags and junk mail contribute to a significant amount of un-needed waste.** You can lessen their impact by Reducing, Reusing, and Recycling.



## Plastic Bags

**Reduce: BYOB (Bring Your Own Bag)** - Use reusable canvas or cloth bags rather than plastic bags, and keep them in your car. Not all items need a bag, just say “no, thank you.”

**Reuse** - Plastic grocery bags can serve multiple purposes, such as trash can liners or for pet waste.

**Recycle** - If you find that you must use a plastic bag, recycle it when you are finished. Most large supermarkets and pharmacies offer free recycling of plastic bags.

## Junk Mail Reduction

You can reduce the amount of unwanted junk mail in your mailbox by simply mailing a postcard to the following addresses, requesting your name be removed from their mailing list. Be sure to include your full name, your address(es), your signature, and the date.

Mail Preference Service  
Attn.: Dept. 10088342  
PO Box 282  
Carmel, NY 10512

ADVO  
Consumer Assistance  
PO Box 249  
Windsor, CT 06095

Harte-Hanks Circulatio  
C/O Pennysaver  
2830 Orbiter St.  
Brea, CA 92821

Valpak Direct Marketing Systems, Inc.  
8605 Largo Lakes Dr.  
Largo, FL 33773

Credit Card Junk Mail  
Call (888)5-OPT OUT (888-567-8688)

## City / County Resources

**City of Banning - Recycling and Waste Hauling Information | (951) 922-3105**  
[http:// www.ci.banning.ca.us/index.aspx?NID=380](http://www.ci.banning.ca.us/index.aspx?NID=380)

**City of Calimesa - Public Works / Engineering Department | (909) 795-9801**  
[http:// www.cityofcalimesa.net/publicworks.htm](http://www.cityofcalimesa.net/publicworks.htm)

**City of Corona - Trash and Recycling | (951) 736-2400**  
[http:// www.discovercorona.com/city-departments/public-works/refuse-and-recycling.aspx](http://www.discovercorona.com/city-departments/public-works/refuse-and-recycling.aspx)

**City of Eastvale - Recycling / Solid Waste / Street Sweeping | (951) 361-0900**  
[http:// www.eastvalecity.org/index.aspx?page=140](http://www.eastvalecity.org/index.aspx?page=140)

**City of Jurupa Valley - Local Resources | (951) 358-7387**  
[http:// www.jurupavalley.org/resources.php](http://www.jurupavalley.org/resources.php)

**City of Moreno Valley - Waste Disposal and Recycling | (951) 413-3100**  
[http:// www.moreno-valley.ca.us/resident\\_services/waste/index-waste.shtml](http://www.moreno-valley.ca.us/resident_services/waste/index-waste.shtml)

**City of Norco - Trash / Recycling | (951) 270-5656**  
[http:// www.norco.ca.us/about/welcome\\_residents/trash\\_recycling.asp](http://www.norco.ca.us/about/welcome_residents/trash_recycling.asp)

**City of Riverside - Trash & Recycling | (951) 826-5311**  
[http:// www.riversideca.gov/trash](http://www.riversideca.gov/trash)

**County of Riverside - Riverside County Waste Management Department**  
[http:// www.rivcowm.org](http://www.rivcowm.org) | (951) 486-3200

**Western Riverside Council of Governments**  
[http:// www.wrcog.cog.ca.us](http://www.wrcog.cog.ca.us) | (800) 350-4645

## Waste Haulers

**Waste Management, Inc. - (951) 280-5400 - [www.wm.com](http://www.wm.com)**  
Serves: All Cities

**Burrtec - (951) 786-9660 - [www.burrtec.com](http://www.burrtec.com)**  
Serves: Eastvale, Jurupa Valley, and Riverside

**Athens - (888) 336-6100 - [www.athensservices.com](http://www.athensservices.com)**  
Serves: Riverside

**CR&R Disposal - (951) 943-1991 - [www.crrwasteservices.com](http://www.crrwasteservices.com)**  
Serves: Riverside

**The Complete Guide to Residential Recycling is sponsored by:**



Printed on recycled paper.



# The Complete Guide to Residential Recycling



**Southwest Riverside County**  
Canyon Lake, Hemet, Lake Elsinore, Menifee,  
Murrieta, Perris, San Jacinto, Temecula, Wildomar

# Used Oil and Filters

Recycling used motor oil and filters is easy!  
Simply take them to one of the certified  
collection centers below. **It's free!**



# Used Oil and Filters

You can also find Certified Collection  
Centers on the Cal Recycle Website:  
[www.calrecycle.ca.gov/recycle](http://www.calrecycle.ca.gov/recycle)

## Hemet

**AutoZone #2820**  
1550 W. Florida Ave.  
(951) 929-0807 

**AutoZone #5556**  
3100 E. Florida Ave.  
(951) 652-1308 

**EZ Lube #112**  
532 W. Florida Ave.  
(951) 766-1996

**Firestone Store #2233**  
350 W. Florida St.  
(951) 929-2424

**Inland Chevrolet**  
350 Carriage Circle  
(951) 658-4401

**Integrity Tire**  
3223 W. Florida Ave.  
(951) 658-3145

**Jiffy Lube #3187**  
330 N Sanderson Ave.  
(951) 487-2001

**Masterlube #101**  
3615 W. Florida St.  
(951) 766-7055

**O'Reilly Autoparts #1332**  
849 W. Florida Ave.  
(951) 929-2210

**Pep Boys #866**  
2050 W. Florida Ave.  
(951) 766-1477

**Ramona Tire**  
2350 W. Menlo Ave.  
(951) 925-6659

**Synfast Oil Change**  
3615 W. Florida Ave.  
(951) 766-7055

**Valvoline Instant  
Oil Change**  
532 W. Florida Ave.  
(951) 766-1996 

## Idyllwild

**Idyllwild Garage**  
25015 Hwy. 243  
(951) 659-2613

## Lake Elsinore

**AutoZone #5558**  
30870 Riverside Dr.  
(951) 674-7806

**AutoZone #5559**  
32231 Mission Trail  
(951) 245-1012 

**Express Tire**  
300 Diamond Dr.  
(951) 674-0794

**EZ Lube #96**  
29285 Central Ave.  
(951) 253-5200

**Firestone Store #2238**  
31748 Mission Trail  
(951) 674-0633

**Jiffy Lube #2681**  
311 Summerhill Dr.  
(951) 471-8445

**O'Reilly Autoparts #1429**  
31660 Grape St.  
(951) 245-8389

**Valvoline Instant Oil Change**  
29285 Central Ave.  
(951) 253-5200 

## Menifee

**AutoZone #5561**  
30123 Antelope Rd.  
(951) 301-7240 

**One Stop Lube & Oil  
Center**  
26825 Newport Rd.  
(951) 301-7479

## Murrieta

**AutoZone #5566**  
40950 California Oaks Rd.  
(951) 677-6206

**Express Tire**  
40615 California Oaks Rd.  
(951) 696-5200

**EZ Lube #115**  
40430 California Oaks Rd.  
(951) 696-2882

**Mountain View Tire and  
Service**  
27584 Clinton Keith Rd.  
(888) 860-0535 

**Murrieta Volkswagen**  
41300 Date St.  
(951) 634-5434

**O'Reilly Autoparts #1430**  
40951 California Oaks Rd.  
(951) 696-2991

**Valvoline Instant Oil Change**  
40430 California Oaks Rd.  
(951) 696-2882 

## Perris

**AutoZone #5570**  
401 E. 4th St.  
(951) 657-0696

**AutoZone #5571**  
1675 Perris Blvd.  
(951) 943-5998

**Jiffy Lube #3294**  
118 E. Ramona Expressway  
(951) 943-2200

**Jiffy Lube #3361**  
3150 Case Rd., Bldg. J.  
(951) 284-0922

**O'Reilly Autoparts #1046**  
119 W. Nuevo Rd.  
(951) 657-1488

## San Jacinto

**AutoZone #5581**  
1540 San Jacinto Ave.  
(951) 654-2216 

**Jiffy Lube #3186**  
635 S. State St.  
(951) 487-2001

**Ramona Auto Services, Inc.**  
2447 S. San Jacinto Ave.  
(951) 925-5117

## Temecula

**AutoZone #5582**  
31837 US Hwy. 79  
(951) 302-8334 

**AutoZone #5936**  
40345 Winchester Rd.  
(951) 296-3973 

**DCH Acura of Temecula**  
26705 Ynez Rd.  
(951) 491-2451 

# Used Oil and Filters



# Used Oil and Filters

## Temecula

**DCH Chrysler Jeep Dodge of Temecula**  
26845 Ynez Rd.  
(951) 491-2151

**DCH Honda of Temecula**  
26755 Ynez Rd.  
(951) 491-2351

**Express Tire**  
40915 Winchester Rd.  
(951) 296-6699

**Express Tire**  
44092 Margarita Rd.  
(951) 302-5033

**Express Tire**  
29095 Front St.  
(951) 695-0555

**EZ Lube #85**  
30625 Highway 79 South  
(951) 553-7399

**Jiffy Lube #1878**  
30690 Rancho California Rd.  
(951) 694-5460

**John Hine Temecula Mazda**  
42050 DLR Dr.  
(951) 553-2000

**O'Reilly Autoparts #0483**  
41125 Winchester Rd., #C1  
(951) 296-5530

**O'Reilly Autoparts #4291**  
33417 Temecula Pkwy.  
(951) 302-1351

**Paradise Chevrolet Cadillac**  
27360 Ynez Rd.  
(951) 506-0058

**Pep Boys #800**  
40605 Winchester Rd.  
(951) 695-2322

**Precision Tune Auto Care**  
26673 Ynez Rd., #A  
(951) 699-6969

**Promethean Biofuels Cooperative**  
27635 Diaz Rd.  
(626) 232-7608

**Quality Nissan**  
41895 Motor Car Pkwy.  
(951) 676-6601

**Ramona Auto Services, Inc.**  
40385 Winchester Rd.  
(951) 719-1600

**Ramona Auto Services, Inc.**  
31955 Via Rio Rd.  
(951) 303-3584

**Ramona Tire**  
40385 Winchester Rd.  
(951) 719-1600

**Rancho Car Wash and Quick Lube**  
27378 Jefferson Ave.  
(951) 296-5644

**Temecula Hyundai**  
27430 Ynez Rd.  
(951) 699-6807

**Temecula Quick Lube**  
29764 Rancho California Rd.  
(951) 587-6624

**Valvoline Instant Oil Change**  
30625 Highway 79 South  
(951) 553-7399

## Wildomar

**Grease Monkey**  
32120 Clinton Keith Rd.  
(951) 609-3000

**Jiffy Lube #3412**  
32374 Clinton Keith Rd.  
(951) 678-5300

## Winchester

**Mountain View Tire/Goodyear**  
30664 Benton Rd.  
(877) 872-1021

**Curbside pickup of used oil** is available in some cities in Riverside County. Contact your waste hauler for more information. Waste hauler contact information is provided on the back page of this guide.

**You may not need to change your oil every 3000 miles!** Save time, money, and the environment by visiting [www.checkyournumber.org](http://www.checkyournumber.org) to find out what your manufacturer recommended oil change interval is.

Locations marked with a  also accept oil filters.

**Please DO NOT drop off oil when the location is closed.** For more information about used oil collection centers call 800-350-4OIL.

# Household Hazardous Waste

# Household Hazardous Waste

Examples of household waste that are considered hazardous include:

- Batteries (all types)
- Electronic Waste
- Paint
- Used Oil and Antifreeze
- Sharps/ Needles



## Permanent Household Hazardous Waste Collection Centers

### Lake Elsinore Area (Closed January and December)

Lake Elsinore Regional Permanent HHW Collection Facility  
512 N. Langstaff Street, Lake Elsinore, 92530

Open first Saturday of the month\*, 9:00 a.m. to 2:00 p.m.

\*Except holiday weekends and during inclement weather.

### Riverside Area

Agua Mansa Regional Permanent HHW Collection Facility  
1780 Agua Mansa Road, Riverside, 92509

Open non-holiday Saturdays\*, 9:00 a.m. to 2:00 p.m.

\*Except during inclement weather.

## Regional ABOP Collection Centers (Antifreeze, Batteries, Oil and Oil Filters, and Latex Paint ONLY)

### Murrieta Area

County Road Yard

25315 Jefferson Avenue, Murrieta, 92562

Open Non-Holiday Saturdays, 9:00 a.m. to 2:00 p.m.

These sites accept residential waste only. For more information, contact the Riverside County Household Hazardous Waste Department Hotline at **800-304-2226** or **951-486-3200**, or visit, [www.rivcowm.org/opencms/hhw/index.html](http://www.rivcowm.org/opencms/hhw/index.html)

Below is a list of materials accepted at permanent HHW collection sites.\*

### Chemicals and Cleaners

Adhesives	Flea Powder	Paint - Latex / Oil Based
Air Freshener	Floor / Surface Cleaners	Paint Stripper / Thinner
Aluminum Cleaners	Fungicides	Photo Chemicals
Ammonia	Furniture Polish	Pool / Spa Chemicals
Antifreeze	Gas / Diesel Fuel	Rodent Bait / Poison
Brake Fluid	Glue	Roof Coating
Carburetor Cleaner	Gun Cleaner	Shoe Dye
Caulking	Hair Dye	Spot Remover
Chlorine Bleach	Hobby Chemicals	Transmission Fluid
Chrome Polish	Insecticides / Pesticide	Turpentine
Disinfectant	Kerosene / Lamp Oil	Varnish
Drain Cleaner	Lighter Fluid	Weed Killer / Herbicide
Engine Degreaser	Motor Oil	Wood Preservative
Fertilizer	Mercury Devices	
Fiberglass and Resins	Oven Cleaner	

### Aerosols and Tanks

Aerosol Insecticides  
Aerosol Cans  
BBQ Propane Tanks  
Camp Propane Tanks

### E-Waste and Batteries

Batteries (all types)  
Electronic Devices  
Fluorescent Bulbs / Tubes  
Old TVs and Computers

### Medical Waste

Sharps / Needles

Please **DO NOT** bring the following types of materials (If you have any of these wastes please call (951) 486-3200):

### Unacceptable Materials

Business, Non-Profit, or Out-of-County Waste	Appliances
Explosives / Ammunition	Tires
Radioactive or Remediation Materials	55 or 30 Gallon Drums
Medical / Infectious Waste (Except Sharps)	Compressed Gas Cylinders >40 lbs
Asbestos	Trash

\*Maximum Chemical Load: 5 Gallons or 50lbs per trip. Residential waste only, no business waste accepted.

# Recycling

# Recycling

**What can go into your curbside recycling bins?** Not sure what you can recycle? Check out the list below.

## Paper and Cardboard

- Books and Coloring Books
- Cardboard
- Cardstock and Construction Paper
- Office Paper
- Egg Cartons
- Clean Food Boxes
- Junk Mail and Envelopes
- Magazines and Newspapers
- Notebook Paper
- Paper Bags
- Telephone Books



## Metal

- Aluminum and Steel Cans
- Clean Aluminum Foil
- Scrap Metal



## Glass Jars and Bottles

- Glass Jars
- Beverage Bottles



## Plastic Bottles and Grocery Bags

- Plastic Milk Jugs
- Plastic Beverage Containers
- Plastic Grocery Bags



## Used Tires

Used tires are accepted at various locations in Riverside County. There is generally a fee to dispose of tires. The following locations accept tires:

### Badlands Landfill

31125 Ironwood Ave., Moreno Valley, 92553

### Lamb Canyon Landfill

16411 Lamb Canyon Rd., Beaumont, 92223



Visit [www.rivcowm.org/opencms/landfill\\_info/landfill\\_fees.html](http://www.rivcowm.org/opencms/landfill_info/landfill_fees.html) for information on current landfill pricing.

### BAS Recycling, Inc.

14050 Day St., Moreno Valley, 92553

(909) 383-7050

Call facility for pricing.

## Electronic Waste Recyclers

Badlands, Lamb Canyon, and El Sobrante Landfills accept up to 2 CRT devices (e.g. computer monitors or TVs) per day for recycling at **no cost** during operating hours. The following recyclers also accept electronic waste:

**The Green Guys Recycling**, Hemet - (951) 757-9156

**Starsurplus.com**, Murrieta - (951) 677-5696

**XIT Communications**, Murrieta - (951) 691-5138

**CR&R**, Perris - (800) 755-8112

**Tire Stop & Recycling**, Sun City - (951) 928-9600

**GKAT, INC. dba Temecula Recycling**, Temecula - (951) 693-1500

**Heavy Metal Scrap & Recycling, Inc.**, Temecula - (951) 693-4677

## Other Recycling Facilities

For a complete list of recycling facilities visit [www.calrecycle.ca.gov](http://www.calrecycle.ca.gov) and click on the "Recycle Tab."

[Earth911.com](http://Earth911.com) also provides valuable information and resources about recycling and recycling facilities

# Recycling Centers

**What should you do with those empty cans and bottles?** Below is a list of centers that accept beverage containers for recycling\*.

## Hemet

**EarthWize Recycling**  
1231 S. Sanderson Ave.  
(909) 933-2773

**Menlo Recycle Center**  
445 E. Menlo Ave.  
(951) 766-8520

**NexCycle**  
1295 S. State St.  
(800) 969-2020

**NexCycle**  
3125 W. Florida Ave.  
(800) 969-2020

**rePlanet**  
43396 US Hwy 74  
(877) 737-5263

**The Green Guys Recycling**  
100 N. State St., #101  
(951) 757-9156

**Valley Metals**  
342 N. Juanita St.  
(951) 925-8577

## Lake Elsinore

**Cans Plus Recycling**  
29170 Riverside Dr., #1  
(951) 245-1178

**Downtown Elsinore Recycling**  
217 N. Main St.  
(323) 204-8308

**Lake Elsinore Recycling Center**  
1315 W. Flint St.  
(951) 579-4102

**Love Earth Recycling**  
31949 Corydon Rd., #160  
(951) 230-6580

**NexCycle**  
31564 Grape St.  
(909) 796-2210

**rePlanet**  
32281 Mission Tr.  
(951) 520-1700

**rePlanet**  
16750 Lakeshore Dr.  
(877) 737-5263

## Menifee

**rePlanet**  
30125 Antelope Rd.  
(951) 520-1700

**rePlanet**  
25904 Newport Rd.  
(877) 737-5263

**Neill's Recycling**  
26026 Sherman Rd.  
(951) 514-8656

**NexCycle**  
27220 Sun City Blvd.  
(909) 796-2210

**Tire Stop and Recycling**  
27491 Ethanac Rd.  
(888) 515-1376

## Murrieta

**EarthWize Recycling**  
27826 Clinton Keith Rd.  
(909) 933-2773

**Go Green Murrieta Recycling**  
40645 Cal. Oaks Rd.  
(818) 220-9540

**Murrieta Recycling**  
38365 Innovation Ct., #1102-1105  
(951) 894-3094

**rePlanet**  
40473 Murrieta Hot Springs Rd.  
(951) 520-1700

**rePlanet**  
23801 Washington Ave.  
(951) 520-1700

**rePlanet**  
4100 Cal. Oaks Rd.  
(951) 520-1700

**rePlanet**  
39140 Winchester Ave.  
(951) 520-1700

**rePlanet**  
28047 Scott Rd.  
(877) 737-5263

**SA Recycling**  
41400 Date St.  
(951) 677-8586

## Perris

**A-1**  
24440 Hwy 74  
(951) 940-4224

**Ecology Auto Parts**  
23332 Cajalco Rd.  
(951) 657-7725

**Go Green Recycling**  
164 Malbert St., #A-2  
(951) 487-5875

**Harb Family Market Recycling**  
22707 San Jacinto Ave.  
(951) 657-7733

**4th Street Recycling**  
510 W. 4th St.  
(323) 204-8308

**Menlo Recycle Center**  
151 W. 7th St.  
(951) 657-8200

**RecycleWise**  
200 Sinclair St. #4  
(951) 443-1894

**Recycling Depot**  
1320 W. Oleander Ave.  
(951) 442-5221

**rePlanet**  
47 W. Nuevo Rd.  
(877) 737-5263

## San Jacinto

**CA Recycling**  
762 S. San Jacinto Ave.  
(951) 651-0010

**rePlanet**  
1271 N. State St.  
(877) 737-5263

**San Jacinto Recycling Center**  
658 W. Esplanade Ave.  
(951) 654-1399

## Temecula

**Heavy Metal Scrap Recycling Inc.**  
43136 Rancho Way  
(951) 693-4677

**NexCycle**  
29530 Rancho California Rd.  
(909) 796-2210

**NexCycle**  
26419 Ynez Rd.  
(909) 796-2210

**rePlanet**  
30530 Rancho California Rd.  
(951) 520-1700

**rePlanet**  
33293 Temecula Pkwy.  
(951) 520-1700

**rePlanet**  
31813 Temecula Pkwy.  
(877) 737-5263

**Temecula Recycling**  
27635 Diaz Rd., #120  
(951) 693-1500

## Wildomar

**rePlanet**  
23893 Clinton Keith Rd.  
(951) 520-1700

**rePlanet**  
30712 Benton Rd.  
(877) 737-5263

\*Some recycling centers may accept other recyclable materials. It is advisable to call the center and confirm this, as well as operating hours, before visiting.

For more information about local recycling centers visit the **CalRecycle** website: [www.calrecycle.ca.gov](http://www.calrecycle.ca.gov).

# Types of Plastic

# Composting Basics

**Confused about the types of plastic and if they can be recycled?** Many plastic containers display an identification code that indicates what they are made from. Below are the 7 codes.



**#1: Polyethylene Terephthalate (PETE or PET)**  
Used to create 2-liter soda bottles, water bottles, cooking oil bottles, peanut butter jars.  
*The most commonly accepted plastic for recycling.*



**#2: High Density Polyethylene**  
Used to create detergent bottles, milk and water jugs, grocery bags, yogurt cups.  
*Commonly accepted for recycling. Bags can be recycled at some large grocery stores.*



**#3: Polyvinyl Chloride**  
Used to create plastic pipes, outdoor furniture, shrink-wrap, liquid detergent containers, flooring, showercurtains.  
*Not currently accepted for recycling.*



**#4: Low Density Polyethylene**  
Used to create food storage containers, cellophane wrap, dry cleaning bags, produce bags, trash can liners.  
*Not commonly recycled, some large grocery stores accept LDPE bags.*



**#5: Polypropylene**  
Used to create ketchup bottles, aerosol caps, drinking straws, yogurt containers.  
*Not commonly accepted for recycling.*



**#6: Polystyrene**  
Also known as "Styrofoam." Used to make coffee cups, take-out food packaging, egg cartons, and packaging "peanuts."  
*Sometimes accepted for recycling and made into the same products.*



**#7: Other**  
All other plastic resins or a mixture of resins used to make reusable water bottles, Tupperware, biodegradable and compostable plastics  
*Not commonly accepted for recycling.*

**Got food scraps and yardwaste?** Below is a quick guide to Backyard Composting.

## 1. Select a good spot for composting

- Sun or shade
- Convenient to kitchen or garden, and close to a source of water
- Keep away from structures and wood, as moisture can hasten decay
- Place only on bare ground, as organisms from soil are needed

## 2. Know the Ingredients

**Nitrogen** - Green materials - grass clippings, fresh leaves and twigs, vegetable and fruit trimmings, coffee grounds and filters, and non-meat eating animal manures.

**Carbon** - Brown materials that have released their nitrogen - dry and brittle leaves and grasses, straw, wood chips, corn stalks, shredded newspaper, paper towels, napkins, and cardboard.

**Water** - The correct moisture level should be about the same as a damp wrung out sponge. A few drops should fall when squeezed in your hand.

**Air** - Oxygen is very important to the bacteria, fungi, and microorganisms that are working in the pile to breakdown the organic material.

**Do Not Add** - Meat, dairy products, fats, oils, waste from meat eating animals (dogs and cats), thorny plant material, or diseased plant material.

## 2. Know the Methods

**Aerobic** - Pile equal parts green and brown material on ground or in a bin in a 3'x3'x3' heap, water well, and cover with a tarp, carpet or opaque plastic sheet. The pile will heat up (120 to 160 degrees), and needs to be turned after a few days, once it has cooled. Turn the pile weekly and continue composting until the pile has a dark rich look like chocolate cake and the things you put in don't look like their original form. After the compost is done, water well, cover, and let it rest for one to two weeks to make sure it is completely done and the nitrogen has a chance to stabilize. If the compost is used too soon it could rob nutrients from the surrounding plants. Remove large chunks and add them to the next compost pile.

**Anerobic** - Similar to the Aerobic method, but there is no need to actively turn the material. It may take longer (1-2 years), but is still beneficial to your garden. Just pile the stuff, water, cover, and wait.

For more detailed information on composting, free workshops, or other methods, such as **Vermicomposting**, visit [www.rivcowm.org](http://www.rivcowm.org) and search for composting

# Source Reduction

**The best way to reduce waste is to prevent it!**

## Buy Responsibly

**Reduce packaging waste** - Look for products that reduce packaging, or purchase in bulk to reduce the amount of packaging needed.

**Look for products containing recycled material** - Recycled paper products, motor oil, and even pens and pencils are just a few examples of products that reduce waste.

**Consider reusable products** - Buy reusable water bottles and sturdy utensils and plates that can be washed and used again.

**Get it "For Here," or bring your own** - Many coffee shops will provide drinks to their customers in ceramic mugs rather than paper cups if requested. Just ask! Reusable tumblers are also a great alternative to paper cups, and many establishments will even give a small discount to those who bring their own!

**Borrow, rent, or share** - Why buy something if you are only going to use it once? Items such as tools, party decorations, and even newspapers and magazines can be shared with your friends, family, and/or community.

**Purchase rebuilt, remanufactured, or refurbished** - Many electronics such as cell phones, computers, and media players can be purchased "refurbished" at a sometimes substantial price reduction. This conserves the resources needed to manufacture a new product.

## Choose Non-Toxic

Choose products that contain only non-toxic materials, or try one of these **homemade alternatives**:

- Instead of glass cleaner, dilute 1 cup of vinegar in 1 quart of water.
- To open clogged drains, flush with a mixture of boiling water, and equal parts baking soda and vinegar.

For more information on non-toxic alternatives, visit the California Coastal Commission website:

[http:// www.coastal.ca.gov/ccbn/lesstoxic.html](http://www.coastal.ca.gov/ccbn/lesstoxic.html)

# Source Reduction

**Plastic bags and junk mail contribute to a significant amount of un-needed waste.** You can lessen their impact by Reducing, Reusing, and Recycling.



## Plastic Bags

**Reduce: BYOB (Bring Your Own Bag)** - Use reusable canvas or cloth bags rather than plastic bags, and keep them in your car. Not all items need a bag, just say "no, thank you."

**Reuse** - Plastic grocery bags can serve multiple purposes, such as trash can liners or for pet waste.

**Recycle** - If you find that you must use a plastic bag, recycle it when you are finished. Most large supermarkets and pharmacies offer free recycling of plastic bags.

## Junk Mail Reduction

You can reduce the amount of unwanted junk mail in your mailbox by simply mailing a postcard to the following addresses, requesting your name be removed from their mailing list. Be sure to include your full name, your address(es), your signature, and the date.

Mail Preference Service  
Attn.: Dept. 10088342  
PO Box 282  
Carmel, NY 10512

ADVO  
Consumer Assistance  
PO Box 249  
Windsor, CT 06095

Harte-Hanks Circulation  
C/O Pennysaver  
2830 Orbiter St.  
Brea, CA 92821

Valpak Direct Marketing Systems, Inc.  
8605 Largo Lakes Dr.  
Largo, FL 33773

Credit Card Junk Mail  
Call (888)5-OPT OUT (888-567-8688)

## City / County Resources

**City of Canyon Lake - Waste and Recycling** | (800) 755-8112

[http:// www.cityofcanyonlake.com/recycling.asp](http://www.cityofcanyonlake.com/recycling.asp)

**City of Hemet - Integrated Waste Management** | (951) 765-3712

[http:// www.cityofhemet.org/index.aspx?nid=93](http://www.cityofhemet.org/index.aspx?nid=93)

**City of Lake Elsinore - Recycling** | (951) 674-3124

[http:// www.lake-elsinore.org/index.aspx?page=751](http://www.lake-elsinore.org/index.aspx?page=751)

**City of Menifee - Public Works Department** | (951) 672-6777

[http:// www.cityofmenifee.us/index.aspx?nid=99](http://www.cityofmenifee.us/index.aspx?nid=99)

**City of Murrieta - Trash & Recycling** | (951) 461-6007

[http:// www.murrieta.org/services/trash](http://www.murrieta.org/services/trash)

**City of Perris - Waste & Recycling** | (951) 943-6100

[http:// www.cityofperris.org/residents/waste-recycle.html](http://www.cityofperris.org/residents/waste-recycle.html)

**City of San Jacinto - Waste & Recycling** | (951) 487-7330

[http:// www.san-jacinto.ca.us/residents/waste.html](http://www.san-jacinto.ca.us/residents/waste.html)

**City of Temecula - Trash & Recycling** | 951-694-6444

[http:// www.cityoftemecula.org/temecula/residents/trashrecycling/recycling.htm](http://www.cityoftemecula.org/temecula/residents/trashrecycling/recycling.htm)

**City of Wildomar - Trash Hauling and Recycling** | (951) 677-7751

[http:// www.cityofwildomar.org/trash-hauling-recycling.asp](http://www.cityofwildomar.org/trash-hauling-recycling.asp)

**County of Riverside - Riverside County Waste Management Department**

[http:// www.rivcowm.org](http://www.rivcowm.org) | (951) 486-3200

**Western Riverside Council of Governments**

[http:// www.wrcog.cog.ca.us](http://www.wrcog.cog.ca.us) | (800) 350-4645

## Waste Haulers

**Waste Management, Inc.** - (951) 280-5400 - [www.wm.com](http://www.wm.com)

Serves: Menifee, Murrieta, and Wildomar

**CR&R Disposal** - (951) 943-1991 - [www.crrwasteservices.com](http://www.crrwasteservices.com)

Serves: Canyon Lake, Hemet, Lake Elsinore, Perris, San Jacinto, and Temecula

**The Complete Guide to Residential Recycling is sponsored by:**





# A Citizen's Guide to Understanding Stormwater



EPA  
United States Environmental Protection Agency

EPA 833-B-03-002

January 2003

Internet Address (URL): <http://www.epa.gov>  
Oil Based Inks on 100% Postconsumer Recycled Paper • Printed with Vegetable Process Chlorine Free Recycled Paper



## After the Storm

For more information contact:  
[www.epa.gov/nps/stormwater](http://www.epa.gov/nps/stormwater)  
or visit  
[www.epa.gov/nps](http://www.epa.gov/nps)



### What is stormwater runoff?



Stormwater runoff occurs when precipitation from rain or snowmelt flows over the ground. Impervious surfaces like driveways, sidewalks, and streets prevent stormwater from naturally soaking into the ground.

### Why is stormwater runoff a problem?



Stormwater can pick up debris, chemicals, dirt, and other pollutants and flow into a storm sewer system or directly to a lake, stream, river, wetland, or coastal water. Anything that enters a storm sewer system is discharged untreated into the waterbodies we use for swimming, fishing, and providing drinking water.

### The effects of pollution

Polluted stormwater runoff can have many adverse effects on plants, fish, animals, and people.



- ◆ Sediment can cloud the water and make it difficult or impossible for aquatic plants to grow. Sediment also can destroy aquatic habitats.
- ◆ Excess nutrients can cause algae blooms. When algae die, they sink to the bottom and decompose in a process that removes oxygen from the water. Fish and other aquatic organisms can't exist in water with low dissolved oxygen levels.
- ◆ Bacteria and other pathogens can wash into swimming areas and create health hazards, often making beach closures necessary.
- ◆ Debris—plastic bags, six-pack rings, bottles, and cigarette butts—washed into waterbodies can choke, suffocate, or disable aquatic life like ducks, fish, turtles, and birds.
- ◆ Household hazardous wastes like insecticides, pesticides, paint, solvents, used motor oil, and other auto fluids can poison aquatic life. Land animals and people can become sick or die from eating diseased fish and shellfish or ingesting polluted water.



◆ Polluted stormwater often affects drinking water sources. This, in turn, can affect human health and increase drinking water treatment costs.



# Stormwater Pollution Solutions

## Residential

Recycle or properly dispose of household products that contain chemicals, such as insecticides, pesticides, paint, solvents, and used motor oil and other auto fluids. Don't pour them onto the ground or into storm drains.

### Lawn care

Excess fertilizers and pesticides applied to lawns and gardens wash off and pollute streams. In addition, yard clippings and leaves can wash into storm drains and contribute nutrients and organic matter to streams.



- ◆ Don't overwater your lawn. Consider using a soaker hose instead of a sprinkler.
- ◆ Use pesticides and fertilizers sparingly. When use is necessary, use these chemicals in the recommended amounts. Use organic mulch or safer pest control methods whenever possible.
- ◆ Compost or mulch yard waste. Don't leave it in the street or sweep it into storm drains or streams.
- ◆ Cover piles of dirt or mulch being used in landscaping projects.

### Septic systems

Leaking and poorly maintained septic systems release nutrients and pathogens (bacteria and viruses) that can be picked up by stormwater and discharged into nearby waterbodies. Pathogens can cause public health problems and environmental concerns.



- ◆ Inspect your system every 3 years and pump your tank as necessary (every 3 to 5 years).
- ◆ Don't dispose of household hazardous waste in sinks or toilets.

### Auto care

Washing your car and degreasing auto parts at home can send detergents and other contaminants through the storm sewer system. Dumping automotive fluids into storm drains has the same result as dumping the materials directly into a waterbody.



- ◆ Use a commercial car wash that treats or recycles its wastewater, or wash your car on your yard so the water infiltrates into the ground.
- ◆ Repair leaks and dispose of used auto fluids and batteries at designated drop-off or recycling locations.

### Pet waste

Pet waste can be a major source of bacteria and excess nutrients in local waters.



- ◆ When walking your pet, remember to pick up the waste and dispose of it properly. Flushing pet waste is the best disposal method. Leaving pet waste on the ground increases public health risks by allowing harmful bacteria and nutrients to wash into the storm drain and eventually into local waterbodies.



Education is essential to changing people's behavior. Signs and markers near storm drains warn residents that pollutants entering the drains will be carried untreated into a local waterbody.

## Residential landscaping

**Permeable Pavement**—Traditional concrete and asphalt don't allow water to soak into the ground. Instead these surfaces rely on storm drains to divert unwanted water. Permeable pavement systems allow rain and snowmelt to soak through, decreasing stormwater runoff.

**Rain Barrels**—You can collect rainwater from rooftops in mosquito-proof containers. The water can be used later on lawn or garden areas.

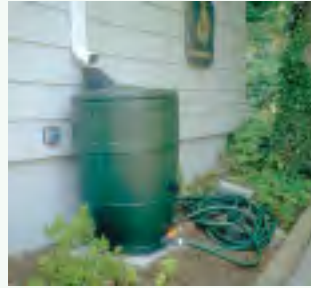

**Rain Gardens and Grassy Swales**—Specially designed areas planted with native plants can provide natural places for rainwater to collect and soak into the ground. Rain from rooftop areas or paved areas can be diverted into these areas rather than into storm drains.



**Vegetated Filter Strips**—Filter strips are areas of native grass or plants created along roadways or streams. They trap the pollutants stormwater picks up as it flows across driveways and streets.

## Commercial

Dirt, oil, and debris that collect in parking lots and paved areas can be washed into the storm sewer system and eventually enter local waterbodies.

- ◆ Sweep up litter and debris from sidewalks, driveways and parking lots, especially around storm drains.
- ◆ Cover grease storage and dumpsters and keep them clean to avoid leaks.
- ◆ Report any chemical spill to the local hazardous waste cleanup team. They'll know the best way to keep spills from harming the environment.

Erosion controls that aren't maintained can cause excessive amounts of sediment and debris to be carried into the stormwater system. Construction vehicles can leak fuel, oil, and other harmful fluids that can be picked up by stormwater and deposited into local waterbodies.

- ◆ Divert stormwater away from disturbed or exposed areas of the construction site.
- ◆ Install silt fences, vehicle mud removal areas, vegetative cover, and other sediment and erosion controls and properly maintain them, especially after rainstorms.
- ◆ Prevent soil erosion by minimizing disturbed areas during construction projects, and seed and mulch bare areas as soon as possible.

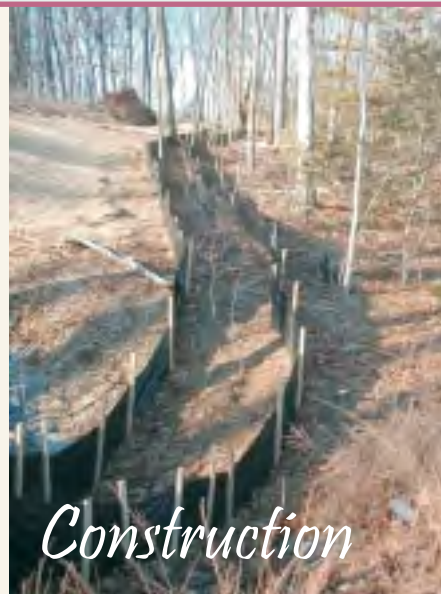

## Construction

## Agriculture

Lack of vegetation on streambanks can lead to erosion. Overgrazed pastures can also contribute excessive amounts of sediment to local waterbodies. Excess fertilizers and pesticides can poison aquatic animals and lead to destructive algae blooms. Livestock in streams can contaminate waterways with bacteria, making them unsafe for human contact.

- ◆ Keep livestock away from streambanks and provide them a water source away from waterbodies.
- ◆ Store and apply manure away from waterbodies and in accordance with a nutrient management plan.
- ◆ Vegetate riparian areas along waterways.
- ◆ Rotate animal grazing to prevent soil erosion in fields.
- ◆ Apply fertilizers and pesticides according to label instructions to save money and minimize pollution.



## Forestry

Improperly managed logging operations can result in erosion and sedimentation.

- ◆ Conduct preharvest planning to prevent erosion and lower costs.
- ◆ Use logging methods and equipment that minimize soil disturbance.
- ◆ Plan and design skid trails, yard areas, and truck access roads to minimize stream crossings and avoid disturbing the forest floor.
- ◆ Construct stream crossings so that they minimize erosion and physical changes to streams.
- ◆ Expedite revegetation of cleared areas.

## Automotive Facilities

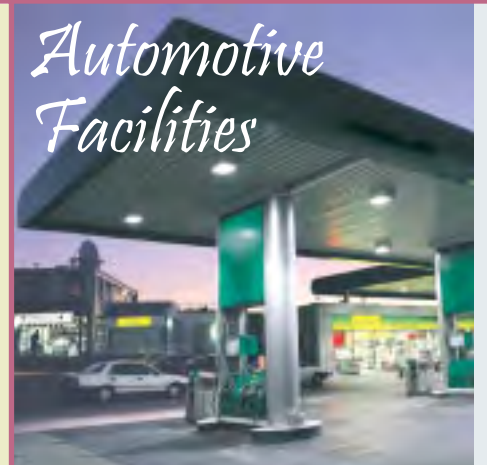

Uncovered fueling stations allow spills to be washed into storm drains. Cars waiting to be repaired can leak fuel, oil, and other harmful fluids that can be picked up by stormwater.

- ◆ Clean up spills immediately and properly dispose of cleanup materials.
- ◆ Provide cover over fueling stations and design or retrofit facilities for spill containment.
- ◆ Properly maintain fleet vehicles to prevent oil, gas, and other discharges from being washed into local waterbodies.
- ◆ Install and maintain oil/water separators.

## BIORETENTION BASIN CONSTRUCTION

---

1. The engineer shall furnish to the County a copy of the source testing and a signed certification that the fully blended Bioretention/Biofiltration Soil Media (BSM) material meets all of the WQMP requirements before material is imported or if the material is mixed onsite prior to installation.
2. As BSM material is being installed, Quality Assurance (QA) tests shall be conducted or for every 1,200 tons or 800 cubic yards mixed on-site from a completely mixed stockpile or windrow, with a minimum of three tests. For imported material from a supplier with a quality control program the QA tests shall be conducted 2,400 tons or 1,600 cubic yards from the supplier.
3. The Engineer conducting the Quality Control testing shall furnish to the County copy of the QA testing and a certification that the BSM for the project meets all of the following requirements. Certified mitigation plans can be used for exceedances, as long as all the requirements are designed to be met.
  - a. BSM shall not be compacted. BSM shall consist of 60–80% clean sand, up to 20% clean topsoil, and 20% of a nutrient-stabilized organic amendment. The initial infiltration rate shall be greater than 8 inches per hour per laboratory test.
  - b. pH: 6.0 – 8.8; Salinity: 0.5 to 3.0 mmh<sub>0</sub>/cm as electrical conductivity; Sodium absorption ratio: < 6.0; Chloride: < 800ppm in saturated extract; Cation Exchange Capacity (CEC): > 10meq/100g; Organic Matter: 2 to 5-percent on a dry weight basis; Carbon:Nitrogen Ratio: 12 to 40, preferably 15 to 40; Gravel larger than 2mm: 0 to 25-percent of the total sample; Clay smaller than 0.005mm: 0 to 5 percent of the non-gravel fraction.
  - c. BSM shall be tested to limit the leaching of potential inherent pollutants. BSM used in Biofiltration BMPs shall conform to the following limits for pollutant concentrations in saturated extract: Phosphorus: < 1mg/L; Nitrate < 3mg/L, Copper < 0.025mg/L. These pollutant limits are for the amount that is leached from the sample, not from the soil sample itself. Testing may be performed after laboratory rinsing of media with up to 15 pore volumes of water. Equivalent test results will be accepted if certified by a laboratory or appropriate testing facility.
  - d. Low nutrient compost used in BSM shall be sourced from a facility permitted through CalRecycle, preferably through USCC STA program. Compost shall conform to the following requirements: Physical contaminants < 1% by dry weight; Carbon:Nitrogen ratio 12:1 to 40:1; Maturity/Stability shall conform to either: Solvita Maturity Index: ≥ 5.5, CO<sub>2</sub> Evolution: < 2.5 mg CO<sub>2</sub>-C per g compost organic matter per day, or < 5mg CO<sub>2</sub>-C per g compost C per day; Select Pathogens and trace metals shall pass US EPA Class A Standard. Testing shall be no more than 6 months old and representative of current stock piles.
  - e. Coconut coir pith used in BSM shall be thoroughly rinsed with freshwater and screened to remove coarse fibers as part of production and aged > 6 months. Peat used in BSM shall be sphagnum peat.

## General Description

Vortex separators: (alternatively, swirl concentrators) are gravity separators, and in principle are essentially wet vaults. The difference from wet vaults, however, is that the vortex separator is round, rather than rectangular, and the water moves in a centrifugal fashion before exiting. By having the water move in a circular fashion, rather than a straight line as is the case with a standard wet vault, it is possible to obtain significant removal of suspended sediments and attached pollutants with less space. Vortex separators were originally developed for combined sewer overflows (CSOs), where it is used primarily to remove coarse inorganic solids. Vortex separation has been adapted to stormwater treatment by several manufacturers.

## Inspection/Maintenance Considerations

As some of the systems have standing water that remains between storms, there is concern about mosquito breeding. Also, a loss of dissolved pollutants may occur as accumulated organic matter (e.g., leaves) decomposes in the units.

Inspection Activities	Suggested Frequency
<ul style="list-style-type: none"> <li>■ Inspect for accumulated sediment/debris.</li> </ul>	As needed
Maintenance Activities	Suggested Frequency
<ul style="list-style-type: none"> <li>■ Remove of accumulated material with an eductor truck. It may be necessary to remove and dispose the floatables separately due to the presence of petroleum product.</li> </ul>	Annual, or more frequent as needed

## Maintenance Concerns, Objectives, and Goals

- Sediment/Debris Removal
- Vector Control

## Targeted Constituents

- ✓ Sediment ▲
- ✓ Nutrients ●
- ✓ Trash
- ✓ Metals ●
- Bacteria
- ✓ Oil and Grease
- ✓ Organics

### Legend (Removal Effectiveness)

- Low
- High
- ▲ Medium



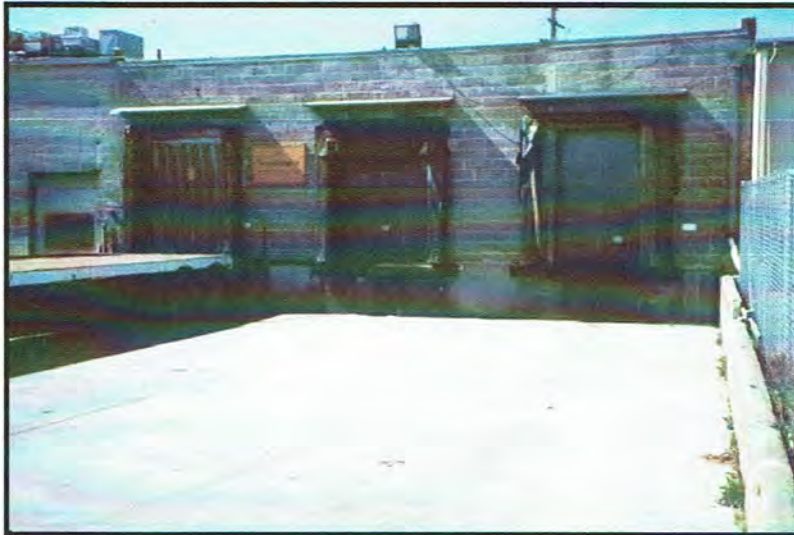

## Objectives

- Cover
- Contain
- Educate
- Reduce/Minimize
- Product Substitution

## Description

The loading/unloading of materials usually takes place outside on docks or terminals; therefore, materials spilled, leaked, or lost during loading/unloading may collect in the soil or on other surfaces and have the potential to be carried away by stormwater runoff or when the area is cleaned. Additionally, rainfall may wash pollutants from machinery used to unload or move materials. Implementation of the following protocols will prevent or reduce the discharge of pollutants to stormwater from outdoor loading/unloading of materials.

## Approach

Reduce potential for pollutant discharge through source control pollution prevention and BMP implementation. Successful implementation depends on effective training of employees on applicable BMPs and general pollution prevention strategies and objectives.

## Pollution Prevention

- Keep accurate maintenance logs to evaluate materials removed and improvements made.
- Park tank trucks or delivery vehicles in designated areas so that spills or leaks can be contained.
- Limit exposure of material to rainfall whenever possible.
- Prevent stormwater run-on.
- Check equipment regularly for leaks.

## Targeted Constituents

Sediment	✓
Nutrients	✓
Trash	
Metals	✓
Bacteria	
Oil and Grease	✓
Organics	✓



***Suggested Protocols******Loading and Unloading – General Guidelines***

- Develop an operations plan that describes procedures for loading and/or unloading.
- Conduct loading and unloading in dry weather if possible.
- Cover designated loading/unloading areas to reduce exposure of materials to rain.
- Consider placing a seal or door skirt between delivery vehicles and building to prevent exposure to rain.
- Design loading/unloading area to prevent stormwater run-on, which would include grading or berming the area, and position roof downspouts so they direct stormwater away from the loading/unloading areas.
- Have employees load and unload all materials and equipment in covered areas such as building overhangs at loading docks if feasible.
- Load/unload only at designated loading areas.
- Use drip pans underneath hose and pipe connections and other leak-prone spots during liquid transfer operations, and when making and breaking connections. Several drip pans should be stored in a covered location near the liquid transfer area so that they are always available, yet protected from precipitation when not in use. Drip pans can be made specifically for railroad tracks. Drip pans must be cleaned periodically, and drip collected materials must be disposed of properly.
- Pave loading areas with concrete instead of asphalt.
- Avoid placing storm drains in the area.
- Grade and/or berm the loading/unloading area to a drain that is connected to a deadend.

***Inspection***

- Check loading and unloading equipment regularly for leaks, including valves, pumps, flanges and connections.
- Look for dust or fumes during loading or unloading operations.

***Training***

- Train employees (e.g., fork lift operators) and contractors on proper spill containment and cleanup.
- Have employees trained in spill containment and cleanup present during loading/unloading.
- Train employees in proper handling techniques during liquid transfers to avoid spills.
- Make sure forklift operators are properly trained on loading and unloading procedures.

## ***Spill Response and Prevention***

- Keep your Spill Prevention Control and Countermeasure (SPCC) Plan up-to-date.
- Contain leaks during transfer.
- Store and maintain appropriate spill cleanup materials in a location that is readily accessible and known to all and ensure that employees are familiar with the site's spill control plan and proper spill cleanup procedures.
- Have an emergency spill cleanup plan readily available.
- Use drip pans or comparable devices when transferring oils, solvents, and paints.

## ***Other Considerations (Limitations and Regulations)***

- Space and time limitations may preclude all transfers from being performed indoors or under cover.
- It may not be possible to conduct transfers only during dry weather.

## **Requirements**

### ***Costs***

Costs should be low except when covering a large loading/unloading area.

### ***Maintenance***

- Conduct regular inspections and make repairs as necessary. The frequency of repairs will depend on the age of the facility.
- Check loading and unloading equipment regularly for leaks.
- Conduct regular broom dry-sweeping of area.

## **Supplemental Information**

### ***Further Detail of the BMP***

#### ***Special Circumstances for Indoor Loading/Unloading of Materials***

Loading or unloading of liquids should occur in the manufacturing building so that any spills that are not completely retained can be discharged to the sanitary sewer, treatment plant, or treated in a manner consistent with local sewer authorities and permit requirements.

- For loading and unloading tank trucks to above and below ground storage tanks, the following procedures should be used:
  - The area where the transfer takes place should be paved. If the liquid is reactive with the asphalt, Portland cement should be used to pave the area.
  - The transfer area should be designed to prevent run-on of stormwater from adjacent areas. Sloping the pad and using a curb, like a speed bump, around the uphill side of the transfer area should reduce run-on.

- The transfer area should be designed to prevent runoff of spilled liquids from the area. Sloping the area to a drain should prevent runoff. The drain should be connected to a dead-end sump or to the sanitary sewer. A positive control valve should be installed on the drain.
- For transfer from rail cars to storage tanks that must occur outside, use the following procedures:
  - Drip pans should be placed at locations where spillage may occur, such as hose connections, hose reels, and filler nozzles. Use drip pans when making and breaking connections.
  - Drip pan systems should be installed between the rails to collect spillage from tank cars.

**References and Resources**

California's Nonpoint Source Program Plan <http://www.swrcb.ca.gov/nps/index.html>

Clark County Storm Water Pollution Control Manual  
<http://www.co.clark.wa.us/pubworks/bmpman.pdf>

King County Storm Water Pollution Control Manual <http://dnr.metrokc.gov/wlr/dss/spcm.htm>

Santa Clara Valley Urban Runoff Pollution Prevention Program <http://www.securppp.org>

The Storm Water Managers Resource Center <http://www.stormwatercenter.net/>

## Description

Promote the use of less harmful products and products that contain little or no TMDL pollutants. Alternatives exist for most product classes including chemical fertilizers, pesticides, cleaning solutions, janitorial chemicals, automotive and paint products, and consumables (batteries, fluorescent lamps).

## Approach

Pattern a new program after the many established programs around the state and country. Integrate this best management practice as much as possible with existing programs at your facility.

Develop a comprehensive program based on:

- The "Precautionary Principle," which is an alternative to the "Risk Assessment" model that says it's acceptable to use a potentially harmful product until physical evidence of its harmful effects are established and deemed too costly from an environmental or public health perspective. For instance, a risk assessment approach might say it's acceptable to use a pesticide until there is direct proof of an environmental impact. The Precautionary Principle approach is used to evaluate whether a given product is safe, whether it is really necessary, and whether alternative products would perform just as well.
- Environmentally Preferable Purchasing Program to minimize the purchase of products containing hazardous ingredients used in the facility's custodial services, fleet maintenance, and facility maintenance in favor of using alternate products that pose less risk to employees and to the environment.
- Integrated Pest Management (IPM) or Less-Toxic Pesticide Program, which uses a pest management approach that minimizes the use of toxic chemicals and gets rid of pests by methods that pose a lower risk to employees, the public, and the environment.
- Energy Efficiency Program including no-cost and low-cost energy conservation and efficiency actions that can reduce both energy consumption and electricity bills, along with long-term energy efficiency investments.

Consider the following mechanisms for developing and implementing a comprehensive program:

- Policies

## Objectives

- Educate
- Reduce/Minimize
- Product Substitution

## Targeted Constituents

Sediment	
Nutrients	✓
Trash	
Metals	✓
Bacteria	
Oil and Grease	✓
Organics	✓



- Procedures
  - Standard operating procedures (SOPs)
  - Purchasing guidelines and procedures
  - Bid packages (services and supplies)
- Materials
  - Preferred or approved product and supplier lists
  - Product and supplier evaluation criteria
  - Training sessions and manuals
  - Fact sheets for employees

Implement this BMP in conjunction with the Vehicle and Equipment Management fact sheets (SC20 – SC22) and SC41, Building and Grounds Maintenance.

***Training***

- Employees who handle potentially harmful materials in the use of safer alternatives.
- Purchasing departments should be encouraged to procure less hazardous materials and products that contain little or no harmful substances or TMDL pollutants.

***Regulations***

This BMP has no regulatory requirements. Existing regulations already encourage facilities to reduce the use of hazardous materials through incentives such as reduced:

- Specialized equipment storage and handling requirements,
- Storm water runoff sampling requirements,
- Training and licensing requirements, and
- Record keeping and reporting requirements.

***Equipment***

- There are no major equipment requirements to this BMP.

***Limitations***

- Alternative products may not be available, suitable, or effective in every case.

**Requirements*****Cost Considerations***

- The primary cost is for staff time to: 1) develop new policies and procedures and 2) educate purchasing departments and employees who handle potentially harmful materials about the availability, procurement, and use of safer alternatives.

- Some alternative products may be slightly more expensive than conventional products.

## Supplemental Information

Employees and contractors / service providers can both be educated about safer alternatives by using information developed by a number of organizations including the references and resources listed below.

The following discussion provides some general information on safer alternatives. More specific information on particular hazardous materials and the available alternatives may be found in the references and resources listed below.

- Automotive products – Less toxic alternatives are not available for many automotive products, especially engine fluids. But there are alternatives to grease lubricants, car polishes, degreasers, and windshield washer solution. Rerefined motor oil is also available.
- Vehicle/Trailer lubrication – Fifth wheel bearings on trucks require routine lubrication. Adhesive lubricants are available to replace typical chassis grease.
- Cleaners – Vegetables-based or citrus-based soaps are available to replace petroleum-based soaps/detergents.
- Paint products – Water-based paints, wood preservatives, stains, and finishes are available.
- Pesticides – Specific alternative products or methods exist to control most insects, fungi, and weeds.
- Chemical Fertilizers – Compost and soil amendments are natural alternatives.
- Consumables – Manufacturers have either reduced or are in the process of reducing the amount of heavy metals in consumables such as batteries and fluorescent lamps. All fluorescent lamps contain mercury, however low-mercury containing lamps are now available from most hardware and lighting stores. Fluorescent lamps are also more energy efficient than the average incandescent lamp.
- Janitorial chemicals – Even biodegradable soap can harm fish and wildlife before it biodegrades. Biodegradable does not mean non-toxic. Safer products and procedures are available for floor stripping and cleaning, as well as carpet, glass, metal, and restroom cleaning and disinfecting.

## Examples

There are a number of business and trade associations, and communities with effective programs. Some of the more prominent are listed below in the references and resources section.

## References and Resources

Note: Many of these references provide alternative products for materials that typically are used inside and disposed to the sanitary sewer as well as alternatives to products that usually end up in the storm drain.

***General Sustainable Practices and Pollution Prevention Including Pollutant-Specific Information***

California Department of Toxic Substances Control ([www.dtsc.ca.gov](http://www.dtsc.ca.gov))

California Integrated Waste Management Board ([www.ciwmb.ca.gov](http://www.ciwmb.ca.gov))

City of Santa Monica ([www.santa-monica.org/environment](http://www.santa-monica.org/environment))

City of Palo Alto ([www.city.palo-alto.ca.us/cleanbay](http://www.city.palo-alto.ca.us/cleanbay))

City and County of San Francisco, Department of the Environment  
([www.ci.sf.ca.us/sfenvironment](http://www.ci.sf.ca.us/sfenvironment))

Earth 911 ([www.earth911.org/master.asp](http://www.earth911.org/master.asp))

Environmental Finance Center Region IX ([www.greenstart.org/efc9](http://www.greenstart.org/efc9))

Flex Your Power ([www.flexyourpower.ca.gov](http://www.flexyourpower.ca.gov))

GreenBiz.com ([www.greenbiz.com](http://www.greenbiz.com))

Green Business Program ([www.abag.org/bayarea/enviro/gbus/gb.html](http://www.abag.org/bayarea/enviro/gbus/gb.html))

Pacific Industrial and Business Association ([www.piba.org](http://www.piba.org))

Sacramento Clean Water Business Partners ([www.sacstormwater.org](http://www.sacstormwater.org))

USEPA BMP fact sheet – Alternative products  
([http://cfpub.epa.gov/npdes/stormwater/menuofbmps/poll\\_2.cfm](http://cfpub.epa.gov/npdes/stormwater/menuofbmps/poll_2.cfm))

USEPA Region IX Pollution Prevention Program ([www.epa.gov/region09/p2](http://www.epa.gov/region09/p2))

Western Regional Pollution Prevention Network ([www.westp2net.org](http://www.westp2net.org))

***Metals (mercury, copper)***

National Electrical Manufacturers Association - Environment, Health and Safety  
([www.nema.org](http://www.nema.org))

Sustainable Conservation ([www.suscon.org](http://www.suscon.org))

Auto Recycling Project

Brake Pad Partnership

***Pesticides and Chemical Fertilizers***

Bio-Integral Resource Center ([www.birc.org](http://www.birc.org))

California Department of Pesticide Regulation ([www.cdpr.ca.gov](http://www.cdpr.ca.gov))

University of California Statewide IPM Program ([www.ipm.ucdavis.edu/default.html](http://www.ipm.ucdavis.edu/default.html))

## *Dioxins*

Bay Area Dioxins Project (<http://dioxin.abag.ca.gov/>)



## Description

Stormwater runoff from building and grounds maintenance activities can be contaminated with toxic hydrocarbons in solvents, fertilizers and pesticides, suspended solids, heavy metals, abnormal pH, and oils and greases. Utilizing the protocols in this fact sheet will prevent or reduce the discharge of pollutants to stormwater from building and grounds maintenance activities by washing and cleaning up with as little water as possible, following good landscape management practices, preventing and cleaning up spills immediately, keeping debris from entering the storm drains, and maintaining the stormwater collection system.

## Approach

Reduce potential for pollutant discharge through source control pollution prevention and BMP implementation. Successful implementation depends on effective training of employees on applicable BMPs and general pollution prevention strategies and objectives.

## Pollution Prevention

- Switch to non-toxic chemicals for maintenance when possible.
- Choose cleaning agents that can be recycled.
- Encourage proper lawn management and landscaping, including use of native vegetation.

## Objectives

- Cover
- Contain
- Educate
- Reduce/Minimize
- Product Substitution

## Targeted Constituents

Sediment	✓
Nutrients	✓
Trash	
Metals	✓
Bacteria	✓
Oil and Grease	
Organics	



# SC-41 Building & Grounds Maintenance

---

- Encourage use of Integrated Pest Management techniques for pest control.
- Encourage proper onsite recycling of yard trimmings.
- Recycle residual paints, solvents, lumber, and other material as much as possible.

## ***Suggested Protocols***

### *Pressure Washing of Buildings, Rooftops, and Other Large Objects*

- In situations where soaps or detergents are used and the surrounding area is paved, pressure washers must use a water collection device that enables collection of wash water and associated solids. A sump pump, wet vacuum or similarly effective device must be used to collect the runoff and loose materials. The collected runoff and solids must be disposed of properly.
- If soaps or detergents are not used, and the surrounding area is paved, wash runoff does not have to be collected but must be screened. Pressure washers must use filter fabric or some other type of screen on the ground and/or in the catch basin to trap the particles in wash water runoff.
- If you are pressure washing on a grassed area (with or without soap), runoff must be dispersed as sheet flow as much as possible, rather than as a concentrated stream. The wash runoff must remain on the grass and not drain to pavement.

### *Landscaping Activities*

- Dispose of grass clippings, leaves, sticks, or other collected vegetation as garbage, or by composting. Do not dispose of collected vegetation into waterways or storm drainage systems.
- Use mulch or other erosion control measures on exposed soils.

### *Building Repair, Remodeling, and Construction*

- Do not dump any toxic substance or liquid waste on the pavement, the ground, or toward a storm drain.
- Use ground or drop cloths underneath outdoor painting, scraping, and sandblasting work, and properly dispose of collected material daily.
- Use a ground cloth or oversized tub for activities such as paint mixing and tool cleaning.
- Clean paintbrushes and tools covered with water-based paints in sinks connected to sanitary sewers or in portable containers that can be dumped into a sanitary sewer drain. Brushes and tools covered with non-water-based paints, finishes, or other materials must be cleaned in a manner that enables collection of used solvents (e.g., paint thinner, turpentine, etc.) for recycling or proper disposal.
- Use a storm drain cover, filter fabric, or similarly effective runoff control mechanism if dust, grit, wash water, or other pollutants may escape the work area and enter a catch basin. This is particularly necessary on rainy days. The containment device(s) must be in place at the beginning of the work day, and accumulated dirty runoff and solids must be collected and disposed of before removing the containment device(s) at the end of the work day.

# **Building & Grounds Maintenance SC-41**

---

- If you need to de-water an excavation site, you may need to filter the water before discharging to a catch basin or off-site. If directed off-site, you should direct the water through hay bales and filter fabric or use other sediment filters or traps.
- Store toxic material under cover during precipitation events and when not in use. A cover would include tarps or other temporary cover material.

## *Mowing, Trimming, and Planting*

- Dispose of leaves, sticks, or other collected vegetation as garbage, by composting or at a permitted landfill. Do not dispose of collected vegetation into waterways or storm drainage systems.
- Use mulch or other erosion control measures when soils are exposed.
- Place temporarily stockpiled material away from watercourses and drain inlets, and berm or cover stockpiles to prevent material releases to the storm drain system.
- Consider an alternative approach when bailing out muddy water: do not put it in the storm drain; pour over landscaped areas.
- Use hand weeding where practical.

## *Fertilizer and Pesticide Management*

- Follow all federal, state, and local laws and regulations governing the use, storage, and disposal of fertilizers and pesticides and training of applicators and pest control advisors.
- Use less toxic pesticides that will do the job when applicable. Avoid use of copper-based pesticides if possible.
- Do not use pesticides if rain is expected.
- Do not mix or prepare pesticides for application near storm drains.
- Use the minimum amount needed for the job.
- Calibrate fertilizer distributors to avoid excessive application.
- Employ techniques to minimize off-target application (e.g., spray drift) of pesticides, including consideration of alternative application techniques.
- Apply pesticides only when wind speeds are low.
- Fertilizers should be worked into the soil rather than dumped or broadcast onto the surface.
- Irrigate slowly to prevent runoff and then only as much as is needed.
- Clean pavement and sidewalk if fertilizer is spilled on these surfaces before applying irrigation water.
- Dispose of empty pesticide containers according to the instructions on the container label.

# **SC-41 Building & Grounds Maintenance**

---

- Use up the pesticides. Rinse containers, and use rinse water as product. Dispose of unused pesticide as hazardous waste.
- Implement storage requirements for pesticide products with guidance from the local fire department and County Agricultural Commissioner. Provide secondary containment for pesticides.

## *Inspection*

- Inspect irrigation system periodically to ensure that the right amount of water is being applied and that excessive runoff is not occurring. Minimize excess watering and repair leaks in the irrigation system as soon as they are observed.

## *Training*

- Educate and train employees on pesticide use and in pesticide application techniques to prevent pollution.
- Train employees and contractors in proper techniques for spill containment and cleanup.
- Be sure the frequency of training takes into account the complexity of the operations and the nature of the staff.

## *Spill Response and Prevention*

- Keep your Spill Prevention Control and Countermeasure (SPCC) Plan up-to-date.
- Place a stockpile of spill cleanup materials, such as brooms, dustpans, and vacuum sweepers (if desired) near the storage area where it will be readily accessible.
- Have employees trained in spill containment and cleanup present during the loading/unloading of dangerous wastes, liquid chemicals, or other materials.
- Familiarize employees with the Spill Prevention Control and Countermeasure Plan.
- Clean up spills immediately.

## *Other Considerations*

Alternative pest/weed controls may not be available, suitable, or effective in many cases.

## **Requirements**

### *Costs*

- Cost will vary depending on the type and size of facility.
- Overall costs should be low in comparison to other BMPs.

### *Maintenance*

Sweep paved areas regularly to collect loose particles. Wipe up spills with rags and other absorbent material immediately, do not hose down the area to a storm drain.

## Supplemental Information

### *Further Detail of the BMP*

#### *Fire Sprinkler Line Flushing*

Building fire sprinkler line flushing may be a source of non-stormwater runoff pollution. The water entering the system is usually potable water, though in some areas it may be non-potable reclaimed wastewater. There are subsequent factors that may drastically reduce the quality of the water in such systems. Black iron pipe is usually used since it is cheaper than potable piping, but it is subject to rusting and results in lower quality water. Initially, the black iron pipe has an oil coating to protect it from rusting between manufacture and installation; this will contaminate the water from the first flush but not from subsequent flushes. Nitrates, polyphosphates and other corrosion inhibitors, as well as fire suppressants and antifreeze may be added to the sprinkler water system. Water generally remains in the sprinkler system a long time (typically a year) and between flushes may accumulate iron, manganese, lead, copper, nickel, and zinc. The water generally becomes anoxic and contains living and dead bacteria and breakdown products from chlorination. This may result in a significant BOD problem and the water often smells. Consequently dispose fire sprinkler line flush water into the sanitary sewer. Do not allow discharge to storm drain or infiltration due to potential high levels of pollutants in fire sprinkler line water.

## References and Resources

California's Nonpoint Source Program Plan <http://www.swrcb.ca.gov/nps/index.html>

Clark County Storm Water Pollution Control Manual  
<http://www.co.clark.wa.us/pubworks/bmpman.pdf>

King County Storm Water Pollution Control Manual <http://dnr.metrokc.gov/wlr/dss/spcm.htm>

Mobile Cleaners Pilot Program: Final Report. 1997. Bay Area Stormwater Management Agencies Association (BASMAA). <http://www.basmaa.org/>

Pollution from Surface Cleaning Folder. 1996. Bay Area Stormwater Management Agencies Association (BASMAA). <http://www.basmaa.org/>

Santa Clara Valley Urban Runoff Pollution Prevention Program <http://www.scvurppp.org>

The Storm Water Managers Resource Center <http://www.stormwatercenter.net/>

# Parking/Storage Area Maintenance SC-43



## Description

Parking lots and storage areas can contribute a number of substances, such as trash, suspended solids, hydrocarbons, oil and grease, and heavy metals that can enter receiving waters through stormwater runoff or non-stormwater discharges. The protocols in this fact sheet are intended to prevent or reduce the discharge of pollutants from parking/storage areas and include using good housekeeping practices, following appropriate cleaning BMPs, and training employees.

## Approach

The goal of this program is to ensure stormwater pollution prevention practices are considered when conducting activities on or around parking areas and storage areas to reduce potential for pollutant discharge to receiving waters. Successful implementation depends on effective training of employees on applicable BMPs and general pollution prevention strategies and objectives.

## Pollution Prevention

- Encourage alternative designs and maintenance strategies for impervious parking lots. (See New Development and Redevelopment BMP Handbook)
- Keep accurate maintenance logs to evaluate BMP implementation.

## Objectives

- Cover
- Contain
- Educate
- Reduce/Minimize
- Product Substitution

## Targeted Constituents

Sediment	✓
Nutrients	
Trash	✓
Metals	✓
Bacteria	
Oil and Grease	✓
Organics	✓



# **SC-43 Parking/Storage Area Maintenance**

## ***Suggested Protocols***

### *General*

- Keep the parking and storage areas clean and orderly. Remove debris in a timely fashion.
- Allow sheet runoff to flow into biofilters (vegetated strip and swale) and/or infiltration devices.
- Utilize sand filters or oleophilic collectors for oily waste in low quantities.
- Arrange rooftop drains to prevent drainage directly onto paved surfaces.
- Design lot to include semi-permeable hardscape.
- Discharge soapy water remaining in mop or wash buckets to the sanitary sewer through a sink, toilet, clean-out, or wash area with drain.

### *Controlling Litter*

- Post “No Littering” signs and enforce anti-litter laws.
- Provide an adequate number of litter receptacles.
- Clean out and cover litter receptacles frequently to prevent spillage.
- Provide trash receptacles in parking lots to discourage litter.
- Routinely sweep, shovel, and dispose of litter in the trash.

### *Surface Cleaning*

- Use dry cleaning methods (e.g., sweeping, vacuuming) to prevent the discharge of pollutants into the stormwater conveyance system if possible.
- Establish frequency of public parking lot sweeping based on usage and field observations of waste accumulation.
- Sweep all parking lots at least once before the onset of the wet season.
- Follow the procedures below if water is used to clean surfaces:
  - Block the storm drain or contain runoff.
  - Collect and pump wash water to the sanitary sewer or discharge to a pervious surface. Do not allow wash water to enter storm drains.
  - Dispose of parking lot sweeping debris and dirt at a landfill.
- Follow the procedures below when cleaning heavy oily deposits:
  - Clean oily spots with absorbent materials.
  - Use a screen or filter fabric over inlet, then wash surfaces.

# **Parking/Storage Area Maintenance SC-43**

- Do not allow discharges to the storm drain.
- Vacuum/pump discharges to a tank or discharge to sanitary sewer.
- Appropriately dispose of spilled materials and absorbents.

## ***Surface Repair***

- Preheat, transfer or load hot bituminous material away from storm drain inlets.
- Apply concrete, asphalt, and seal coat during dry weather to prevent contamination from contacting stormwater runoff.
- Cover and seal nearby storm drain inlets where applicable (with waterproof material or mesh) and manholes before applying seal coat, slurry seal, etc. Leave covers in place until job is complete and all water from emulsified oil sealants has drained or evaporated. Clean any debris from these covered manholes and drains for proper disposal.
- Use only as much water as necessary for dust control, to avoid runoff.
- Catch drips from paving equipment that is not in use with pans or absorbent material placed under the machines. Dispose of collected material and absorbents properly.

## ***Inspection***

- Have designated personnel conduct inspections of parking facilities and stormwater conveyance systems associated with parking facilities on a regular basis.
- Inspect cleaning equipment/sweepers for leaks on a regular basis.

## ***Training***

- Provide regular training to field employees and/or contractors regarding cleaning of paved areas and proper operation of equipment.
- Train employees and contractors in proper techniques for spill containment and cleanup.

## ***Spill Response and Prevention***

- Keep your Spill Prevention Control and Countermeasure (SPCC) Plan up-to-date.
- Place a stockpile of spill cleanup materials where it will be readily accessible or at a central location.
- Clean up fluid spills immediately with absorbent rags or material.
- Dispose of spilled material and absorbents properly.

## ***Other Considerations***

Limitations related to sweeping activities at large parking facilities may include high equipment costs, the need for sweeper operator training, and the inability of current sweeper technology to remove oil and grease.

# **SC-43 Parking/Storage Area Maintenance**

## **Requirements**

### ***Costs***

Cleaning/sweeping costs can be quite large. Construction and maintenance of stormwater structural controls can be quite expensive as well.

### ***Maintenance***

- Sweep parking lot regularly to minimize cleaning with water.
- Clean out oil/water/sand separators regularly, especially after heavy storms.
- Clean parking facilities regularly to prevent accumulated wastes and pollutants from being discharged into conveyance systems during rainy conditions.

## **Supplemental Information**

### ***Further Detail of the BMP***

#### ***Surface Repair***

Apply concrete, asphalt, and seal coat during dry weather to prevent contamination from contacting stormwater runoff. Where applicable, cover and seal nearby storm drain inlets (with waterproof material or mesh) and manholes before applying seal coat, slurry seal, etc. Leave covers in place until job is complete and all water from emulsified oil sealants has drained or evaporated. Clean any debris from these covered manholes and drains for proper disposal. Only use only as much water as is necessary for dust control to avoid runoff.

## **References and Resources**

California's Nonpoint Source Program Plan <http://www.swrcb.ca.gov/nps/index.html>

Clark County Storm Water Pollution Control Manual  
<http://www.co.clark.wa.us/pubworks/bmpman.pdf>

King County Storm Water Pollution Control Manual <http://dnr.metrokc.gov/wlr/dss/spcm.htm>

Pollution from Surface Cleaning Folder. 1996. Bay Area Stormwater Management Agencies Association (BASMAA). <http://www.basmaa.org/>

Oregon Association of Clean Water Agencies. Oregon Municipal Stormwater Toolbox for Maintenance Practices. June 1998.

Santa Clara Valley Urban Runoff Pollution Prevention Program <http://www.scvurppp.org>

The Storm Water Managers Resource Center <http://www.stormwatercenter.net/>



## Objectives

- Cover
- Contain
- Educate
- Reduce/Minimize

## Description

As a consequence of its function, the stormwater conveyance system collects and transports urban runoff and stormwater that may contain certain pollutants. The protocols in this fact sheet are intended to reduce pollutants reaching receiving waters through proper conveyance system operation and maintenance.

## Approach

### *Pollution Prevention*

Maintain catch basins, stormwater inlets, and other stormwater conveyance structures on a regular basis to remove pollutants, reduce high pollutant concentrations during the first flush of storms, prevent clogging of the downstream conveyance system, restore catch basins' sediment trapping capacity, and ensure the system functions properly hydraulically to avoid flooding.

### *Suggested Protocols*

#### *Catch Basins/Inlet Structures*

- Staff should regularly inspect facilities to ensure compliance with the following:
  - Immediate repair of any deterioration threatening structural integrity.
  - Cleaning before the sump is 40% full. Catch basins should be cleaned as frequently as needed to meet this standard.
  - Stenciling of catch basins and inlets (see SC34 Waste Handling and Disposal).

## Targeted Constituents

Sediment	✓
Nutrients	
Trash	✓
Metals	
Bacteria	✓
Oil and Grease	
Organics	



- Clean catch basins, storm drain inlets, and other conveyance structures before the wet season to remove sediments and debris accumulated during the summer.
- Conduct inspections more frequently during the wet season for problem areas where sediment or trash accumulates more often. Clean and repair as needed.
- Keep accurate logs of the number of catch basins cleaned.
- Store wastes collected from cleaning activities of the drainage system in appropriate containers or temporary storage sites in a manner that prevents discharge to the storm drain.
- Dewater the wastes if necessary with outflow into the sanitary sewer if permitted. Water should be treated with an appropriate filtering device prior to discharge to the sanitary sewer. If discharge to the sanitary sewer is not allowed, water should be pumped or vacuumed to a tank and properly disposed. Do not dewater near a storm drain or stream.

#### *Storm Drain Conveyance System*

- Locate reaches of storm drain with deposit problems and develop a flushing schedule that keeps the pipe clear of excessive buildup.
- Collect and pump flushed effluent to the sanitary sewer for treatment whenever possible.

#### *Pump Stations*

- Clean all storm drain pump stations prior to the wet season to remove silt and trash.
- Do not allow discharge to reach the storm drain system when cleaning a storm drain pump station or other facility.
- Conduct routine maintenance at each pump station.
- Inspect, clean, and repair as necessary all outlet structures prior to the wet season.

#### *Open Channel*

- Modify storm channel characteristics to improve channel hydraulics, increase pollutant removals, and enhance channel/creek aesthetic and habitat value.
- Conduct channel modification/improvement in accordance with existing laws. Any person, government agency, or public utility proposing an activity that will change the natural (emphasis added) state of any river, stream, or lake in California, must enter into a Stream or Lake Alteration Agreement with the Department of Fish and Game. The developer-applicant should also contact local governments (city, county, special districts), other state agencies (SWRCB, RWQCB, Department of Forestry, Department of Water Resources), and Federal Corps of Engineers and USFWS.

#### *Illicit Connections and Discharges*

- Look for evidence of illegal discharges or illicit connections during routine maintenance of conveyance system and drainage structures:
  - Is there evidence of spills such as paints, discoloring, etc?

- Are there any odors associated with the drainage system?
- Record locations of apparent illegal discharges/illicit connections?
- Track flows back to potential dischargers and conduct aboveground inspections. This can be done through visual inspection of upgradient manholes or alternate techniques including zinc chloride smoke testing, fluorometric dye testing, physical inspection testing, or television camera inspection.
- Eliminate the discharge once the origin of flow is established.
- Stencil or demarcate storm drains, where applicable, to prevent illegal disposal of pollutants. Storm drain inlets should have messages such as “Dump No Waste Drains to Stream” stenciled next to them to warn against ignorant or intentional dumping of pollutants into the storm drainage system.
- Refer to fact sheet SC-10 Non-Stormwater Discharges.

### *Illegal Dumping*

- Inspect and clean up hot spots and other storm drainage areas regularly where illegal dumping and disposal occurs.
- Establish a system for tracking incidents. The system should be designed to identify the following:
  - Illegal dumping hot spots
  - Types and quantities (in some cases) of wastes
  - Patterns in time of occurrence (time of day/night, month, or year)
  - Mode of dumping (abandoned containers, “midnight dumping” from moving vehicles, direct dumping of materials, accidents/spills)
  - Responsible parties
- Post “No Dumping” signs in problem areas with a phone number for reporting dumping and disposal. Signs should also indicate fines and penalties for illegal dumping.
- Refer to fact sheet SC-10 Non-Stormwater Discharges.

### *Training*

- Train crews in proper maintenance activities, including record keeping and disposal.
- Allow only properly trained individuals to handle hazardous materials/wastes.
- Have staff involved in detection and removal of illicit connections trained in the following:
  - OSHA-required Health and Safety Training (29 CFR 1910.120) plus annual refresher training (as needed).

# SC-44      Drainage System Maintenance

---

- OSHA Confined Space Entry training (Cal-OSHA Confined Space, Title 8 and Federal OSHA 29 CFR 1910.146).
- Procedural training (field screening, sampling, smoke/dye testing, TV inspection).

## ***Spill Response and Prevention***

- Investigate all reports of spills, leaks, and/or illegal dumping promptly.
- Clean up all spills and leaks using “dry” methods (with absorbent materials and/or rags) or dig up, remove, and properly dispose of contaminated soil.
- Refer to fact sheet SC-11 Spill Prevention, Control, and Cleanup.

## ***Other Considerations (Limitations and Regulations)***

- Clean-up activities may create a slight disturbance for local aquatic species. Access to items and material on private property may be limited. Trade-offs may exist between channel hydraulics and water quality/riparian habitat. If storm channels or basins are recognized as wetlands, many activities, including maintenance, may be subject to regulation and permitting.
- Storm drain flushing is most effective in small diameter pipes (36-inch diameter pipe or less, depending on water supply and sediment collection capacity). Other considerations associated with storm drain flushing may include the availability of a water source, finding a downstream area to collect sediments, liquid/sediment disposal, and prohibition against disposal of flushed effluent to sanitary sewer in some areas.
- Regulations may include adoption of substantial penalties for illegal dumping and disposal.
- Local municipal codes may include sections prohibiting discharge of soil, debris, refuse, hazardous wastes, and other pollutants into the storm drain system.

## **Requirements**

### ***Costs***

- An aggressive catch basin cleaning program could require a significant capital and O&M budget.
- The elimination of illegal dumping is dependent on the availability, convenience, and cost of alternative means of disposal. The primary cost is for staff time. Cost depends on how aggressively a program is implemented. Other cost considerations for an illegal dumping program include:
  - Purchase and installation of signs.
  - Rental of vehicle(s) to haul illegally-disposed items and material to landfills.
  - Rental of heavy equipment to remove larger items (e.g., car bodies) from channels.
  - Purchase of landfill space to dispose of illegally-dumped items and material.

- Methods used for illicit connection detection (smoke testing, dye testing, visual inspection, and flow monitoring) can be costly and time-consuming. Site-specific factors, such as the level of impervious area, the density and ages of buildings, and type of land use will determine the level of investigation necessary.

## ***Maintenance***

- Two-person teams may be required to clean catch basins with vacuum trucks.
- Teams of at least two people plus administrative personnel are required to identify illicit discharges, depending on the complexity of the storm sewer system.
- Arrangements must be made for proper disposal of collected wastes.
- Technical staff are required to detect and investigate illegal dumping violations.

## **Supplemental Information**

### ***Further Detail of the BMP***

#### ***Storm Drain Flushing***

Flushing is a common maintenance activity used to improve pipe hydraulics and to remove pollutants in storm drainage systems. Flushing may be designed to hydraulically convey accumulated material to strategic locations, such as an open channel, another point where flushing will be initiated, or the sanitary sewer and the treatment facilities, thus preventing resuspension and overflow of a portion of the solids during storm events. Flushing prevents “plug flow” discharges of concentrated pollutant loadings and sediments. Deposits can hinder the designed conveyance capacity of the storm drain system and potentially cause backwater conditions in severe cases of clogging.

Storm drain flushing usually takes place along segments of pipe with grades that are too flat to maintain adequate velocity to keep particles in suspension. An upstream manhole is selected to place an inflatable device that temporarily plugs the pipe. Further upstream, water is pumped into the line to create a flushing wave. When the upstream reach of pipe is sufficiently full to cause a flushing wave, the inflated device is rapidly deflated with the assistance of a vacuum pump, thereby releasing the backed up water and resulting in the cleaning of the storm drain segment.

To further reduce impacts of stormwater pollution, a second inflatable device placed well downstream may be used to recollect the water after the force of the flushing wave has dissipated. A pump may then be used to transfer the water and accumulated material to the sanitary sewer for treatment. In some cases, an interceptor structure may be more practical or required to recollect the flushed waters.

It has been found that cleansing efficiency of periodic flush waves is dependent upon flush volume, flush discharge rate, sewer slope, sewer length, sewer flow rate, sewer diameter, and population density. As a rule of thumb, the length of line to be flushed should not exceed 700 feet. At this maximum recommended length, the percent removal efficiency ranges between 65-75% for organics and 55-65% for dry weather grit/inorganic material. The percent removal efficiency drops rapidly beyond that. Water is commonly supplied by a water truck, but fire hydrants can also supply water. To make the best use of water, it is recommended that reclaimed water be used or that fire hydrant line flushing coincide with storm sewer flushing.

# **SC-44                      Drainage System Maintenance**

---

## **References and Resources**

California's Nonpoint Source Program Plan <http://www.swrcb.ca.gov/nps/index.html>

Clark County Storm Water Pollution Control Manual  
<http://www.co.clark.wa.us/pubworks/bmpman.pdf>

Ferguson, B.K. 1991. Urban Stream Reclamation, p. 324-322, Journal of Soil and Water Conservation.

King County Storm Water Pollution Control Manual <http://dnr.metrokc.gov/wlr/dss/spcm.htm>

Oregon Association of Clean Water Agencies. Oregon Municipal Stormwater Toolbox for Maintenance Practices. June 1998.

Santa Clara Valley Urban Runoff Pollution Prevention Program <http://www.scvurppp.org>

The Storm Water Managers Resource Center <http://www.stormwatercenter.net>

United States Environmental Protection Agency (USEPA). 2002. Pollution Prevention/Good Housekeeping for Municipal Operations Storm Drain System Cleaning. On line:  
[http://www.epa.gov/npdes/menuofbmps/poll\\_16.htm](http://www.epa.gov/npdes/menuofbmps/poll_16.htm)

# Site Design & Landscape Planning SD-10



## Design Objectives

- Maximize Infiltration
- Provide Retention
- Slow Runoff
- Minimize Impervious Land Coverage
- Prohibit Dumping of Improper Materials
- Contain Pollutants
- Collect and Convey

## Description

Each project site possesses unique topographic, hydrologic, and vegetative features, some of which are more suitable for development than others. Integrating and incorporating appropriate landscape planning methodologies into the project design is the most effective action that can be done to minimize surface and groundwater contamination from stormwater.

## Approach

Landscape planning should couple consideration of land suitability for urban uses with consideration of community goals and projected growth. Project plan designs should conserve natural areas to the extent possible, maximize natural water storage and infiltration opportunities, and protect slopes and channels.

## Suitable Applications

Appropriate applications include residential, commercial and industrial areas planned for development or redevelopment.

## Design Considerations

Design requirements for site design and landscapes planning should conform to applicable standards and specifications of agencies with jurisdiction and be consistent with applicable General Plan and Local Area Plan policies.



# **SD-10 Site Design & Landscape Planning**

## ***Designing New Installations***

Begin the development of a plan for the landscape unit with attention to the following general principles:

- Formulate the plan on the basis of clearly articulated community goals. Carefully identify conflicts and choices between retaining and protecting desired resources and community growth.
- Map and assess land suitability for urban uses. Include the following landscape features in the assessment: wooded land, open unwooded land, steep slopes, erosion-prone soils, foundation suitability, soil suitability for waste disposal, aquifers, aquifer recharge areas, wetlands, floodplains, surface waters, agricultural lands, and various categories of urban land use. When appropriate, the assessment can highlight outstanding local or regional resources that the community determines should be protected (e.g., a scenic area, recreational area, threatened species habitat, farmland, fish run). Mapping and assessment should recognize not only these resources but also additional areas needed for their sustenance.

Project plan designs should conserve natural areas to the extent possible, maximize natural water storage and infiltration opportunities, and protect slopes and channels.

## ***Conserve Natural Areas during Landscape Planning***

If applicable, the following items are required and must be implemented in the site layout during the subdivision design and approval process, consistent with applicable General Plan and Local Area Plan policies:

- Cluster development on least-sensitive portions of a site while leaving the remaining land in a natural undisturbed condition.
- Limit clearing and grading of native vegetation at a site to the minimum amount needed to build lots, allow access, and provide fire protection.
- Maximize trees and other vegetation at each site by planting additional vegetation, clustering tree areas, and promoting the use of native and/or drought tolerant plants.
- Promote natural vegetation by using parking lot islands and other landscaped areas.
- Preserve riparian areas and wetlands.

## ***Maximize Natural Water Storage and Infiltration Opportunities Within the Landscape Unit***

- Promote the conservation of forest cover. Building on land that is already deforested affects basin hydrology to a lesser extent than converting forested land. Loss of forest cover reduces interception storage, detention in the organic forest floor layer, and water losses by evapotranspiration, resulting in large peak runoff increases and either their negative effects or the expense of countering them with structural solutions.
- Maintain natural storage reservoirs and drainage corridors, including depressions, areas of permeable soils, swales, and intermittent streams. Develop and implement policies and

# Site Design & Landscape Planning SD-10

---

regulations to discourage the clearing, filling, and channelization of these features. Utilize them in drainage networks in preference to pipes, culverts, and engineered ditches.

- Evaluating infiltration opportunities by referring to the stormwater management manual for the jurisdiction and pay particular attention to the selection criteria for avoiding groundwater contamination, poor soils, and hydrogeological conditions that cause these facilities to fail. If necessary, locate developments with large amounts of impervious surfaces or a potential to produce relatively contaminated runoff away from groundwater recharge areas.

## *Protection of Slopes and Channels during Landscape Design*

- Convey runoff safely from the tops of slopes.
- Avoid disturbing steep or unstable slopes.
- Avoid disturbing natural channels.
- Stabilize disturbed slopes as quickly as possible.
- Vegetate slopes with native or drought tolerant vegetation.
- Control and treat flows in landscaping and/or other controls prior to reaching existing natural drainage systems.
- Stabilize temporary and permanent channel crossings as quickly as possible, and ensure that increases in run-off velocity and frequency caused by the project do not erode the channel.
- Install energy dissipaters, such as riprap, at the outlets of new storm drains, culverts, conduits, or channels that enter unlined channels in accordance with applicable specifications to minimize erosion. Energy dissipaters shall be installed in such a way as to minimize impacts to receiving waters.
- Line on-site conveyance channels where appropriate, to reduce erosion caused by increased flow velocity due to increases in tributary impervious area. The first choice for linings should be grass or some other vegetative surface, since these materials not only reduce runoff velocities, but also provide water quality benefits from filtration and infiltration. If velocities in the channel are high enough to erode grass or other vegetative linings, riprap, concrete, soil cement, or geo-grid stabilization are other alternatives.
- Consider other design principles that are comparable and equally effective.

## ***Redeveloping Existing Installations***

Various jurisdictional stormwater management and mitigation plans (SUSMP, WQMP, etc.) define “redevelopment” in terms of amounts of additional impervious area, increases in gross floor area and/or exterior construction, and land disturbing activities with structural or impervious surfaces. The definition of “redevelopment” must be consulted to determine whether or not the requirements for new development apply to areas intended for redevelopment. If the definition applies, the steps outlined under “designing new installations” above should be followed.

## **SD-10 Site Design & Landscape Planning**

Redevelopment may present significant opportunity to add features which had not previously been implemented. Examples include incorporation of depressions, areas of permeable soils, and swales in newly redeveloped areas. While some site constraints may exist due to the status of already existing infrastructure, opportunities should not be missed to maximize infiltration, slow runoff, reduce impervious areas, disconnect directly connected impervious areas.

### **Other Resources**

A Manual for the Standard Urban Stormwater Mitigation Plan (SUSMP), Los Angeles County Department of Public Works, May 2002.

Stormwater Management Manual for Western Washington, Washington State Department of Ecology, August 2001.

Model Standard Urban Storm Water Mitigation Plan (SUSMP) for San Diego County, Port of San Diego, and Cities in San Diego County, February 14, 2002.

Model Water Quality Management Plan (WQMP) for County of Orange, Orange County Flood Control District, and the Incorporated Cities of Orange County, Draft February 2003.

Ventura Countywide Technical Guidance Manual for Stormwater Quality Control Measures, July 2002.



Rain Garden

## Design Objectives

- Maximize Infiltration
- Provide Retention
- Slow Runoff
- Minimize Impervious Land Coverage
- Prohibit Dumping of Improper Materials
- Contain Pollutants
- Collect and Convey

## Description

Various roof runoff controls are available to address stormwater that drains off rooftops. The objective is to reduce the total volume and rate of runoff from individual lots, and retain the pollutants on site that may be picked up from roofing materials and atmospheric deposition. Roof runoff controls consist of directing the roof runoff away from paved areas and mitigating flow to the storm drain system through one of several general approaches: cisterns or rain barrels; dry wells or infiltration trenches; pop-up emitters, and foundation planting. The first three approaches require the roof runoff to be contained in a gutter and downspout system. Foundation planting provides a vegetated strip under the drip line of the roof.

## Approach

Design of individual lots for single-family homes as well as lots for higher density residential and commercial structures should consider site design provisions for containing and infiltrating roof runoff or directing roof runoff to vegetative swales or buffer areas. Retained water can be reused for watering gardens, lawns, and trees. Benefits to the environment include reduced demand for potable water used for irrigation, improved stormwater quality, increased groundwater recharge, decreased runoff volume and peak flows, and decreased flooding potential.

## Suitable Applications

Appropriate applications include residential, commercial and industrial areas planned for development or redevelopment.

## Design Considerations

### *Designing New Installations*

#### *Cisterns or Rain Barrels*

One method of addressing roof runoff is to direct roof downspouts to cisterns or rain barrels. A cistern is an above ground storage vessel with either a manually operated valve or a permanently open outlet. Roof runoff is temporarily stored and then released for irrigation or infiltration between storms. The number of rain



barrels needed is a function of the rooftop area. Some low impact developers recommend that every house have at least 2 rain barrels, with a minimum storage capacity of 1000 liters. Roof barrels serve several purposes including mitigating the first flush from the roof which has a high volume, amount of contaminants, and thermal load. Several types of rain barrels are commercially available. Consideration must be given to selecting rain barrels that are vector proof and childproof. In addition, some barrels are designed with a bypass valve that filters out grit and other contaminants and routes overflow to a soak-away pit or rain garden.

If the cistern has an operable valve, the valve can be closed to store stormwater for irrigation or infiltration between storms. This system requires continual monitoring by the resident or grounds crews, but provides greater flexibility in water storage and metering. If a cistern is provided with an operable valve and water is stored inside for long periods, the cistern must be covered to prevent mosquitoes from breeding.

A cistern system with a permanently open outlet can also provide for metering stormwater runoff. If the cistern outlet is significantly smaller than the size of the downspout inlet (say ¼ to ½ inch diameter), runoff will build up inside the cistern during storms, and will empty out slowly after peak intensities subside. This is a feasible way to mitigate the peak flow increases caused by rooftop impervious land coverage, especially for the frequent, small storms.

#### *Dry wells and Infiltration Trenches*

Roof downspouts can be directed to dry wells or infiltration trenches. A dry well is constructed by excavating a hole in the ground and filling it with an open graded aggregate, and allowing the water to fill the dry well and infiltrate after the storm event. An underground connection from the downspout conveys water into the dry well, allowing it to be stored in the voids. To minimize sedimentation from lateral soil movement, the sides and top of the stone storage matrix can be wrapped in a permeable filter fabric, though the bottom may remain open. A perforated observation pipe can be inserted vertically into the dry well to allow for inspection and maintenance.

In practice, dry wells receiving runoff from single roof downspouts have been successful over long periods because they contain very little sediment. They must be sized according to the amount of rooftop runoff received, but are typically 4 to 5 feet square, and 2 to 3 feet deep, with a minimum of 1-foot soil cover over the top (maximum depth of 10 feet).

To protect the foundation, dry wells must be set away from the building at least 10 feet. They must be installed in solids that accommodate infiltration. In poorly drained soils, dry wells have very limited feasibility.

Infiltration trenches function in a similar manner and would be particularly effective for larger roof areas. An infiltration trench is a long, narrow, rock-filled trench with no outlet that receives stormwater runoff. These are described under Treatment Controls.

#### *Pop-up Drainage Emitter*

Roof downspouts can be directed to an underground pipe that daylight some distance from the building foundation, releasing the roof runoff through a pop-up emitter. Similar to a pop-up irrigation head, the emitter only opens when there is flow from the roof. The emitter remains flush to the ground during dry periods, for ease of lawn or landscape maintenance.

## *Foundation Planting*

Landscape planting can be provided around the base to allow increased opportunities for stormwater infiltration and protect the soil from erosion caused by concentrated sheet flow coming off the roof. Foundation plantings can reduce the physical impact of water on the soil and provide a subsurface matrix of roots that encourage infiltration. These plantings must be sturdy enough to tolerate the heavy runoff sheet flows, and periodic soil saturation.

## ***Redeveloping Existing Installations***

Various jurisdictional stormwater management and mitigation plans (SUSMP, WQMP, etc.) define “redevelopment” in terms of amounts of additional impervious area, increases in gross floor area and/or exterior construction, and land disturbing activities with structural or impervious surfaces. The definition of “redevelopment” must be consulted to determine whether or not the requirements for new development apply to areas intended for redevelopment. If the definition applies, the steps outlined under “designing new installations” above should be followed.

## **Supplemental Information**

### ***Examples***

- City of Ottawa’s Water Links Surface –Water Quality Protection Program
- City of Toronto Downspout Disconnection Program
- City of Boston, MA, Rain Barrel Demonstration Program

### **Other Resources**

Hager, Marty Catherine, Stormwater, “Low-Impact Development”, January/February 2003.  
[www.stormh2o.com](http://www.stormh2o.com)

Low Impact Urban Design Tools, Low Impact Development Design Center, Beltsville, MD.  
[www.lid-stormwater.net](http://www.lid-stormwater.net)

Start at the Source, Bay Area Stormwater Management Agencies Association, 1999 Edition

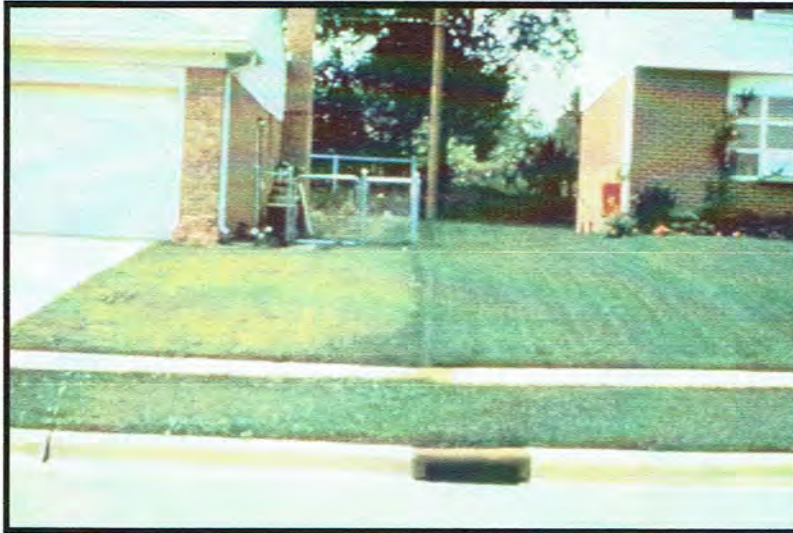

## Design Objectives

- Maximize Infiltration
- Provide Retention
- Slow Runoff
- Minimize Impervious Land Coverage
- Prohibit Dumping of Improper Materials
- Contain Pollutants
- Collect and Convey

## Description

Irrigation water provided to landscaped areas may result in excess irrigation water being conveyed into stormwater drainage systems.

## Approach

Project plan designs for development and redevelopment should include application methods of irrigation water that minimize runoff of excess irrigation water into the stormwater conveyance system.

## Suitable Applications

Appropriate applications include residential, commercial and industrial areas planned for development or redevelopment. (Detached residential single-family homes are typically excluded from this requirement.)

## Design Considerations

### *Designing New Installations*

The following methods to reduce excessive irrigation runoff should be considered, and incorporated and implemented where determined applicable and feasible by the Permittee:

- Employ rain-triggered shutoff devices to prevent irrigation after precipitation.
- Design irrigation systems to each landscape area's specific water requirements.
- Include design featuring flow reducers or shutoff valves triggered by a pressure drop to control water loss in the event of broken sprinkler heads or lines.
- Implement landscape plans consistent with County or City water conservation resolutions, which may include provision of water sensors, programmable irrigation times (for short cycles), etc.



- Design timing and application methods of irrigation water to minimize the runoff of excess irrigation water into the storm water drainage system.
- Group plants with similar water requirements in order to reduce excess irrigation runoff and promote surface filtration. Choose plants with low irrigation requirements (for example, native or drought tolerant species). Consider design features such as:
  - Using mulches (such as wood chips or bar) in planter areas without ground cover to minimize sediment in runoff
  - Installing appropriate plant materials for the location, in accordance with amount of sunlight and climate, and use native plant materials where possible and/or as recommended by the landscape architect
  - Leaving a vegetative barrier along the property boundary and interior watercourses, to act as a pollutant filter, where appropriate and feasible
  - Choosing plants that minimize or eliminate the use of fertilizer or pesticides to sustain growth
- Employ other comparable, equally effective methods to reduce irrigation water runoff.

***Redeveloping Existing Installations***

Various jurisdictional stormwater management and mitigation plans (SUSMP, WQMP, etc.) define “redevelopment” in terms of amounts of additional impervious area, increases in gross floor area and/or exterior construction, and land disturbing activities with structural or impervious surfaces. The definition of “redevelopment” must be consulted to determine whether or not the requirements for new development apply to areas intended for redevelopment. If the definition applies, the steps outlined under “designing new installations” above should be followed.

**Other Resources**

A Manual for the Standard Urban Stormwater Mitigation Plan (SUSMP), Los Angeles County Department of Public Works, May 2002.

Model Standard Urban Storm Water Mitigation Plan (SUSMP) for San Diego County, Port of San Diego, and Cities in San Diego County, February 14, 2002.

Model Water Quality Management Plan (WQMP) for County of Orange, Orange County Flood Control District, and the Incorporated Cities of Orange County, Draft February 2003.

Ventura Countywide Technical Guidance Manual for Stormwater Quality Control Measures, July 2002.

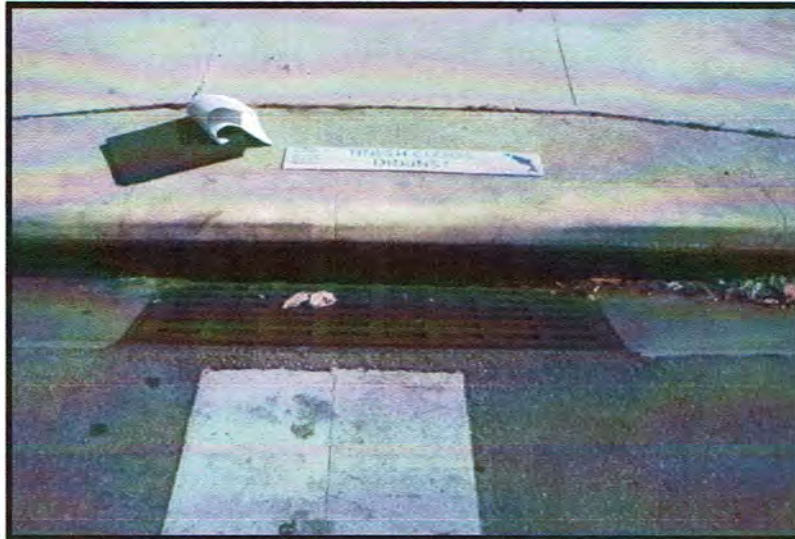

## Design Objectives

- Maximize Infiltration
- Provide Retention
- Slow Runoff
- Minimize Impervious Land Coverage
- Prohibit Dumping of Improper Materials
- Contain Pollutants
- Collect and Convey

## Description

Waste materials dumped into storm drain inlets can have severe impacts on receiving and ground waters. Posting notices regarding discharge prohibitions at storm drain inlets can prevent waste dumping. Storm drain signs and stencils are highly visible source controls that are typically placed directly adjacent to storm drain inlets.

## Approach

The stencil or affixed sign contains a brief statement that prohibits dumping of improper materials into the urban runoff conveyance system. Storm drain messages have become a popular method of alerting the public about the effects of and the prohibitions against waste disposal.

## Suitable Applications

Stencils and signs alert the public to the destination of pollutants discharged to the storm drain. Signs are appropriate in residential, commercial, and industrial areas, as well as any other area where contributions or dumping to storm drains is likely.

## Design Considerations

Storm drain message markers or placards are recommended at all storm drain inlets within the boundary of a development project. The marker should be placed in clear sight facing toward anyone approaching the inlet from either side. All storm drain inlet locations should be identified on the development site map.

## Designing New Installations

The following methods should be considered for inclusion in the project design and show on project plans:

- Provide stenciling or labeling of all storm drain inlets and catch basins, constructed or modified, within the project area with prohibitive language. Examples include "NO DUMPING



- DRAINS TO OCEAN” and/or other graphical icons to discourage illegal dumping.
- Post signs with prohibitive language and/or graphical icons, which prohibit illegal dumping at public access points along channels and creeks within the project area.

Note - Some local agencies have approved specific signage and/or storm drain message placards for use. Consult local agency stormwater staff to determine specific requirements for placard types and methods of application.

### ***Redeveloping Existing Installations***

Various jurisdictional stormwater management and mitigation plans (SUSMP, WQMP, etc.) define “redevelopment” in terms of amounts of additional impervious area, increases in gross floor area and/or exterior construction, and land disturbing activities with structural or impervious surfaces. If the project meets the definition of “redevelopment”, then the requirements stated under “designing new installations” above should be included in all project design plans.

### **Additional Information**

#### ***Maintenance Considerations***

- Legibility of markers and signs should be maintained. If required by the agency with jurisdiction over the project, the owner/operator or homeowner’s association should enter into a maintenance agreement with the agency or record a deed restriction upon the property title to maintain the legibility of placards or signs.

#### ***Placement***

- Signage on top of curbs tends to weather and fade.
- Signage on face of curbs tends to be worn by contact with vehicle tires and sweeper brooms.

### **Supplemental Information**

#### ***Examples***

- Most MS4 programs have storm drain signage programs. Some MS4 programs will provide stencils, or arrange for volunteers to stencil storm drains as part of their outreach program.

### **Other Resources**

A Manual for the Standard Urban Stormwater Mitigation Plan (SUSMP), Los Angeles County Department of Public Works, May 2002.

Model Standard Urban Storm Water Mitigation Plan (SUSMP) for San Diego County, Port of San Diego, and Cities in San Diego County, February 14, 2002.

Model Water Quality Management Plan (WQMP) for County of Orange, Orange County Flood Control District, and the Incorporated Cities of Orange County, Draft February 2003.

Ventura Countywide Technical Guidance Manual for Stormwater Quality Control Measures, July 2002.



Photo Credit: Geoff Brosseau

## Design Objectives

- Maximize Infiltration
- Provide Retention
- Slow Runoff
- Minimize Impervious Land Coverage
- Prohibit Dumping of Improper Materials
- Contain Pollutants
- Collect and Convey

## Description

Fueling areas have the potential to contribute oil and grease, solvents, car battery acid, coolant and gasoline to the stormwater conveyance system. Spills at vehicle and equipment fueling areas can be a significant source of pollution because fuels contain toxic materials and heavy metals that are not easily removed by stormwater treatment devices.

## Approach

Project plans must be developed for cleaning near fuel dispensers, emergency spill cleanup, containment, and leak prevention.

## Suitable Applications

Appropriate applications include commercial, industrial, and any other areas planned to have fuel dispensing equipment, including retail gasoline outlets, automotive repair shops, and major non-retail dispensing areas.

## Design Considerations

Design requirements for fueling areas are governed by Building and Fire Codes and by current local agency ordinances and zoning requirements. Design requirements described in this fact sheet are meant to enhance and be consistent with these code and ordinance requirements.

## *Designing New Installations*

### *Covering*



Fuel dispensing areas should provide an overhanging roof structure or canopy. The cover's minimum dimensions must be equal to or greater than the area within the grade break. The cover must not drain onto the fuel dispensing area and the downspouts must be routed to prevent drainage across the fueling area. The fueling area should drain to the project's treatment control BMP(s) prior to discharging to the stormwater conveyance system. Note - If fueling large equipment or vehicles that would prohibit the use of covers or roofs, the fueling island should be designed to sufficiently accommodate the larger vehicles and equipment and to prevent stormwater run-on and runoff. Grade to direct stormwater to a dead-end sump.

#### *Surfacing*

Fuel dispensing areas should be paved with Portland cement concrete (or equivalent smooth impervious surface). The use of asphalt concrete should be prohibited. Use asphalt sealant to protect asphalt paved areas surrounding the fueling area. This provision may be made to sites that have pre-existing asphalt surfaces.

The concrete fuel dispensing area should be extended a minimum of 6.5 ft from the corner of each fuel dispenser, or the length at which the hose and nozzle assembly may be operated plus 1 ft, whichever is less.

#### *Grading/Contouring*

Dispensing areas should have an appropriate slope to prevent ponding, and be separated from the rest of the site by a grade break that prevents run-on of urban runoff. (Slope is required to be 2 to 4% in some jurisdictions' stormwater management and mitigation plans.)

Fueling areas should be graded to drain toward a dead-end sump. Runoff from downspouts/roofs should be directed away from fueling areas. Do not locate storm drains in the immediate vicinity of the fueling area.

#### ***Redeveloping Existing Installations***

Various jurisdictional stormwater management and mitigation plans (SUSMP, WQMP, etc.) define "redevelopment" in terms of amounts of additional impervious area, increases in gross floor area and/or exterior construction, and land disturbing activities with structural or impervious surfaces. The definition of "redevelopment" must be consulted to determine whether or not the requirements for new development apply to areas intended for redevelopment. If the definition applies, the steps outlined under "designing new installations" above should be followed.

#### **Additional Information**

- In the case of an emergency, provide storm drain seals, such as isolation valves, drain plugs, or drain covers, to prevent spills or contaminated stormwater from entering the stormwater conveyance system.

#### **Other Resources**

A Manual for the Standard Urban Stormwater Mitigation Plan (SUSMP), Los Angeles County Department of Public Works, May 2002.

Model Standard Urban Storm Water Mitigation Plan (SUSMP) for San Diego County, Port of San Diego, and Cities in San Diego County, February 14, 2002.

Model Water Quality Management Plan (WQMP) for County of Orange, Orange County Flood Control District, and the Incorporated Cities of Orange County, Draft February 2003.

Ventura Countywide Technical Guidance Manual for Stormwater Quality Control Measures, July 2002.



## Design Objectives

- Maximize Infiltration
- Provide Retention
- Slow Runoff
- Minimize Impervious Land Coverage
- Prohibit Dumping of Improper Materials
- Contain Pollutants
- Collect and Convey

## Description

Several measures can be taken to prevent operations at maintenance bays and loading docks from contributing a variety of toxic compounds, oil and grease, heavy metals, nutrients, suspended solids, and other pollutants to the stormwater conveyance system.

## Approach

In designs for maintenance bays and loading docks, containment is encouraged. Preventative measures include overflow containment structures and dead-end sumps. However, in the case of loading docks from grocery stores and warehouse/distribution centers, engineered infiltration systems may be considered.

## Suitable Applications

Appropriate applications include commercial and industrial areas planned for development or redevelopment.

## Design Considerations

Design requirements for vehicle maintenance and repair are governed by Building and Fire Codes, and by current local agency ordinances, and zoning requirements. The design criteria described in this fact sheet are meant to enhance and be consistent with these code requirements.

## Designing New Installations

Designs of maintenance bays should consider the following:

- Repair/maintenance bays and vehicle parts with fluids should be indoors; or designed to preclude urban run-on and runoff.
- Repair/maintenance floor areas should be paved with Portland cement concrete (or equivalent smooth impervious surface).



- Repair/maintenance bays should be designed to capture all wash water leaks and spills. Provide impermeable berms, drop inlets, trench catch basins, or overflow containment structures around repair bays to prevent spilled materials and wash-down waters from entering the storm drain system. Connect drains to a sump for collection and disposal. Direct connection of the repair/maintenance bays to the storm drain system is prohibited. If required by local jurisdiction, obtain an Industrial Waste Discharge Permit.
- Other features may be comparable and equally effective.

The following designs of loading/unloading dock areas should be considered:

- Loading dock areas should be covered, or drainage should be designed to preclude urban run-on and runoff.
- Direct connections into storm drains from depressed loading docks (truck wells) are prohibited.
- Below-grade loading docks from grocery stores and warehouse/distribution centers of fresh food items should drain through water quality inlets, or to an engineered infiltration system, or an equally effective alternative. Pre-treatment may also be required.
- Other features may be comparable and equally effective.

#### ***Redeveloping Existing Installations***

Various jurisdictional stormwater management and mitigation plans (SUSMP, WQMP, etc.) define “redevelopment” in terms of amounts of additional impervious area, increases in gross floor area and/or exterior construction, and land disturbing activities with structural or impervious surfaces. The definition of “redevelopment” must be consulted to determine whether or not the requirements for new development apply to areas intended for redevelopment. If the definition applies, the steps outlined under “designing new installations” above should be followed.

#### **Additional Information**

Stormwater and non-stormwater will accumulate in containment areas and sumps with impervious surfaces. Contaminated accumulated water must be disposed of in accordance with applicable laws and cannot be discharged directly to the storm drain or sanitary sewer system without the appropriate permit.

#### **Other Resources**

A Manual for the Standard Urban Stormwater Mitigation Plan (SUSMP), Los Angeles County Department of Public Works, May 2002.

Model Standard Urban Storm Water Mitigation Plan (SUSMP) for San Diego County, Port of San Diego, and Cities in San Diego County, February 14, 2002.

Model Water Quality Management Plan (WQMP) for County of Orange, Orange County Flood Control District, and the Incorporated Cities of Orange County, Draft February 2003.

Ventura Countywide Technical Guidance Manual for Stormwater Quality Control Measures, July 2002.

## Description

Trash storage areas are areas where a trash receptacle (s) are located for use as a repository for solid wastes. Stormwater runoff from areas where trash is stored or disposed of can be polluted. In addition, loose trash and debris can be easily transported by water or wind into nearby storm drain inlets, channels, and/or creeks. Waste handling operations that may be sources of stormwater pollution include dumpsters, litter control, and waste piles.

## Approach

This fact sheet contains details on the specific measures required to prevent or reduce pollutants in stormwater runoff associated with trash storage and handling. Preventative measures including enclosures, containment structures, and impervious pavements to mitigate spills, should be used to reduce the likelihood of contamination.

## Suitable Applications

Appropriate applications include residential, commercial and industrial areas planned for development or redevelopment. (Detached residential single-family homes are typically excluded from this requirement.)

## Design Considerations

Design requirements for waste handling areas are governed by Building and Fire Codes, and by current local agency ordinances and zoning requirements. The design criteria described in this fact sheet are meant to enhance and be consistent with these code and ordinance requirements. Hazardous waste should be handled in accordance with legal requirements established in Title 22, California Code of Regulation.

Wastes from commercial and industrial sites are typically hauled by either public or commercial carriers that may have design or access requirements for waste storage areas. The design criteria in this fact sheet are recommendations and are not intended to be in conflict with requirements established by the waste hauler. The waste hauler should be contacted prior to the design of your site trash collection areas. Conflicts or issues should be discussed with the local agency.

## Designing New Installations

Trash storage areas should be designed to consider the following structural or treatment control BMPs:

- Design trash container areas so that drainage from adjoining roofs and pavement is diverted around the area(s) to avoid run-on. This might include berming or grading the waste handling area to prevent run-on of stormwater.
- Make sure trash container areas are screened or walled to prevent off-site transport of trash.

## Design Objectives

- Maximize Infiltration
- Provide Retention
- Slow Runoff
- Minimize Impervious Land Coverage
- Prohibit Dumping of Improper Materials
- Contain Pollutants
- Collect and Convey



- Use lined bins or dumpsters to reduce leaking of liquid waste.
- Provide roofs, awnings, or attached lids on all trash containers to minimize direct precipitation and prevent rainfall from entering containers.
- Pave trash storage areas with an impervious surface to mitigate spills.
- Do not locate storm drains in immediate vicinity of the trash storage area.
- Post signs on all dumpsters informing users that hazardous materials are not to be disposed of therein.

***Redeveloping Existing Installations***

Various jurisdictional stormwater management and mitigation plans (SUSMP, WQMP, etc.) define “redevelopment” in terms of amounts of additional impervious area, increases in gross floor area and/or exterior construction, and land disturbing activities with structural or impervious surfaces. The definition of “redevelopment” must be consulted to determine whether or not the requirements for new development apply to areas intended for redevelopment. If the definition applies, the steps outlined under “designing new installations” above should be followed.

**Additional Information*****Maintenance Considerations***

The integrity of structural elements that are subject to damage (i.e., screens, covers, and signs) must be maintained by the owner/operator. Maintenance agreements between the local agency and the owner/operator may be required. Some agencies will require maintenance deed restrictions to be recorded of the property title. If required by the local agency, maintenance agreements or deed restrictions must be executed by the owner/operator before improvement plans are approved.

**Other Resources**

A Manual for the Standard Urban Stormwater Mitigation Plan (SUSMP), Los Angeles County Department of Public Works, May 2002.

Model Standard Urban Storm Water Mitigation Plan (SUSMP) for San Diego County, Port of San Diego, and Cities in San Diego County, February 14, 2002.

Model Water Quality Management Plan (WQMP) for County of Orange, Orange County Flood Control District, and the Incorporated Cities of Orange County, Draft February 2003.

Ventura Countywide Technical Guidance Manual for Stormwater Quality Control Measures, July 2002.



## Maintenance Concerns, Objectives, and Goals

- Clogged Soil or Outlet Structures
- Invasive Species
- Vegetation/Landscape Maintenance
- Erosion
- Channelization of Flow
- Aesthetics

## General Description

The bioretention best management practice (BMP) functions as a soil and plant-based filtration device that removes pollutants through a variety of physical, biological, and chemical treatment processes. These facilities normally consist of a grass buffer strip, sand bed, ponding area, organic layer or mulch layer, planting soil, and plants. The runoff's velocity is reduced by passing over or through a sand bed and is subsequently distributed evenly along a ponding area. Exfiltration of the stored water in the bioretention area planting soil into the underlying soils occurs over a period of days.

## Inspection/Maintenance Considerations

Bioretention requires frequent landscaping maintenance, including measures to ensure that the area is functioning properly, as well as maintenance of the landscaping on the practice. In many cases, bioretention areas initially require intense maintenance, but less maintenance is needed over time. In many cases, maintenance tasks can be completed by a landscaping contractor, who may already be hired at the site. In cold climates the soil may freeze, preventing runoff from infiltrating into the planting soil.

## Targeted Constituents

✓ Sediment	■
✓ Nutrients	▲
✓ Trash	■
✓ Metals	■
✓ Bacteria	■
✓ Oil and Grease	■
✓ Organics	■

### Legend (Removal Effectiveness)

- Low
- High
- ▲ Medium



Inspection Activities	Suggested Frequency
<ul style="list-style-type: none"> <li>■ Inspect soil and repair eroded areas.</li> </ul>	Monthly
<ul style="list-style-type: none"> <li>■ Inspect for erosion or damage to vegetation, preferably at the end of the wet season to schedule summer maintenance and before major fall runoff to be sure the strips are ready for winter. However, additional inspection after periods of heavy runoff is desirable.</li> </ul>	Semi-annual inspection
<ul style="list-style-type: none"> <li>■ Inspect to ensure grass is well established. If not, either prepare soil and reseed or replace with alternative species. Install erosion control blanket.</li> </ul>	
<ul style="list-style-type: none"> <li>■ Check for debris and litter, and areas of sediment accumulation.</li> <li>■ Inspect health of trees and shrubs.</li> </ul>	
Maintenance Activities	Suggested Frequency
<ul style="list-style-type: none"> <li>■ Water plants daily for 2 weeks.</li> </ul>	At project completion
<ul style="list-style-type: none"> <li>■ Remove litter and debris.</li> </ul>	Monthly
<ul style="list-style-type: none"> <li>■ Remove sediment.</li> <li>■ Remulch void areas.</li> <li>■ Treat diseased trees and shrubs.</li> <li>■ Mow turf areas.</li> <li>■ Repair erosion at inflow points.</li> <li>■ Repair outflow structures.</li> <li>■ Unclog underdrain.</li> <li>■ Regulate soil pH regulation.</li> </ul>	As needed
<ul style="list-style-type: none"> <li>■ Remove and replace dead and diseased vegetation.</li> </ul>	Semi-annual
<ul style="list-style-type: none"> <li>■ Add mulch.</li> </ul>	Annual
<ul style="list-style-type: none"> <li>■ Replace tree stakes and wires.</li> </ul>	Every 2-3 years, or as needed
<ul style="list-style-type: none"> <li>■ Mulch should be replaced every 2 to 3 years or when bare spots appear. Remulch prior to the wet season.</li> </ul>	

### Additional Information

Landscaping is critical to the function and aesthetic value of bioretention areas. It is preferable to plant the area with native vegetation, or plants that provide habitat value, where possible. Another important design feature is to select species that can withstand the hydrologic regime they will experience. At the bottom of the bioretention facility, plants that tolerate both wet and dry conditions are preferable. At the edges, which will remain primarily dry, upland species will be the most resilient. It is best to select a combination of trees, shrubs, and herbaceous materials.

### References

Metropolitan Council, Urban Small Sites Best Management Practices Manual. Available at: <http://www.metrocouncil.org/environment/Watershed/BMP/manual.htm>

Model Urban Runoff Program: A How-To Guide for Developing Urban Runoff Programs for Small Municipalities. Prepared by City of Monterey, City of Santa Cruz, California Coastal Commission, Monterey Bay National Marine Sanctuary, Association of Monterey Bay Area Governments, Woodward-Clyde, Central Coast Regional Water Quality Control Board. July, 1998, revised February, 2002.

U.S. Environmental Protection Agency, Post-Construction Stormwater Management in New Development & Redevelopment BMP Factsheets. Available at:  
[cfpub.epa.gov/npdes/stormwater/menuofbmps/bmp\\_files.cfm](http://cfpub.epa.gov/npdes/stormwater/menuofbmps/bmp_files.cfm)

Ventura Countywide Stormwater Quality Management Program, Technical Guidance Manual for Stormwater Quality Control Measures. July, 2002.

## General Description

Water quality inlets (WQIs), also commonly called trapping catch basins, oil/grit separators or oil/water separators, consist of one or more chambers that promote sedimentation of coarse materials and separation of free oil (as opposed to emulsified or dissolved oil) from stormwater. Some WQIs also contain screens to help retain larger or floating debris, and many of the newer designs also include a coalescing unit that helps promote oil/water separation.

These devices are appropriate for capturing hydrocarbon spills, but provide very marginal sediment removal and are not very effective for treatment of stormwater runoff. WQIs typically capture only the first portion of runoff for treatment and are generally used for pretreatment before discharging to other best management practices (BMPs).

## Inspection/Maintenance Considerations

High sediment loads can interfere with the ability of the WQI to effectively separate oil and grease from the runoff. During periods of high flow, sediment can be resuspended and released from the WQI into surface waters. Maintenance of WQIs can be easily neglected because they are underground. Establishment of a maintenance schedule is helpful for ensuring proper maintenance occurs. The required maintenance effort will be site-specific due to variations in sediment and hydrocarbon loading. Since WQI residuals contain hydrocarbon by-products, they may require disposal as hazardous waste. Many WQI owners coordinate with waste haulers to collect and dispose of these residuals.

## Maintenance Concerns, Objectives, and Goals

- High Sediment Loads
- Hazardous Waste
- Vector Control

## Targeted Constituents

✓ Sediment	●
✓ Nutrients	●
✓ Trash	▲
✓ Metals	●
✓ Bacteria	●
✓ Oil and Grease	▲
✓ Organics	●

### Legend (Removal Effectiveness)

- Low      ■ High  
▲ Medium



Inspection Activities	Suggested Frequency
<ul style="list-style-type: none"> <li>■ Inspect after every storm event to determine if maintenance is required.</li> </ul>	Monthly during the wet season, or after significant rain events
Maintenance Activities	Suggested Frequency
<ul style="list-style-type: none"> <li>■ Clean out and dispose of accumulated oil, grease, and sediments. Remove accumulated trash and debris. The clean out and disposal techniques should be environmentally acceptable and in accordance with local regulations.</li> </ul>	Annual, before the wet season, or more frequent as needed

### Additional Information

Since WQIs can be relatively deep, they may be designated as confined spaces. Caution should be exercised to comply with confined space entry safety regulations if it is required.

### References

<http://www.co.pierce.wa.us/pc/services/home/environ/water/swm/sppman/bmpt1.htm>

# Isolator<sup>®</sup> Row Plus

## O&M Manual

---



# The Isolator<sup>®</sup> Row Plus

## Introduction

An important component of any Stormwater Pollution Prevention Plan is inspection and maintenance. The StormTech Isolator Row Plus is a technique to inexpensively enhance Total Suspended Solids (TSS) and Total Phosphorus (TP) removal with easy access for inspection and maintenance.

## The Isolator Row Plus

The Isolator Row Plus is a row of StormTech chambers, either SC-160, SC-310, SC-310-3, SC-740, DC-780, MC-3500 or MC-7200 models, that is surrounded with filter fabric and connected to a closely located manhole for easy access. The fabric-wrapped chambers provide for sediment settling and filtration as stormwater rises in the Isolator Row Plus and passes through the filter fabric. The open bottom chambers and perforated sidewalls (SC-310, SC-310-3 and SC-740 models) allow stormwater to flow both vertically and horizontally out of the chambers. Sediments are captured in the Isolator Row Plus protecting the adjacent stone and chambers storage areas from sediment accumulation.

ADS geotextile fabric is placed between the stone and the Isolator Row Plus chambers. The woven geotextile provides a media for stormwater filtration, a durable surface for maintenance, prevents scour of the underlying stone and remains intact during high pressure jetting. A non-woven fabric is placed over the chambers to provide a filter media for flows passing through the chamber's sidewall. The non-woven fabric is not required over the SC-160, DC-780, MC-3500 or MC-7200 models as these chambers do not have perforated side walls.

The Isolator Row Plus is designed to capture the "first flush" runoff and offers the versatility to be sized on a volume basis or a flow-rate basis. An upstream manhole provides access to the Isolator Row Plus and includes a high/low concept such that stormwater flow rates or volumes that exceed the capacity of the Isolator Row Plus bypass through a manifold to the other chambers. This is achieved with an elevated bypass manifold or a high-flow weir. This creates a differential between the Isolator Row Plus row of chambers and the manifold to the rest of the system, thus allowing for settlement time in the Isolator Row Plus. After Stormwater flows through the Isolator Row Plus and into the rest of the chamber system it is either exfiltrated into the soils below or passed at a controlled rate through an outlet manifold and outlet control structure.

The Isolator Row FLAMP<sup>™</sup> (patent pending) is a flared end ramp apparatus attached to the inlet pipe on the inside of the chamber end cap. The FLAMP provides a smooth transition from pipe invert to fabric bottom. It is configured to improve chamber function performance by enhancing outflow of solid debris that would otherwise collect at the chamber's end. It also serves to improve the fluid and solid flow into the access pipe during maintenance and cleaning and to guide cleaning and inspection equipment back into the inlet pipe when complete.

The Isolator Row Plus may be part of a treatment train system. The treatment train design and pretreatment device selection by the design engineer is often driven by regulatory requirements. Whether pretreatment is used or not, StormTech recommend using the Isolator Row Plus to minimize maintenance requirements and maintenance costs.

**Note:** See the StormTech Design Manual for detailed information on designing inlets for a StormTech system, including the Isolator Row Plus.



Looking down the Isolator Row PLUS from the manhole opening, ADS PLUS Fabric is shown between the chamber and stone base.



StormTech Isolator Row PLUS with Overflow Spillway (not to scale)

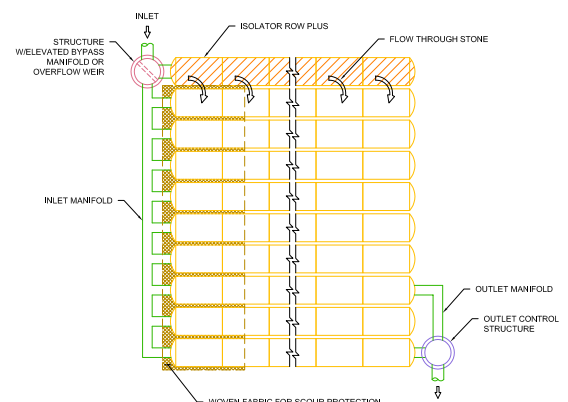

# Isolator Row Plus Inspection/Maintenance

## Inspection

The frequency of inspection and maintenance varies by location. A routine inspection schedule needs to be established for each individual location based upon site specific variables. The type of land use (i.e. industrial, commercial, residential), anticipated pollutant load, percent imperviousness, climate, etc. all play a critical role in determining the actual frequency of inspection and maintenance practices.

At a minimum, StormTech recommends annual inspections. Initially, the Isolator Row Plus should be inspected every 6 months for the first year of operation. For subsequent years, the inspection should be adjusted based upon previous observation of sediment deposition.

The Isolator Row Plus incorporates a combination of standard manhole(s) and strategically located inspection ports (as needed). The inspection ports allow for easy access to the system from the surface, eliminating the need to perform a confined space entry for inspection purposes.

If upon visual inspection it is found that sediment has accumulated, a stadia rod should be inserted to determine the depth of sediment. When the average depth of sediment exceeds 3 inches throughout the length of the Isolator Row Plus, clean-out should be performed.

## Maintenance

The Isolator Row Plus was designed to reduce the cost of periodic maintenance. By "isolating" sediments to just one row, costs are dramatically reduced by eliminating the need to clean out each row of the entire storage bed. If inspection indicates the potential need for maintenance, access is provided

via a manhole(s) located on the end(s) of the row for cleanout. If entry into the manhole is required, please follow local and OSHA rules for a confined space entries.

Maintenance is accomplished with the JetVac process. The JetVac process utilizes a high pressure water nozzle to propel itself down the Isolator Row Plus while scouring and suspending sediments. As the nozzle is retrieved, the captured pollutants are flushed back into the manhole for vacuuming. Most sewer and pipe maintenance companies have vacuum/JetVac combination vehicles. Selection of an appropriate JetVac nozzle will improve maintenance efficiency. Fixed nozzles designed for culverts or large diameter pipe cleaning are preferable. Rear facing jets with an effective spread of at least 45" are best. StormTech recommends a maximum nozzle pressure of 2000 psi be utilized during cleaning. JetVac reels can vary in length. For ease of maintenance, ADS recommends Isolator Row Plus lengths up to 200' (61 m). **The JetVac process shall only be performed on StormTech Isolator Row Plus that have ADS Plus Fabric (as specified by StormTech) over their angular base stone.**

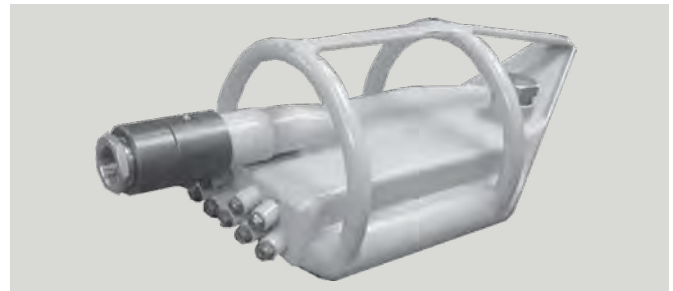

## StormTech Isolator Row PLUS (not to scale)

**Note:** Non-woven fabric is only required over the inlet pipe connection into the end cap for SC-160LP, DC-780, MC-3500 and MC-7200 chamber models and is not required over the entire Isolator Row PLUS.

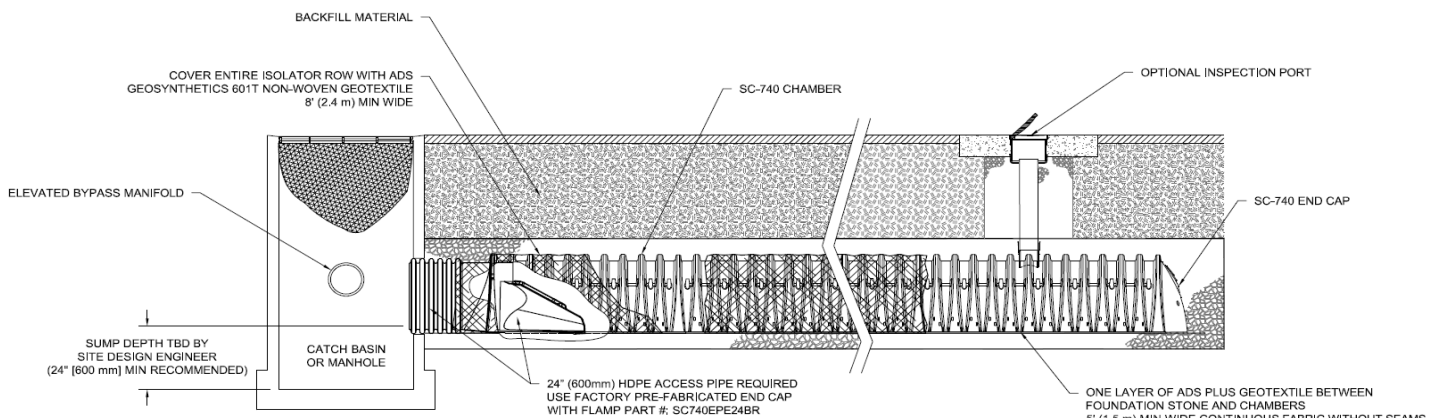

# Isolator Row Plus Step By Step Maintenance Procedures

## Step 1

Inspect Isolator Row Plus for sediment.

- A) Inspection ports (if present)
  - i. Remove lid from floor box frame
  - ii. Remove cap from inspection riser
  - iii. Using a flashlight and stadia rod, measure depth of sediment and record results on maintenance log.
  - iv. If sediment is at or above 3 inch depth, proceed to Step 2. If not, proceed to Step 3.
- B) All Isolator Row Plus
  - i. Remove cover from manhole at upstream end of Isolator Row Plus
  - ii. Using a flashlight, inspect down Isolator Row Plus through outlet pipe
    1. Mirrors on poles or cameras may be used to avoid a confined space entry
    2. Follow OSHA regulations for confined space entry if entering manhole
  - iii. If sediment is at or above the lower row of sidewall holes (approximately 3 inches), proceed to Step 2. If not, proceed to Step 3.

## Step 2

Clean out Isolator Row Plus using the JetVac process.

- A) A fixed floor cleaning nozzle with rear facing nozzle spread of 45 inches or more is preferable
- B) Apply multiple passes of JetVac until backflush water is clean
- C) Vacuum manhole sump as required

## Step 3

Replace all caps, lids and covers, record observations and actions.

## Step 4

Inspect & clean catch basins and manholes upstream of the StormTech system.

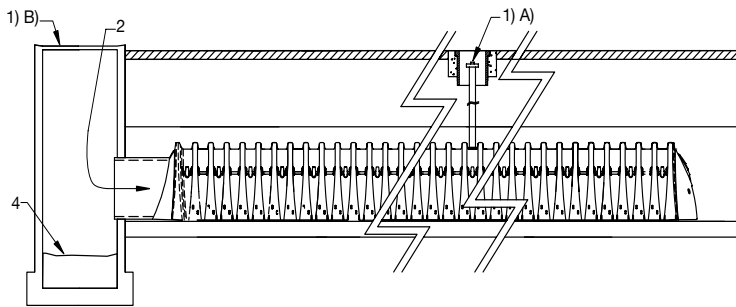

## Sample Maintenance Log

Date	Stadia Rod Readings		Sedi-ment Depth (1)-(2)	Observations/Actions	Inspector
	Fixed point to chamber bottom (1)	Fixed point to top of sediment (2)			
3/15/11	6.3 ft	none		New installation. Fixed point is CI frame at grade	DJM
9/24/11		6.2	0.1 ft	Some grit felt	SM
6/20/13		5.8	0.5 ft	Mucky feel, debris visible in manhole and in Isolator Row PLUS, maintenance due	NV
7/7/13	6.3 ft		0	System jetted and vacuumed	DJM

adspipe.com

800-821-6710